

GOLD CUP[®] P6-7-8 Options Spare Parts Manual

High Pressure Closed and Open Circuit Piston Pumps

HY28-2667-03/GC/US

Effective: March 15, 2013



ENGINEERING YOUR SUCCESS.

Hydraulic Pump and Power Systems Division and Denison Hydraulics

The Hydraulic Pump and Power Systems Division of Parker Hannifin was formed in 2004 when our significant piston pump business was expanded through the acquisition of **Denison Hydraulics**. The addition of **Denison** allowed us to marry the wealth of knowledge that both companies have in the design, manufacture, and application of piston products in both open circuit and closed circuit system applications. Since before WWII, **Denison** products have been chosen for Military test stand applications and for shipboard hydraulic applications being recognized as technology leaders.

The heavy duty **GOLD CUP®** series of pumps in this catalog represent a broadening of our product offering with hydrostatic transmission applications in marine, drilling, and shredding applications, among others. The tried and true design of the **GOLD CUP®** product line incorporates features such as integral servo and replenishing pump, hot oil shuttle, and a unique servo control system; all of which combine to provide a rugged self contained package which can withstand the harshest of conditions and continue to perform with trouble free long life.

The division is a leading worldwide manufacturer of hydraulic components and systems for earthmoving and construction vehicles; for mining equipment; for pulp and paper, chemical and other processing equipment; for ships and ordnance equipment; and for such in-plant machines as machine tools, plastic molding, die casters, and stamping presses.



The product information, specifications, and descriptions contained in this publication have been compiled for the use and convenience of our customers from information furnished by the manufacturer; and we can not, and do not, accept any responsibility for the accuracy or correctness of any description, calculation, specification, or information contained herein. No such description, calculation, specification, or information regarding the products being sold has been made part of the basis of the bargain, nor has same created or amounted to an express warranty that the products would conform thereto. We are selling the goods and merchandise illustrated and described on this publication on an "as is" basis, and disclaim any implied warranty, including any warranty of merchantability or warranty of fitness for any particular purpose whatsoever, with respect to the goods and merchandise sold. All manufacturer warranties shall be passed on to our customers, but we shall not be responsible for special, indirect, incidental, or consequential damages resulting from the use of any of the products or information contained or described on this publication. Further, we reserve the right to revise or otherwise make product improvements at any time without notification.



WARNING - USER RESPONSIBILITY

FAILURE OR IMPROPER SELECTION OR IMPROPER USE OF THE PRODUCTS DESCRIBED HEREIN OR RELATED ITEMS CAN CAUSE DEATH, PERSONAL INJURY AND PROPERTY DAMAGE.

This document and other information from Parker-Hannifin Corporation, its subsidiaries and authorized distributors provide product or system options for further investigation by users having technical expertise.

The user, through its own analysis and testing, is solely responsible for making the final selection of the system and components and assuring that all performance, endurance, maintenance, safety and warning requirements of the application are met. The user must analyze all aspects of the application, follow applicable industry standards, and follow the information concerning the product in the current product catalog and in any other materials provided from Parker or its subsidiaries or authorized distributors.

To the extent that Parker or its subsidiaries or authorized distributors provide component or system options based upon data or specifications provided by the user, the user is responsible for determining that such data and specifications are suitable and sufficient for all applications and reasonably foreseeable uses of the components or systems.

OFFER OF SALE

The items described in this document are hereby offered for sale by Parker-Hannifin Corporation, its subsidiaries or its authorized distributor. This offer and its acceptance are governed by the provisions stated in the detailed "Offer of Sale" elsewhere in this document.

Contents

Design Series—A, C

Pump Ordering Code2
P6-7-8 Sectional Views4
 Section View - A - Input Shaft & Retainer Assembly.....6
 Section View - A - Kits.8
 Section View - B - Housing, Mtg. Flange, & Stem Assembly 10
 Section View - C - Cam & Cradle Assembly 12
 Section View - D - Rotating Group Assembly..... 14
 Section View - E - Pump Type - P & D - Port Block Assembly..... 16
 Section View - E - Pump Type - V - Port Block Assembly. 18
 Section View - E - Pump Type - S & X - Port Block Assembly20
 Section View - E - Pump Type - R - Port Block Assembly.....22
 Section View - E - Pump Type - L - Port Block Assembly24
 Section View - F - Valve Block Assembly.....26
Offer of Sale29

Notes:

1. Parts list and associated drawings shown in this bulletin are for standard model pumps only. All documentation for special “M2” modification pump model numbers must be verified with an HPS Factory Representative prior to ordering parts for such products.
2. * Indicates Special Instructions or Considerations.
3. ** Indicates Common Parts.
4. N/A Indicates Not Available or Not Applicable.
5. All documentation represented in this bulletin is for standard production models only, (as follows):
 - 5.1. P6 = Design Level “C” Model Pump
 - 5.2. P7 = Design Level “A” Model Pump
 - 5.3. P8 = Design Level “A” Model Pump
6. See ordering code for configuration options.
7. All orientation references are described when viewing pump from main drive shaft with valve block up.
8. Assembly part numbers with - 0 suffixes, indicate Buna N (Nitrile) seal compound. For Ethylene Propylene, (EPR), compound, use - 4 suffix. For Fluorocarbon compound use - 5 suffixes.
9. Detail part numbers for O-rings with 671 / 691 prefix, indicate Buna N (Nitrile) seal compound. For Ethylene Propylene, (EPR), compound, use 674 / 694 prefix. For Fluorocarbon compound use 675 / 695 prefix.
10. Drawings with items marked with double balloons “◎”, indicate assemblies.



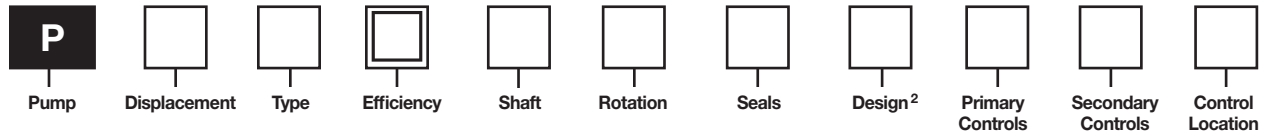

Code	Displacement
6	6.00 in ³ /rev (98 cc/rev)
7	7.25 in ³ /rev (119 cc/rev)
8	8.00 in ³ /rev (131 cc/rev)
11	11.0 in ³ /rev (180 cc/rev)
14	14.0 in ³ /rev (229 cc/rev)
24	24.6 in ³ /rev (403 cc/rev)
30	30.6 in ³ /rev (501 cc/rev)

Code	Type
F	Fixed Displacement, Open/Closed Circuit
M	Fixed Displacement with High Torque Thru-Drive, Open/Closed Circuit
P	Variable Displacement, Closed Circuit
X	Variable Displacement with Medium Torque Thru-Drive, Closed Circuit
S	Variable Displacement with Medium Torque Thru-Drive & Shuttle Package, Closed Circuit
R	Variable Displacement with High Torque Thru-Drive, Closed Circuit
L	Variable Displacement with High Torque Thru-Drive & Shuttle Package, Closed Circuit
V	Variable Displacement, Open Circuit (P6, 7, 8, 11 & 14 only)
D	Variable Displacement, Open & Closed Circuit (P6, 7 & 8 only)

Code	Efficiency
H	High Efficiency (P24 only)
Omit	Standard Efficiency

Code	Shaft
2	Keyed SAE – Mechanical Shaft Seal (Single Lip Seal on P6, 7, 8F/M)
3	Splined SAE – Mechanical Shaft Seal (Single Lip Seal on P6, 7, 8F/M)
4	Keyed SAE-D (Mounting & Shaft) – Mechanical Shaft Seal (P6, 7 & 8 only, Single Lip Seal on Fixed Displacement Pumps)
-5	Splined SAE-D (Mounting & Shaft) – Mechanical Shaft Seal (P6, 7 & 8 only, Single Lip Seal on Fixed Displacement Pumps)
7	Keyed SAE – Double Lip Shaft Seal
8	Splined SAE – Double Lip Shaft Seal
9	Keyed (long) SAE – Double Lip Shaft Seal
10	Keyed (long) SAE – Mechanical Shaft Seal

Code	Rotation
R	Clockwise
L	Counterclockwise

Code	Seals
1	Nitrile (Buna-N)
4	EPR ^{1,3}
5	Fluorocarbon

Code	Primary Controls
Omit	None (Fixed Displacement only)
10	Screw Adjustment (Spring Offset to Maximum Displacement)
2A	Cylinder Control w/Adjustable Maximum Volume Stops
2H	Cylinder Control – 3-Position (Spring Control with Zero Adjustment)
2M	Cylinder Control – 2-Position Electrohydraulic w/Adjustable Maximum Volume Stop (Spring Offset to Maximum Displacement) ¹
2N	Cylinder Control – 3-Position (Spring Centered) Electrohydraulic ¹
40	Rotary Servo – Spring Centered
4A	Rotary Servo – Spring Centered w/Adjustable Maximum Volume Stops
4B	Rotary Servo – Spring Centered w/Automatic Brake Control
4C	Rotary Servo – Spring centered w/Adjustable Maximum Volume Stops & Automatic Brake Control
5A	Electrohydraulic Stroker w/Adjustable Maximum Volume Stops ¹
5C	Electrohydraulic Stroker w/Adjustable Maximum Volume Stops & Automatic Brake Control ¹
7D	High IQ with 10 GPM Servo Valve & Volume Indicator ¹
7F	High IQ with 10 GPM Servo Valve & 4A (Rotary Servo) Control ¹
7J	High IQ with DF+ Valve & Volume Indicator ¹
7K	High IQ with DF+ Valve & 4A (Rotary Servo) Control ¹
8A	Hydraulic Stroker w/Adjustable Maximum Volume Stops
8C	Hydraulic Stroker w/Adjustable Maximum Volume Stops & Automatic Brake Control
9A	Electrohydraulic Stroker w/Adjustable Maximum Volume Stops ¹
9C	Electrohydraulic Stroker w/Adjustable Maximum Volume Stops & Automatic Brake Control ¹
9D	Electro-hydraulic stroker w/adjustable maximum volume stops

Code	Secondary Controls
Omit	None (Fixed Displacement only)
2	Volume Indicator
4	Torque Limiter & Volume Indicator
6	Cam Position Feedback Potentiometer ¹
7	Cam Position Feedback RVDVT (AC) ¹
8	Cam Position Feedback R VDT (DC) ¹

Code	Control Location
Omit	None (Fixed Displacement only)
A	Primary Control on Port A Side
B	Primary Control on Port B Side

- 1 Not ATEX approved.
- 2 Assigned by manufacturer
- 3 Not available when using "5A" or "5C" primary controls. Pump will be unpainted unless otherwise specified.

= Omit if not required

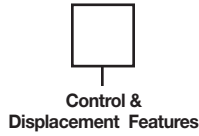

Control	Code	Control & Displacement Features
2M* & 2N*	00	CETOP3, NG6 Valve, 110AC/60Hz with Hirschmann Connector ¹
	01	CETOP3, NG6 Valve, 12VDC with Hirschmann Connector ¹
	02	CETOP3, NG6 Valve, 240VAC/50Hz with Hirschmann Connector ¹
	03	CETOP3, NG6 Valve, 110VAC/60Hz, Wiring Box ¹
	04	CETOP3, NG6 Valve, 12VDC, Wiring Box ¹
	05	CETOP3 (D03, NG6) Interface, No Valve ¹
	06	CETOP3, NG6 Valve, 24VDC with Hirschmann Connector ¹
	07	CETOP3, NG6 Valve, 110VAC/50Hz with Hirschmann Connector ¹
5**	00	With Deadband ¹
	01	Without Deadband ¹
7**	00	Without Manual Override Shutoff ¹
	01	With Manual Override Shutoff ¹ (required for F & K primary options)
8**	00	75-350 PSI (5-24 Bar)
	01	75-435 PSI (5-30 Bar)
	02	100-375 PSI (7-26 Bar)
	03	150-400 PSI (10-28 Bar)
	04	75-250 PSI (5-17 Bar)
9**	00	24VDC
	01	12VDC
All Other	00	None ¹
Pump	Code	Reduced Displacement
P**F & P**M	00	Standard Cam (19°)
	10	P6 with 17° Cam – 5.3 in ³ /rev (87cc/rev) P7 with 17° Cam – 6.4 in ³ /rev (105 cc/rev) P8 with 17° Cam – 7.1 in ³ /rev (116 cc/rev) P11 with 17° Cam – 9.7 in ³ /rev (160 cc/rev) P14 with 17° Cam – 12.5 in ³ /rev (205 cc/rev) P24 with 17° Cam – 22.0 in ³ /rev (360 cc/rev) P30 with 17° Cam – 27.2 in ³ /rev (446 cc/rev)
	20	P6 with 15° Cam – 4.6 in ³ /rev (76 cc/rev) P7 with 15° Cam – 5.6 in ³ /rev (92 cc/rev) P8 with 15° Cam – 6.2 in ³ /rev (102 cc/rev) P11 with 15° Cam – 8.5 in ³ /rev (140 cc/rev) P14 with 15° Cam – 10.9 in ³ /rev (179 cc/rev)
	30	P6 with 13° Cam – 4.0 in ³ /rev (66 cc/rev) P7 with 13° Cam – 4.8 in ³ /rev (79 cc/rev) P8 with 13° Cam – 5.3 in ³ /rev (88 cc/rev)

Code	Internal Pump
0	1.07 in ³ /rev (17.5 cc/rev) – P6, 7, 8P/S/X/N/D & P11, 14V only** 2.14 in ³ /rev (35 cc/rev) – P11, 14P/S/X only** 2.81 in ³ /rev (46 cc/rev) – P24, 30P/S/X only (standard)**
1	1.61 in ³ /rev (26.4 cc/rev) – P24, 30P/S/X only (auxiliary external replenishing flow required)
2	1.05 in ³ /rev (17.2 cc/rev) – P24, 30P/S/X only (auxiliary external replenishing flow required)
3	3.56 in ³ /rev (58.3 cc/rev) – P24, 30P/S/X only
4	4.84 in ³ /rev (79.3 cc/rev) – P24, 30P/S/X only
5	5.42 in ³ /rev (88.8 cc/rev) – P24, 30P/S/X only
6	6.10 in ³ /rev (100.0 cc/rev) – P24, 30P/S/X only
X	No Internal Pump (standard on P*R/L/F/M)

** Omit code if no external drive is required.

Code	External Drive
Omit	None ¹
M	Blanking plate – for P6, 7, 8, 11, 14S/X only
A	SAE-A (SAE 82-2) – P6, 7, 8, 11, 14S/X/R/L/M only
B	SAE-B (SAE 101-2) – P6, 7, 8, 11, 14, 24, 30S/X/R/L/M SAE-B (SAE 101-4) – P11, 14, 24, 30R/L/M
C	SAE-C (SAE 127-2) – P6, 7, 8, 11, 14, 24, 30R/L/M & P24, 30S/X SAE-C (SAE 127-4) – P11, 14, 24, 30R/L/M
D	SAE-D (SAE 152-4) – P11, 14, 24, 30R/L/M only
E	SAE-E (SAE 165-4) – P11, 14, 24, 30R/L/M only
F	SAE-F (SAE 177-4) – P24, 30R/L/M only

Code	External Mounting
Omit	No External Drive Required
0	No External Pump Mounted
1	External Pump Mounted (must be separately specified) – Requires Special Modification “-M2” ¹
2	ATEX Externally Mounted Pump

Code	Special Modifications
Omit	None
NP	No Paint ¹
EX	ATEX APPROVED PUMP (May contain additional modifications. Contact tech support.)
M2	Other Special Modification (example: bronze caged barrel bearing for low viscosity fluids, tandem pumps, etc.) ¹

= Omit if not required



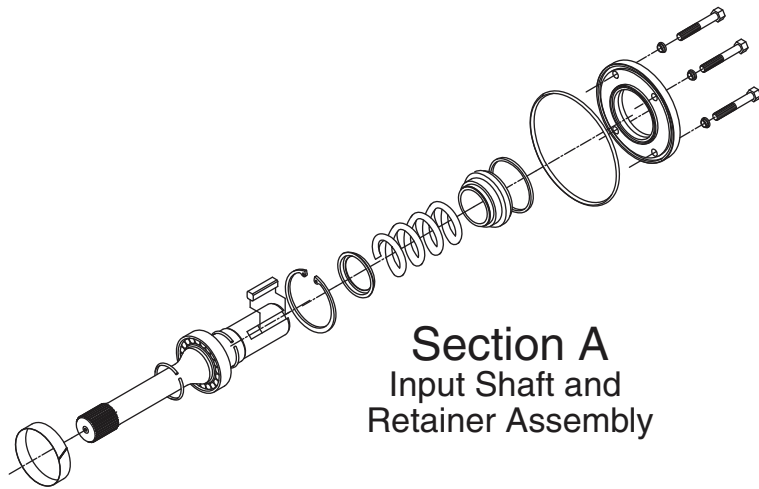

Section A
Input Shaft and
Retainer Assembly

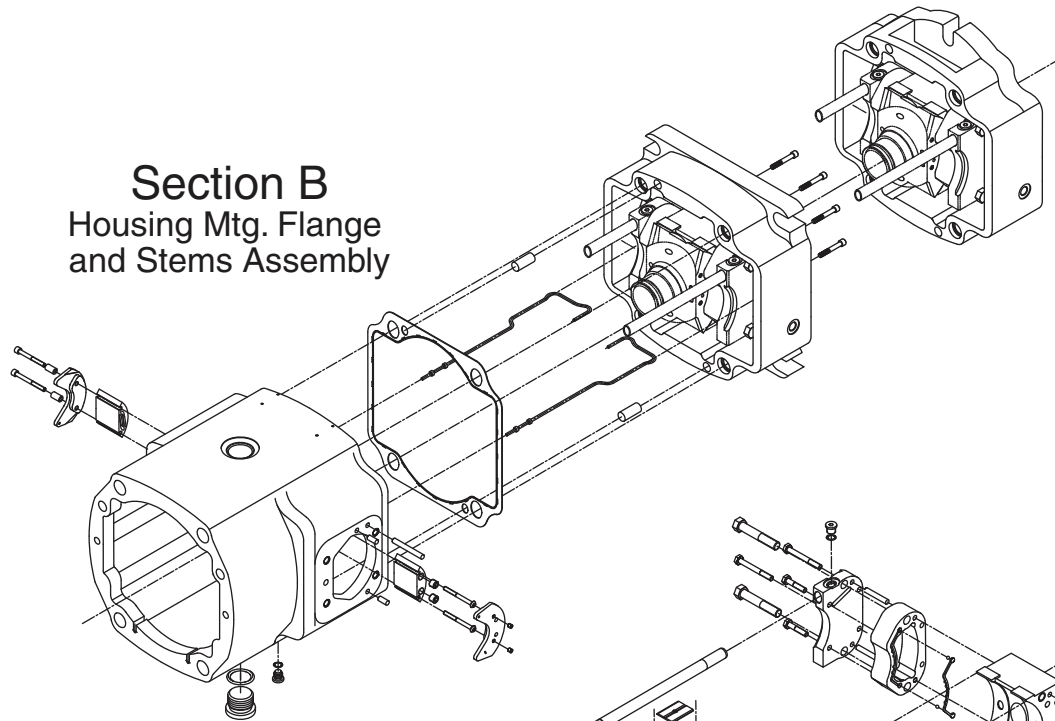

Section B
Housing Mtg. Flange
and Stems Assembly

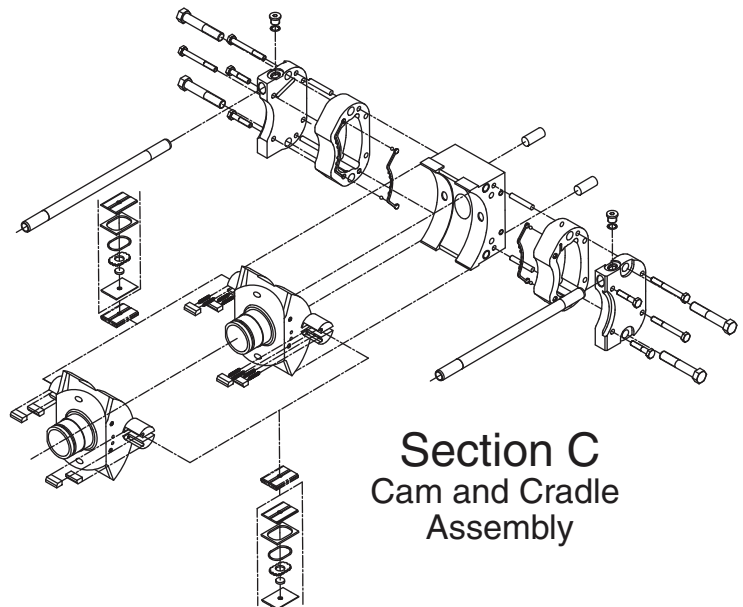

Section C
Cam and Cradle
Assembly

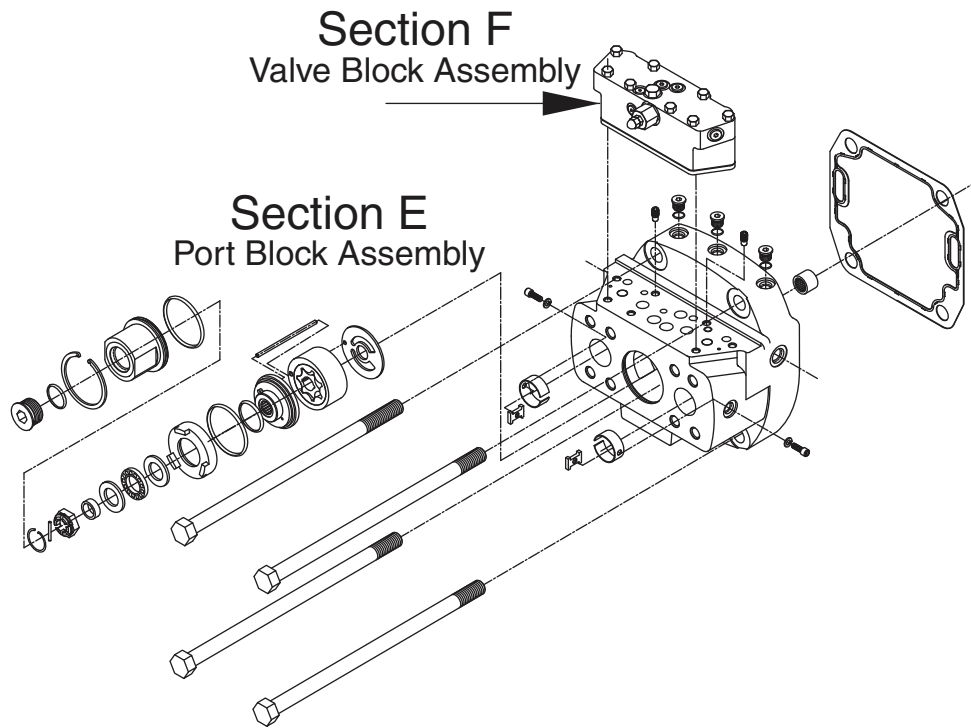
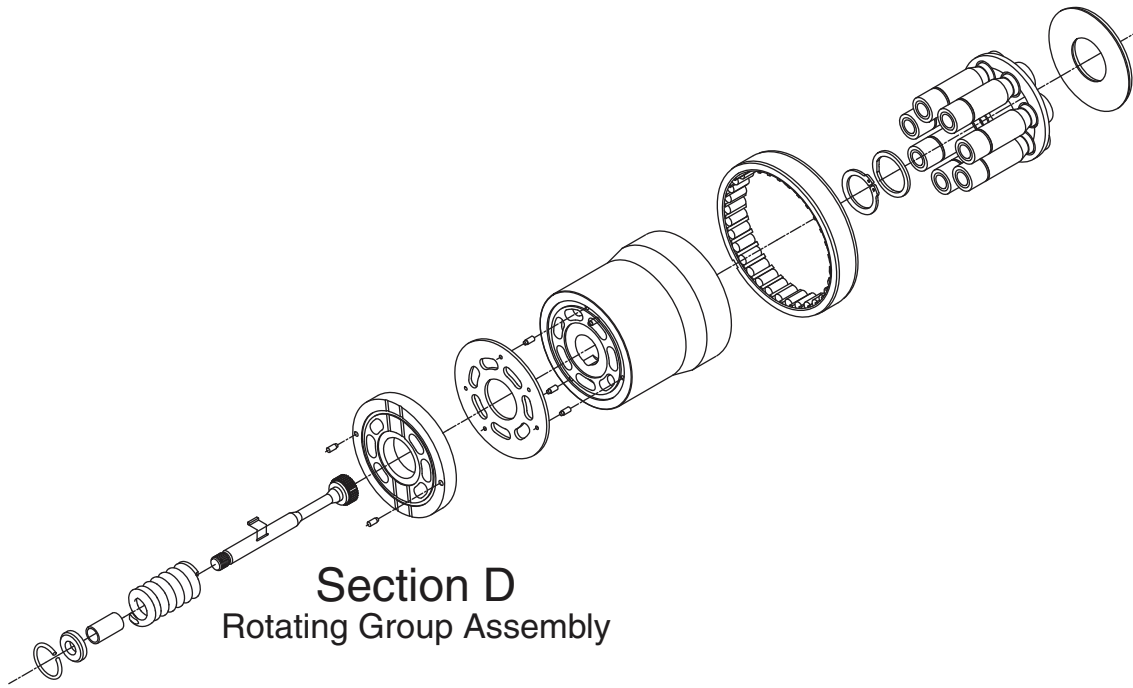

Pump Type P / D / S / V / X

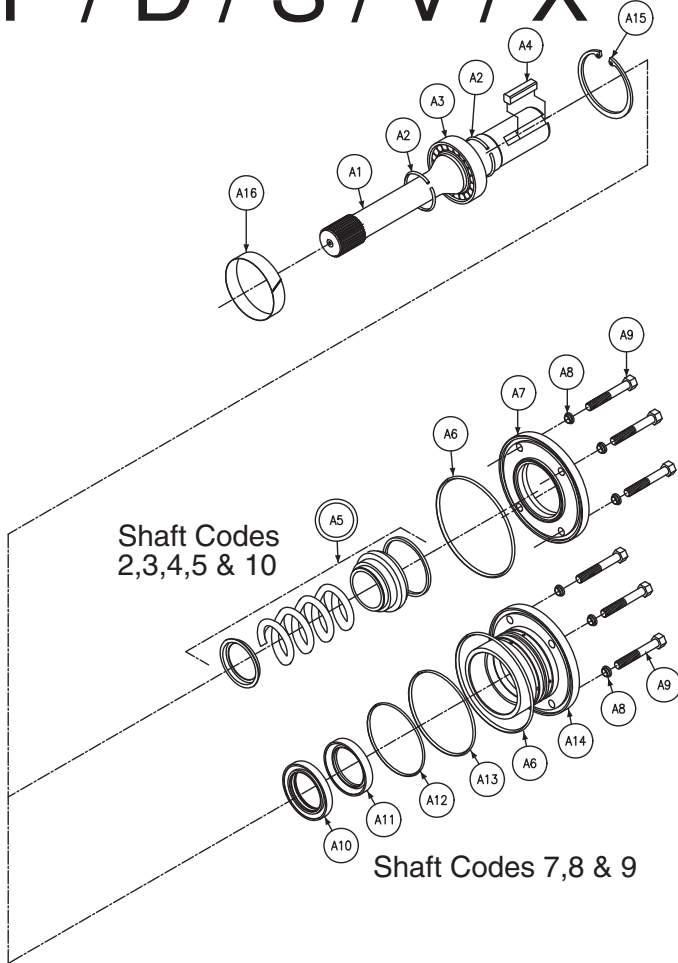

Pump Type R / L

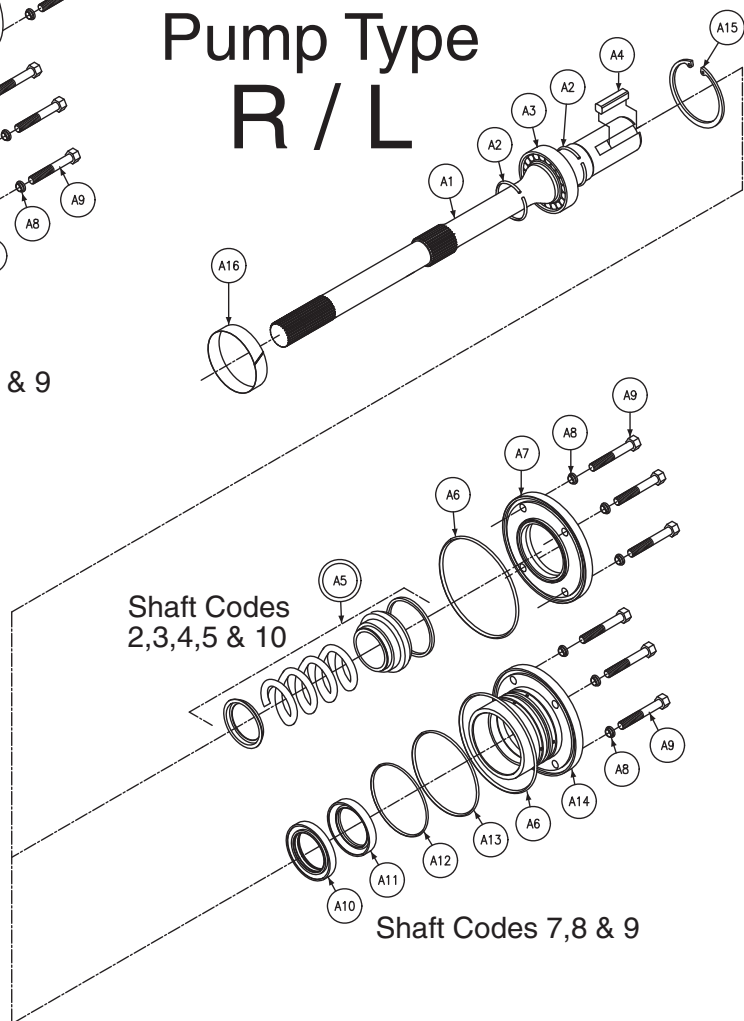

Section A						
P6/7/8 Input shaft and retainer						
Balloon #	Pump Type	Shaft Code	Seal Code	Item #	Description	Qty
A1	P6/7/8 P/D/N/X/S	2	**	033-70579-0	Shaft, Keyed	1
	P6/7/8 P/D/N/X/S	3	**	033-70567-0	Shaft, Splined	
	P6/7/8 P/D/N/X/S	4	**	033-92283-0	Shaft, Keyed	
	P6/7/8 P/D/N/X/S	5	**	033-92282-0	Shaft, Splined	
	P6/7/8 P/D/N/X/S	7	**	033-92959-0	Shaft, Keyed	
	P6/7/8 P/D/N/X/S	8	**	033-92943-0	Shaft, Splined	
	P6/7/8 P/D/N/X/S	9	**	033-93605-0	Shaft, Keyed	
	P6/7/8 P/D/N/X/S	10	**	033-93606-0	Shaft, Keyed	
	P6/7/8 R/L	2	**	033-57862-0	Shaft, Keyed	
	P6/7/8 R/L	3	**	033-57819-0	Shaft, Splined	
	P6/7/8 R/L	4	**	033-93453-0	Shaft, Keyed	
	P6/7/8 R/L	5	**	033-93418-0	Shaft, Splined	
	P6/7/8 R/L	7	**	033-93318-0	Shaft, Keyed	
	P6/7/8 R/L	8	**	033-94244-0	Shaft, Splined	
P6/7/8 R/L	9	**	033-93611-0	Shaft, Keyed		
P6/7/8 R/L	10	**	033-93612-0	Shaft, Keyed		
A2	P6/7/8 P/D/N/X/S/R/L	2/3/7/8/9/10	**	033-70817-0	Retaining ring	2
	P6/7/8 P/D/N/X/S/R/L	4/5	**	033-70817-0	Retaining ring	1
A3	P6/7/8 P/D/N/X/S/R/L	2/3/7/8/9/10	**	230-82140-0	Shaft Bearing	1
	P6/7/8 P/D/N/X/S/R/L	4/5	**	230-00207-0	Shaft Bearing	1
A4	P6/7/8 P/D/N/X/S/R/L	2/7	**	033-71348-0	Key	1
	P6/7/8 P/D/N/X/S/R/L	4	**	031-29899-0		
	P6/7/8 P/D/N/X/S/R/L	9/10	**	033-93617-0		
A5	P6/7/8 P/D/N/X/S/R/L	2/3/10	1	623-00006-0	Shaft Seal	1
	P6/7/8 P/D/N/X/S/R/L	2/3/10	4	623-00006-4		
	P6/7/8 P/D/N/X/S/R/L	2/3/10	5	623-00006-5		
	P6/7/8 P/D/N/X/S/R/L	4/5	1	623-00016-0		
	P6/7/8 P/D/N/X/S/R/L	4/5	4	623-00016-4		
A6	P6/7/8 P/D/N/X/S/R/L	4/5	5	623-00016-5	Gasket O-ring	1
	P6/7/8 P/D/N/X/S/R/L	2/3/7/8/9/10	1	671-00043-0		
	P6/7/8 P/D/N/X/S/R/L	2/3/7/8/9/10	4	674-00043-0		
	P6/7/8 P/D/N/X/S/R/L	2/3/7/8/9/10	5	675-00043-0		
	P6/7/8 P/D/N/X/S/R/L	4/5	1	671-00249-0		
	P6/7/8 P/D/N/X/S/R/L	4/5	4	674-00249-0		
A7	P6/7/8 P/D/N/X/S/R/L	4/5	5	675-00249-0	Seal Retainer	1
	P6/7/8 P/D/N/X/S/R/L	2/3/10	**	033-57892-0		
	P6/7/8 P/D/N/X/S/R/L	4/5	**	033-92286-0		
A8	P6/7/8 P/D/N/X/S/R/L	2/3/7/8/9/10	**	631-45003-0	Nyltite Gasket	4
	P6/7/8 P/D/N/X/S/R/L	4/5	**	631-45007-0		
A9	P6/7/8 P/D/N/X/S/R/L	2/3/7/8/9/10	**	306-40144-0	Hex Hd Cap Screw	4
	P6/7/8 P/D/N/X/S/R/L	4/5	**	306-40016-0		
A10	P6/7/8 P/D/N/X/S/R/L	7/8/9	1	620-82066-0	Inner Seal	1
	P6/7/8 P/D/N/X/S/R/L	7/8/9	4	not available		
	P6/7/8 P/D/N/X/S/R/L	7/8/9	5	not available		
A11	P6/7/8 P/D/N/X/S/R/L	7/8/9	1	620-82114-0	Outer Seal	1
	P6/7/8 P/D/N/X/S/R/L	7/8/9	4	not available		
	P6/7/8 P/D/N/X/S/R/L	7/8/9	5	not available		
A12	P6/7/8 P/D/N/X/S/R/L	7/8/9	1	671-00036-0	Gasket O-ring	1
	P6/7/8 P/D/N/X/S/R/L	7/8/9	4	674-00036-0		
	P6/7/8 P/D/N/X/S/R/L	7/8/9	5	675-00036-0		
A13	P6/7/8 P/D/N/X/S/R/L	7/8/9	1	671-00037-0	Gasket O-ring	1
	P6/7/8 P/D/N/X/S/R/L	7/8/9	4	674-00037-0		
	P6/7/8 P/D/N/X/S/R/L	7/8/9	5	675-00037-0		
A14	P6/7/8 P/D/N/X/S/R/L	7/8/9	**	033-92465-0	Seal Retainer	1
A15	P6/7/8 P/D/N/X/S/R/L	2/3/7/8/9/10	**	033-53901-0	Retaining Ring	select fit 1 only
	P6/7/8 P/D/N/X/S/R/L	2/3/7/8/9/10	**	033-53902-0		
	P6/7/8 P/D/N/X/S/R/L	2/3/7/8/9/10	**	033-53903-0		
	P6/7/8 P/D/N/X/S/R/L	4/5	**	356-65139-0		
A16	P6/7/8 P/D/N/X/S	2/3/10	**	033-53948-0	Shim, .008"	select fit 1 only
	P6/7/8 P/D/N/X/S	2/3/10	**	033-53949-0		



Seal Kits Contain All Seals for the Following:			
1. Main Pump			
2. Valve Block			
3. Input/Output Controls			
4. Shaft Seal			
Shaft Code	Pump Type	Seal Code	Part Number
2/3/10	P6/7/8 P/D/V	1	S23-17026-0
2/3/10	P6/7/8 P/D/V	4	S23-17026-4
2/3/10	P6/7/8 P/D/V	5	S23-17026-5
4/5	P6/7/8 P/D/V	1	S23-17027-0
4/5	P6/7/8 P/D/V	4	S23-17027-4
4/5	P6/7/8 P/D/V	5	S23-17027-5
7/8/9	P6/7/8 P/D/V	1	S23-17028-0
7/8/9	P6/7/8 P/D/V	4	S23-17028-4
7/8/9	P6/7/8 P/D/V	5	S23-17028-5
2/3/10	P6/7/8 S/X/R/L	1	S23-17029-0
2/3/10	P6/7/8 S/X/R/L	4	S23-17029-4
2/3/10	P6/7/8 S/X/R/L	5	S23-17029-5
4/5	P6/7/8 S/X/R/L	1	S23-17030-0
4/5	P6/7/8 S/X/R/L	4	S23-17030-4
4/5	P6/7/8 S/X/R/L	5	S23-17030-5
7/8/9	P6/7/8 S/X/R/L	1	S23-17031-0
7/8/9	P6/7/8 S/X/R/L	4	S23-17031-4
7/8/9	P6/7/8 S/X/R/L	5	S23-17031-5

Shaft Assemblies		
Composed of Items:		
A1, A2, A3, and A4		
Shaft Code	Pump Type	Part Number
2	P6/7/8 P/D/V/X/S	S13-41806-0
3	P6/7/8 P/D/V/X/S	S13-41805-0
4	P6/7/8 P/D/V/X/S	S23-15832-0
5	P6/7/8 P/D/V/X/S	S23-15831-0
7	P6/7/8 P/D/V/X/S	S23-16539-0
8	P6/7/8 P/D/V/X/S	S23-16514-0
9	P6/7/8 P/D/V/X/S	S23-17486-0
10	P6/7/8 P/D/V/X/S	S23-17487-0
2	P6/7/8 R/L	S23-12093-0
3	P6/7/8 R/L	S23-12044-0
4	P6/7/8 R/L	S23-17222-0
5	P6/7/8 R/L	S23-17167-0
7	P6/7/8 R/L	S23-16944-0
8	P6/7/8 R/L	S23-18302-0
9	P6/7/8 R/L	S23-17492-0
10	P6/7/8 R/L	S23-17493-0

Pump Type P / D / V / X / S / R / L

See Section C for Detail

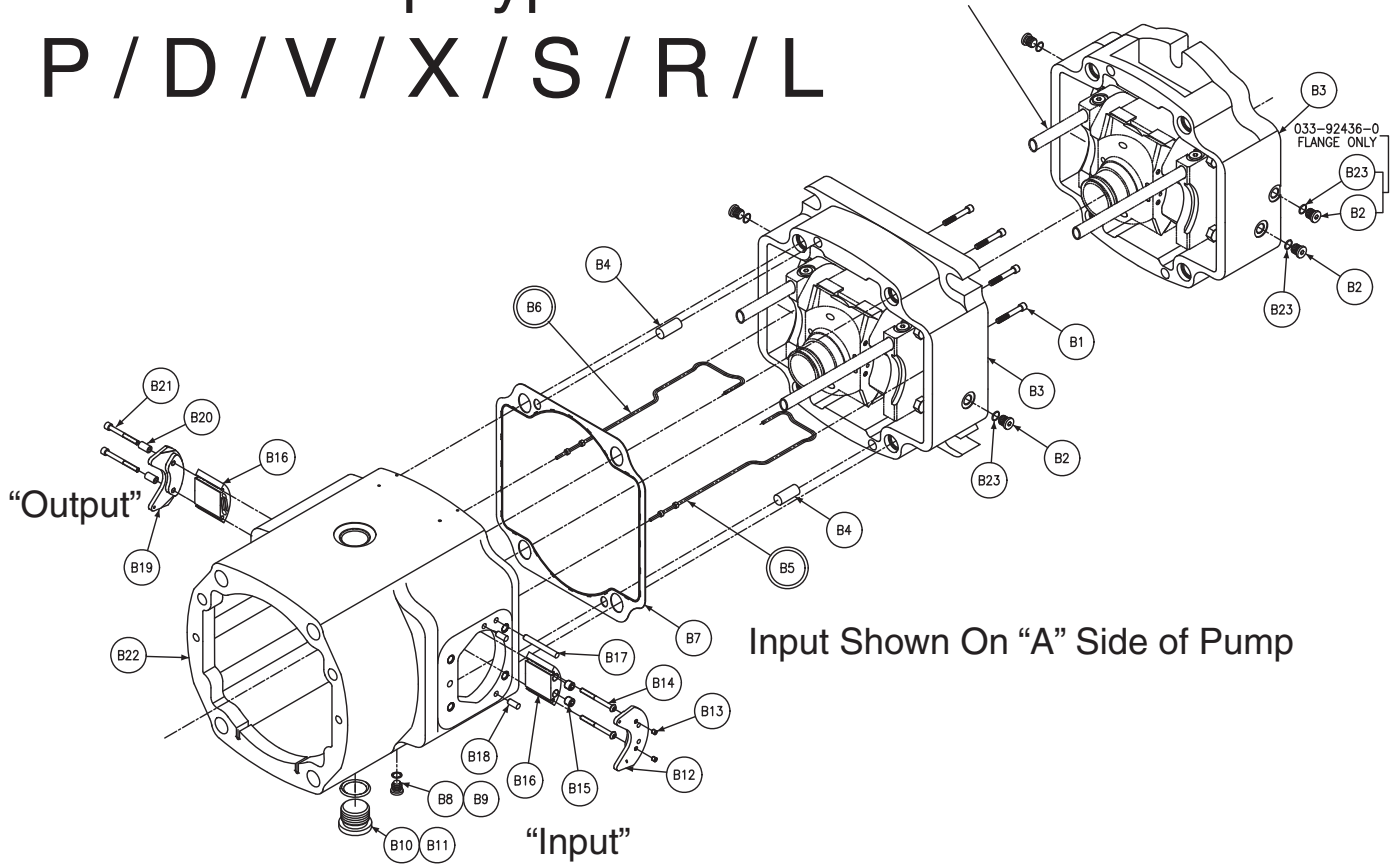

Section B						
P6/7/8 P/D/N/X/S/R/L Housing and stems						
Balloon #	Pump Type	Shaft Code	Seal Code	Item #	Description	Qty
B1	P6/7/8 P/D/N/X/S/R/L	4/5	**	358-12200-0	Screw Socket Head Cap	4
B2	P6/7/8 P/D/N/X/S/R/L	2/3/10	**	488-35001-0	Hex Socket Plug	2
	P6/7/8 P/D/N/X/S/R/L	4/5	**			2
	P6/7/8 P/D/N/X/S/R/L	7/8/9	**			3
B3	P6/7/8 P/D/N/X/S/R/L	2/3/10	**	033-70604-0	Mounting Flange	1
	P6/7/8 P/D/N/X/S/R/L	4/5	**	033-92280-0		
	P6/7/8 P/D/N/X/S/R/L	7/8/9	**	033-92436-0		
B4	P6/7/8 P/D/N/X/S/R/L	**	**	324-22412-0	Dowel Pin	4
B5	P6/7/8 P/D/N/X/S/R/L	**	**	S13-42403-0	Left Feed Tube	1
B6	P6/7/8 P/D/N/X/S/R/L	**	**	S13-42402-0	Right Feed Tube	1
B7	P6/7/8 P/D/N/X/S/R/L	**	**	033-91067-0	Gasket Housing / Mtg Flange	1
B8	P6/7/8 P/D/N/X/S/R/L	**	1	691-00908-0	Gasket, O-ring	1
	P6/7/8 P/D/N/X/S/R/L	**	4	694-00908-0		
	P6/7/8 P/D/N/X/S/R/L	**	5	695-00908-0		
B9	P6/7/8 P/D/N/X/S/R/L	**	**	033-91106-0	Barrel Bearing Retainer	1
B10	P6/7/8 P/D/N/X/S/R/L	**	**	488-35014-0	Plug Hex Socket	2
B11	P6/7/8 P/D/N/X/S/R/L	**	1	691-00912-0	Gasket, O-ring	2
	P6/7/8 P/D/N/X/S/R/L	**	4	694-00912-0		
	P6/7/8 P/D/N/X/S/R/L	**	5	695-00912-0		
B12	P6/7/8 P/D/N/X/S/R/L	**	**	033-53874-0	Servo Input Plate	1
B13	P6/7/8 P/D/N/X/S/R/L	**	**	312-09032-0	Screw	2
B14	P6/7/8 P/D/N/X/S/R/L	**	**	353-25041-0	Button Head Screw	2
B15	P6/7/8 P/D/N/X/S/R/L	**	**	033-70819-0	3/8-24 UNF X 3/8 LG Screw with 1/16" dia Orifice	2
	P6/7/8 V	**	**			1
B16	P6/7/8 P/D/N/X/S/R/L	**	**	033-71312-0	Servo Stem	2
B17	P6/7/8 P/D/N/X/S/R/L	**	**	325-16280-0	Spring Pin	2
B18	P6/7/8 P/D/N/X/S/R/L	**	**	324-21608-0	Dowel Pin	4
B19	P6/7/8 P/D/N/X/S/R/L	**	**	033-70546-0	Balance Plate	1
B20	P6/7/8 P/D/N/X/S/R/L	**	**	033-71247-0	Spacer	2
B21	P6/7/8 P/D/N/X/S/R/L	**	**	358-10300-0	Socket Head Cap Screw	2
B22	P6/7/8 P/D/N/X/S/R/L	**	**	033-91108-0	Housing	1
B23	P6/7/8 P/D/N/X/S/R/L	2/3/10	**	691-00904-0	Gasket, O-ring	2
	P6/7/8 P/D/N/X/S/R/L	4/5	**	694-00904-0		2
	P6/7/8 P/D/N/X/S/R/L	7/8/9	**	695-00904-0		3

Stem Kits	
Input Stem Kits Include the Following:	
B12, B13, B14, B15 and B16	
Output Stem Kits Include the Following:	
B16, B19, B20 and B21	
	Part Number
P6/7/8 Input Stem Kit	S23-12681-0
P6/7/8 Output Stem Kit	S23-03383-0



Pump Type P / D / V / X / S / L / R

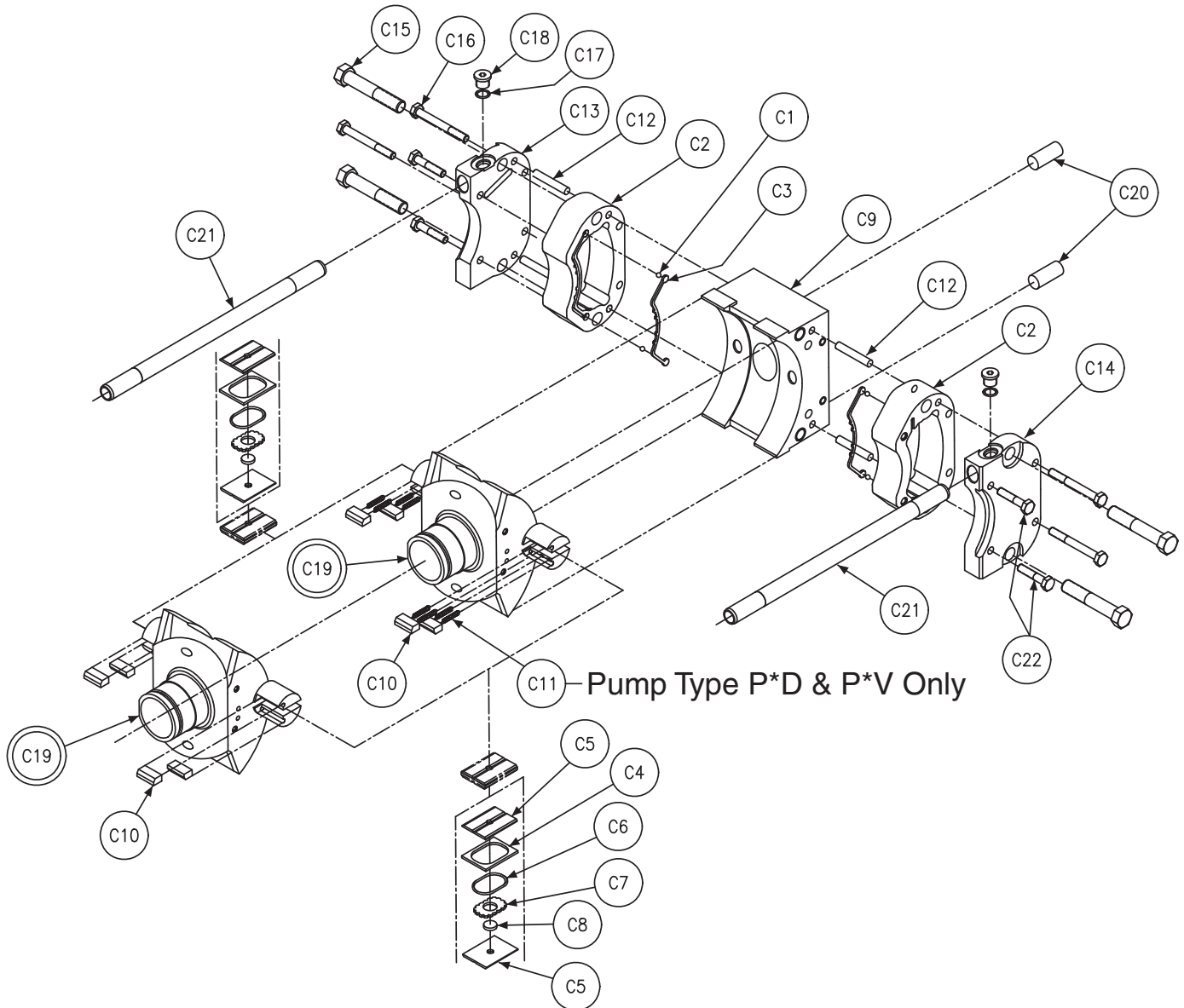

Section C							
P6/7/8 Cam and Cradle Assembly							
Balloon #	Pump Type	Shaft Code	Rotation	Seal Code	Item #	Description	Qty
C1	P/D/N/X/S/L/R	**	**	**	201-06001-0	Check Ball	4
C2	P/D/N/X/S/L/R	**	**	**	033-72266-0	Vane Chamber	2
C3	P/D/N/X/S/L/R	**	**	1	606-25036-0	Molded Seal	2
	P/D/N/X/S/L/R	**	**	4	606-25036-4		
	P/D/N/X/S/L/R	**	**	5	606-25036-5		
C4	P/D/N/X/S/L/R	**	**	**	033-70501-0	Vane Seal	2
C5	P/D/N/X/S/L/R	**	**	**	033-70802-0	Vane Seal Backup Plate	4
C6	P/D/N/X/S/L/R	**	**	1	691-00120-0	Gasket O-ring	2
	P/D/N/X/S/L/R	**	**	4	694-00120-0		
	P/D/N/X/S/L/R	**	**	5	695-00120-0		
C7	P/D/N/X/S/L/R	**	**	**	033-70519-0	Vane Spacer	2
C8	P/D/N/X/S/L/R	**	**	**	033-70803-0	Check Valve	2
C9	P/D/N/X/S/L/R	2/3/7/8/9/10	**	**	033-53951-0	Rocker Cradle	1
	P/D/N/X/S/L/R	4/5	**	**	033-92281-0		
C10	P/X/S/L/R	**	**	**	033-70816-0	Vane Holddown	4
	D/V	**	**	**	033-72232-0		
C11	D/V	**	**	**	033-72233-0	Spring Holddown	8
	P/X/S/L/R	**	**	**	**	Not Required	**
	P/D/N/X/S/L/R	**	**	**	324-21624-0	Dowel Pins	4
C12	P/D/N/X/S/L/R	**	**	**	324-21624-0	Dowel Pins	4
	P/D/N/X/S/L/R	**	CCW	**	033-70612-0		
C13	P/D/N/X/S/L/R	**	CW	**	033-70572-0	Right Control Cover	1
	P/D/N/X/S/L/R	**	CCW	**	033-70574-0		
C14	P/D/N/X/S/L/R	**	CW	**	033-70571-0	Left Control Cover	1
	P/D/N/X/S/L/R	**	CW	**	306-40183-0		
C15	P/D/N/X/S/L/R	**	**	**	306-40183-0	Hex Hd Cap Screw	4
C16	P/D/N/X/S/L/R	**	**	**	306-40187-0	Hex Hd Cap Screw	4
	P/D/N/X/S/L/R	**	**	1	691-00904-0		
C17	P/D/N/X/S/L/R	**	**	4	694-00904-0	Gasket O-ring	2
	P/D/N/X/S/L/R	**	**	5	695-00904-0		
	P/D/N/X/S/L/R	**	**	**	488-35001-0		
C18	P/D/N/X/S/L/R	**	**	**	488-35001-0	Hex Socket Plug	2
	L/R	2/3/4/5/7/8/9/10	**	**	S23-12102-0	Cam Rocker	1
	P/X/S	2/3/4/5/7/8/9/10	**	**	S23-12105-0		
D/V	2/3/4/5/7/8/9/10	**	**	S23-12104-0			
C20	P/D/N/X/S/L/R	**	**	**	324-22412-0	Dowel Pin	2
C21	P/D/N/X/S/L/R	**	**	**	033-70524-0	Override Tube	2
C22	P/D/N/X/S/L/R	**	**	**	306-40188-0	Hex Hd Cap Screw	4

Cam & Cradle Assy Kits			
Includes items C1 Thru C22			
Part Number	Pump Type	Shaft Code	Rotation
S23-17234-0	P/X/S	2/3/7/8/9/10	CW
S23-17235-0	P/X/S	2/3/7/8/9/10	CCW
S23-17236-0	D/V	2/3/7/8/9/10	CW
S23-17237-0	D/V	2/3/7/8/9/10	CCW
S23-17238-0	R/L	2/3/7/8/9/10	CW
S23-17239-0	R/L	2/3/7/8/9/10	CCW



Pump Type P / D / V / X / S

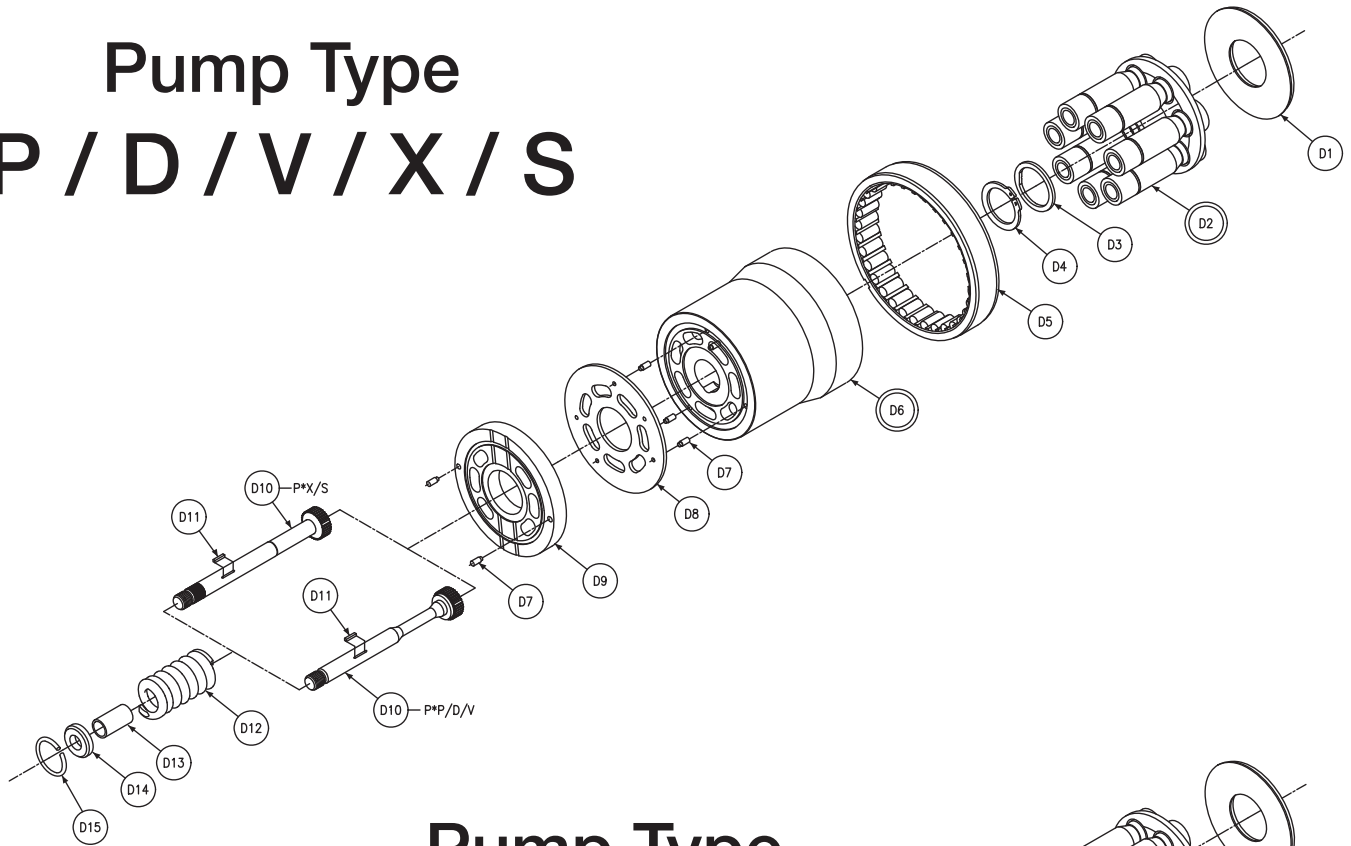

Pump Type R / L

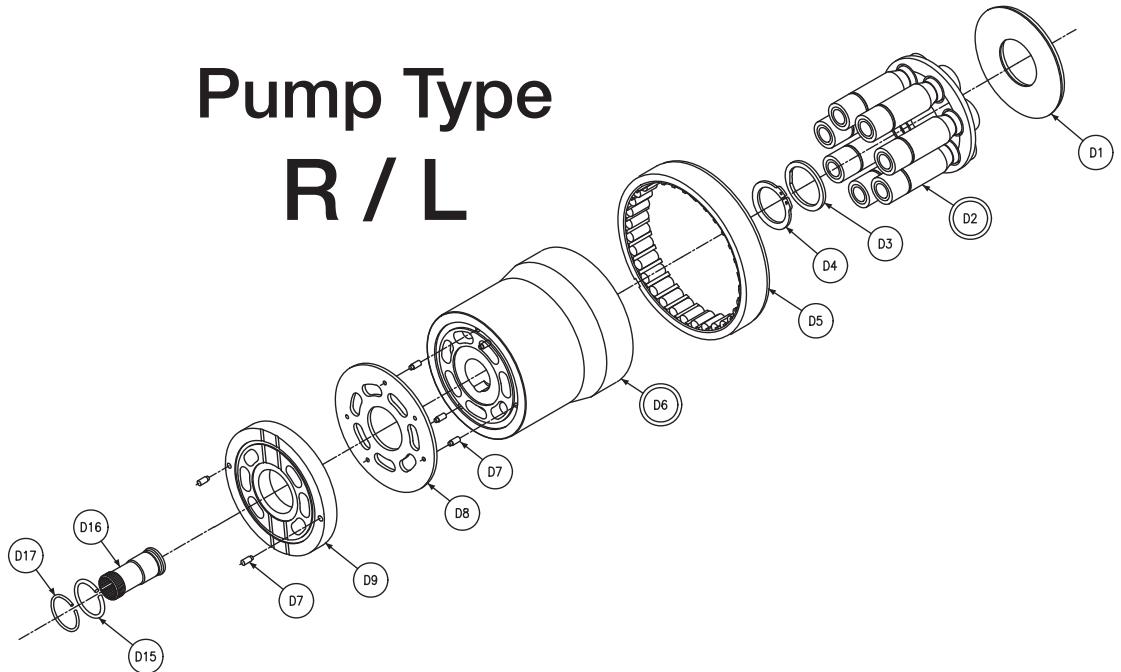

Section D						
P6/7/8 Rotating Group						
Balloon#	Displacement	Pump Type	Rotation	Item #	Description	Qty
D1	**	P/D/V/X/S/R/L	**	033-71261-0	Creep Plate	1
D2	P6	P/D/X/S/R/L	**	S13-43655-0	Piston Shoe & Retainer Assembly	1
	P7	P/D/X/S/R/L	**	S13-42308-0		
	P8	P/D/X/S/R/L	**	S21-11650-0		
	P6	V	**	S13-45375-0		
	P7	V	**	S13-47873-0		
D3	**	P/D/V/X/S/R/L	**	033-72249-0	Thrust Washer	1
	**	P/D/V/X/S/R/L	**	033-70484-0	Ret. Ring - .077" (1,96mm) Thk - Black	1
D4	**	P/D/V/X/S/R/L	**	033-70488-0	Ret. Ring - .079" (2,01mm) Thk - Red	
	**	P/D/V/X/S/R/L	**	033-70490-0	Ret. Ring - .081" (2,06mm) Thk - Green	
	**	P/D/V/X/S/R/L	**	035-72175-0	Ret. Ring - .083" (2,11mm) Thk - Yellow	
	**	P/D/V/X/S/R/L	**	035-72176-0	Ret. Ring - .085" (2,16mm) Thk - Blue	
D5	**	P/D/V/X/S/R/L	**	033-54826-0	Ret. Ring - .087" (2,21mm) Thk - White	1
	**	P/D/V/X/S/R/L	**	033-91107-0	Barrel Bearing	
D6	P6	P/D/V/X/S/R/L	**	S13-43657-0	Cylinder Barrel	1
	P7	P/D/V/X/S/R/L	**	S13-47511-0		
	P8	P/D/V/X/S/R/L	**	S23-12718-0		
D7	P6/7/8	P/D/V/X/S/R/L	**	033-49825-0	Face Plate Pin	5
D8	P6	P/D/V/X/S/R/L	**	033-71530-0	Face Plate	1
	P7/8	P/D/V/X/S/R/L	**	033-72532-0		
D9	P6	P/D/X/S/R/L	CW	033-71526-0	Port Plate	1
	P6	P/D/X/S/R/L	CCW	033-71525-0		
	P7	P/D/X/S/R/L	CW	033-72811-0		
	P7	P/D/X/S/R/L	CCW	033-53776-0		
	P8	P/D/X/S/R/L	CW	033-91252-0		
	P8	P/D/X/S/R/L	CCW	033-91553-0		
	P6	V	CW	031-59368-0		
	P6	V	CCW	031-59333-0		
	P7	V	CW	031-54509-0		
	P7	V	CCW	031-54508-0		
D10	**	P/D/V	**	033-53956-0	Auxiliary shaft	1
	**	S/X	**	033-91050-0		
D11	**	P/D/V/X/S	**	211-22034-0	Square Key	1
D12	**	P/D/V/X/S	**	033-70493-0	Holddown Spring	1
D13	**	P/D/V/X/S	**	033-53944-0	Holddown Stop	1
D14	**	P/D/V/X/S	**	033-53945-0	Spring Retainer	1
D15	**	P/D/V/X/S/R/L	**	033-70494-0	Retaining Ring	1
D16	**	R/L	**	033-57397-0	Holddown Sleeve	1
D17	**	R/L	**	033-57402-0	Retaining Ring	1

Major Rotating Group Kits			
Composed of Items: D1,D2,D5,D6,D7, D8 and D9			
Displacement	Pump Type	Rotation	Part Number
P6	P/D/X/S/R/L	CW	S23-17087-0
P6	P/D/X/S/R/L	CCW	S23-17088-0
P6	V	CW	S23-17093-0
P6	V	CCW	S23-17094-0
P7	P/D/X/S/R/L	CW	S23-17089-0
P7	P/D/X/S/R/L	CCW	S23-17090-0
P7	V	CW	S23-17095-0
P7	V	CCW	S23-17096-0
P8	P/D/X/S/R/L	CW	S23-17091-0
P8	P/D/X/S/R/L	CCW	S23-17092-0
P8	V	CW	S23-17097-0
P8	V	CCW	S23-17098-0

Barrel Hold Down Kits			
Composed of Items:			
D10,D12,D13,D14 and D15 For P/D/V/X/S			
No Kit Available for R/L Versions			
Displacement	Model Type	Rotation	Part Number
P6/7/8	P/D/V	**	S23-17246-0
P6/7/8	X/S	**	S23-17247-0



Reference
Section F
Valve Block Assembly

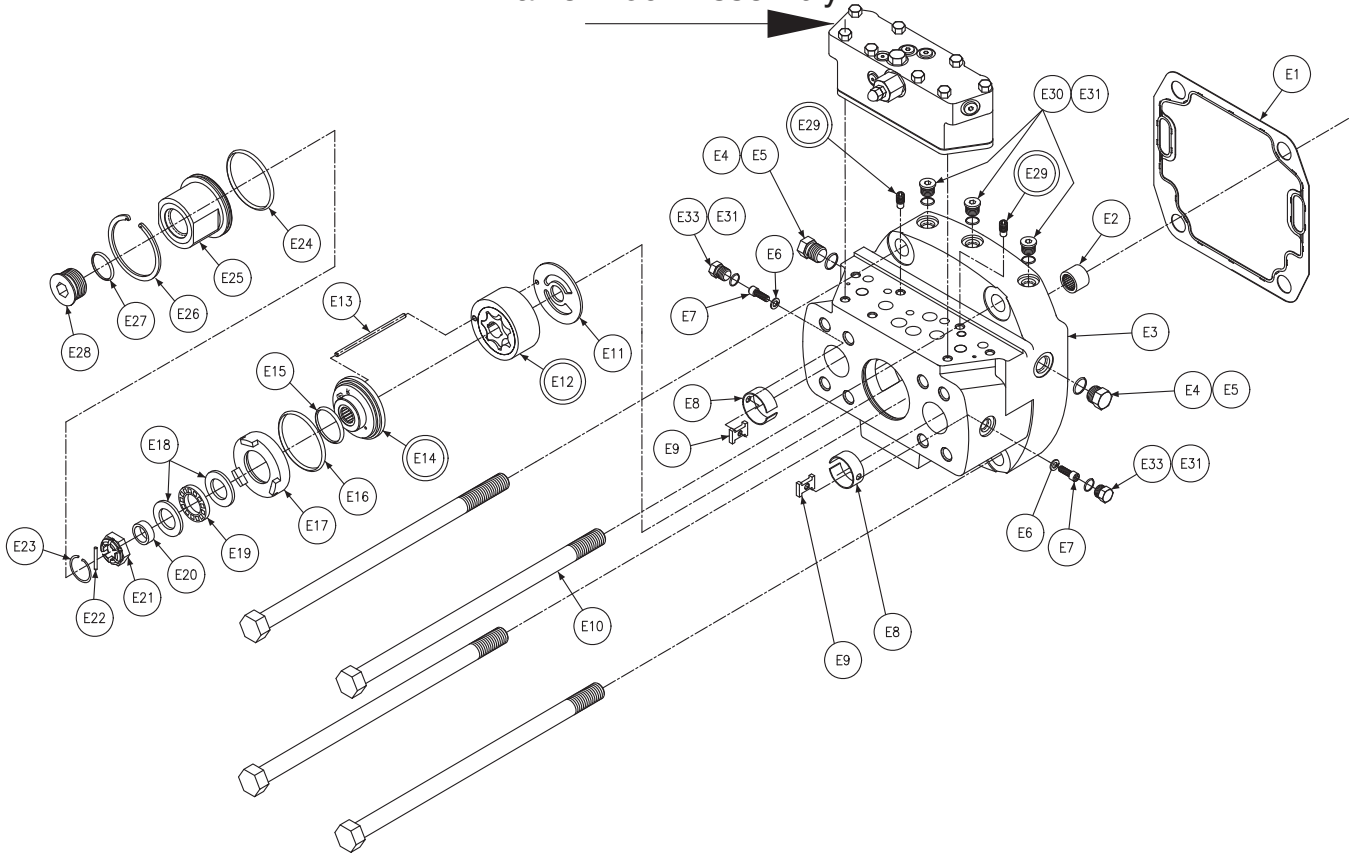

Section View - E - Pump Type - P & D - Port Block Assembly

Section E						
P6/7/8 P/D Port Block						
Balloon #	Pump Type	Rotation	Seal Code	Item #	Description	Qty
E1	P6/7/8 P/D	**	**	033-91060-0	Port Block Gasket Housing	1
E2	P6/7/8 P/D	**	**	230-82146-0	Needle Bearing	1
E3	P6/7/8 P/D	**	**	033-71296-0	Port Block	1
E4	P6/7/8 P/D	**	**	488-35002-0	Hex Hd Plug	2
E5	P6/7/8 P/D	**	1	691-00908-0	Gasket O-ring	2
	P6/7/8 P/D	**	4	694-00908-0		
	P6/7/8 P/D	**	5	695-00908-0		
E6	P6/7/8 P/D	**	**	348-10016-0	Washer, Lock	2
E7	P6/7/8 P/D	**	**	033-70908-0	Screw	2
E8	P6/7/8 P/D	**	**	033-70502-0	Ring Check, P6/7/8	2
E9	P6/7/8 P/D	**	**	033-70489-0	Clamp	2
E10	P6/7/8 P/D	**	**	306-40056-0	Hex Hd Cap Screw	4
E11	P6/7/8 P/D	**	**	033-71492-0	Side plate	1
E12	P6/7/8 P/D	**	**	S13-43334-0	Eccentric Ring and Gerotor	1
E13	P6/7/8 P/D	**	**	324-21225-0	Dowel Pin	1
E14	P6/7/8 P/D	CW	**	S13-46762-0	Side Plate and Bearing	1
	P6/7/8 P/D	CCW	**	S13-46763-0		
E15	P6/7/8 P/D	**	1	671-00129-0	Gasket O-ring	1
	P6/7/8 P/D	**	4	674-00129-0		
	P6/7/8 P/D	**	5	675-00129-0		
E16	P6/7/8 P/D	**	1	671-00144-0	Gasket O-ring	1
	P6/7/8 P/D	**	4	674-00144-0		
	P6/7/8 P/D	**	5	675-00144-0		
E17	P6/7/8 P/D	**	**	033-70531-0	Pressure Plate	1
E18	P6/7/8 P/D	**	**	350-10065-0	Thrust Washer	2
E19	P6/7/8 P/D	**	**	230-82131-0	Thrust Bearing	1
E20	P6/7/8 P/D	**	**	033-71490-0	Ring, Seal	1
E21	P6/7/8 P/D	**	**	033-53922-0	Holddown Nut	1
E22	P6/7/8 P/D	**	**	033-53921-0	Retaining Pin	1
E23	P6/7/8 P/D	**	**	033-53923-0	Ring, Retaining	1
E24	P6/7/8 P/D	**	1	671-00147-0	Gasket O-ring	1
	P6/7/8 P/D	**	4	674-00147-0		
	P6/7/8 P/D	**	5	675-00147-0		
E25	P6/7/8 P/D	**	**	033-72100-0	Auxiliary End Cover	1
E26	P6/7/8 P/D	**	**	356-65082-0	Ring, Retaining	1
E27	P6/7/8 P/D	**	1	691-00916-0	Gasket O-ring	1
	P6/7/8 P/D	**	4	694-00916-0		
	P6/7/8 P/D	**	5	695-00916-0		
E28	P6/7/8 P/D	**	**	488-35024-0	Plug	1
E29	P6/7/8 P/D	**	**	S13-40266-0	Check Valve	2
E30	P6/7/8 P/D	**	**	488-35041-0	Plug	3
E31	P6/7/8 P/D	**	1	691-00906-0	Gasket O-ring	5
	P6/7/8 P/D	**	4	694-00906-0		
	P6/7/8 P/D	**	5	695-00906-0		
E33	P6/7/8 P/D	**	**	488-35003-0	Hex Hd Plug	2

Gerotor Assembly Kit	Pump Type	Rotation	Part Number
Composed of Items: E2,E11,E12,	P/V/D/S/X	CW	S13-47314-0
E13,E14,E15,E16,E17,E18,E19,& E20	P/V/D/S/X	CCW	S13-47315-0
N/A for R/L Versions	P/V/D/S/X	CCW	S13-47315-0



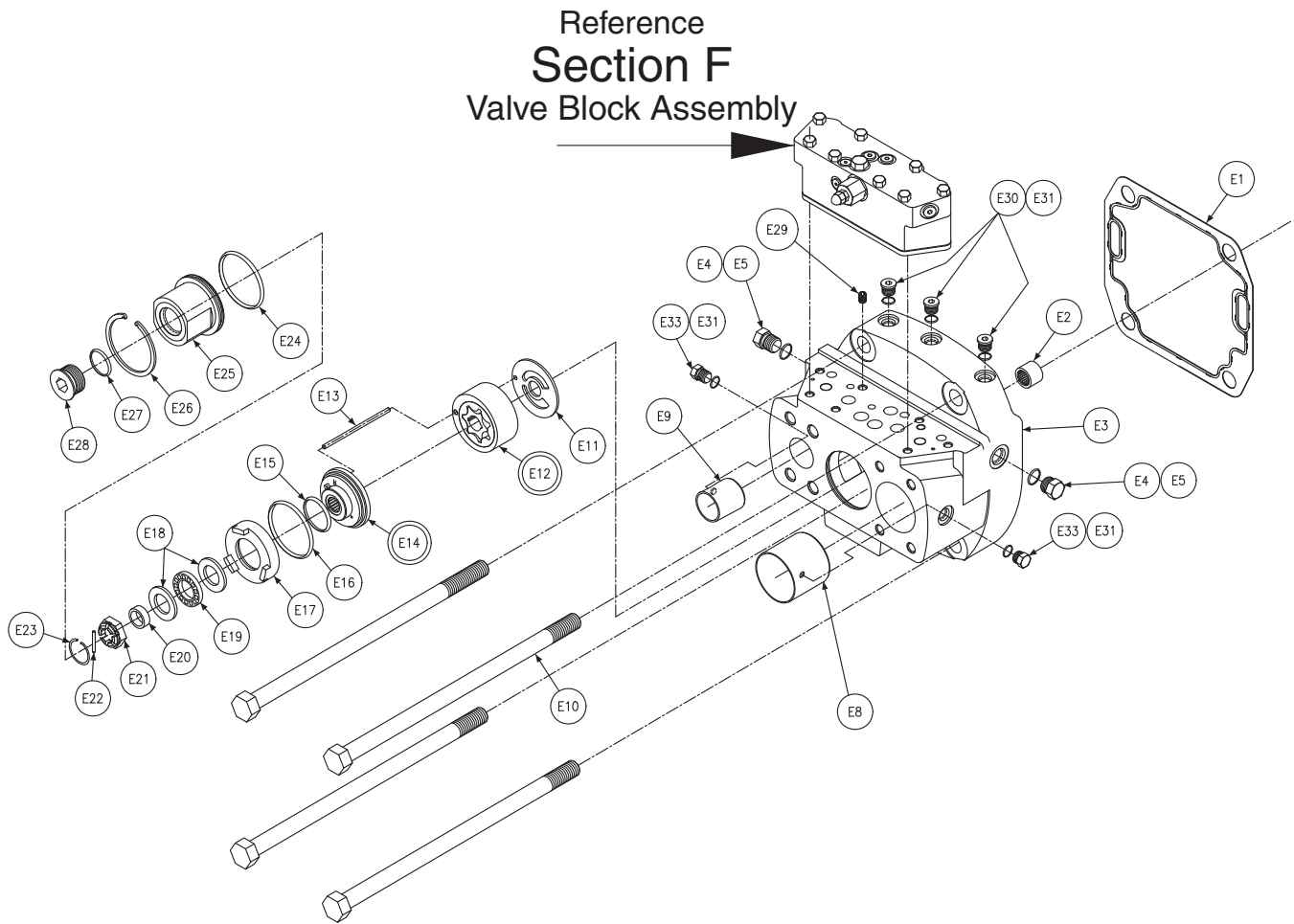

Section View - E - Pump Type - V - Port Block Assembly

Section E						
P6/7/8 V Port Block						
Balloon #	Pump Type	Rotation	Seal Code	Item #	Description	Qty
E1	P6/7/8 V	**	**	033-91060-0	Port block Gasket Housing	1
E2	P6/7/8 V	**	**	230-82146-0	Needle Bearing	1
E3	P6/7/8 V	**	**	033-71911-0	Port Block	1
E4	P6/7/8 V	**	**	488-35002-0	Hex Hd Plug	2
E5	P6/7/8 V	**	1	691-00908-0	Gasket O-ring	2
	P6/7/8 V	**	4	694-00908-0		
	P6/7/8 V	**	5	695-00908-0		
E8	P6/7/8 V	**	**	033-91180-0	Sold Sleeve, P6/7/8 V "A" Port	1
E9	P6/7/8 V	**	**	033-57893-0	Sold Sleeve, P6/7/8 V "B" Port	1
E10	P6/7/8 V	**	**	306-40056-0	Hex Hd Cap Screw	4
E11	P6/7/8 V	**	**	033-71492-0	Side Plate	1
E12	P6/7/8 V	**	**	S13-43334-0	Eccentric Ring and Gerotor	1
E13	P6/7/8 V	**	**	324-21225-0	Dowel Pin	1
E14	P6/7/8 V	CW	**	S13-46762-0	Side Plate and Bearing	1
	P6/7/8 V	CCW	**	S13-46763-0		
E15	P6/7/8 V	**	1	671-00129-0	Gasket O-ring	1
	P6/7/8 V	**	4	674-00129-0		
	P6/7/8 V	**	5	675-00129-0		
E16	P6/7/8 V	**	1	671-00144-0	Gasket O-ring	1
	P6/7/8 V	**	4	674-00144-0		
	P6/7/8 V	**	5	675-00144-0		
E17	P6/7/8 V	**	**	033-70531-0	Pressure Plate	1
E18	P6/7/8 V	**	**	350-10065-0	Thrust Washer	2
E19	P6/7/8 V	**	**	230-82131-0	Thrust Bearing	1
E20	P6/7/8 V	**	**	033-71490-0	Ring, Seal	1
E21	P6/7/8 V	**	**	033-53922-0	Holddown Nut	1
E22	P6/7/8 V	**	**	033-53921-0	Retaining Pin	1
E23	P6/7/8 V	**	**	033-53923-0	Ring, Retaining	1
E24	P6/7/8 V	**	1	671-00147-0	Gasket O-ring	1
	P6/7/8 V	**	4	674-00147-0		
	P6/7/8 V	**	5	675-00147-0		
E25	P6/7/8 V	**	**	033-72100-0	Auxiliary End Cover	1
E26	P6/7/8 V	**	**	356-65082-0	Ring, Retaining	1
E27	P6/7/8 V	**	1	691-00916-0	Gasket O-ring	1
	P6/7/8 V	**	4	694-00916-0		
	P6/7/8 V	**	5	695-00916-0		
E28	P6/7/8 V	**	**	488-35024-0	Plug	1
E29	P6/7/8 V	**	**	353-25037-0	Set Screw	1
E30	P6/7/8 V	**	**	488-35041-0	Plug	3
E31	P6/7/8 V	**	1	691-00906-0	Gasket O-ring	5
	P6/7/8 V	**	4	694-00906-0		
	P6/7/8 V	**	5	695-00906-0		
E33	P6/7/8 V	**	**	488-35003-0	Hex Hd Plug	2



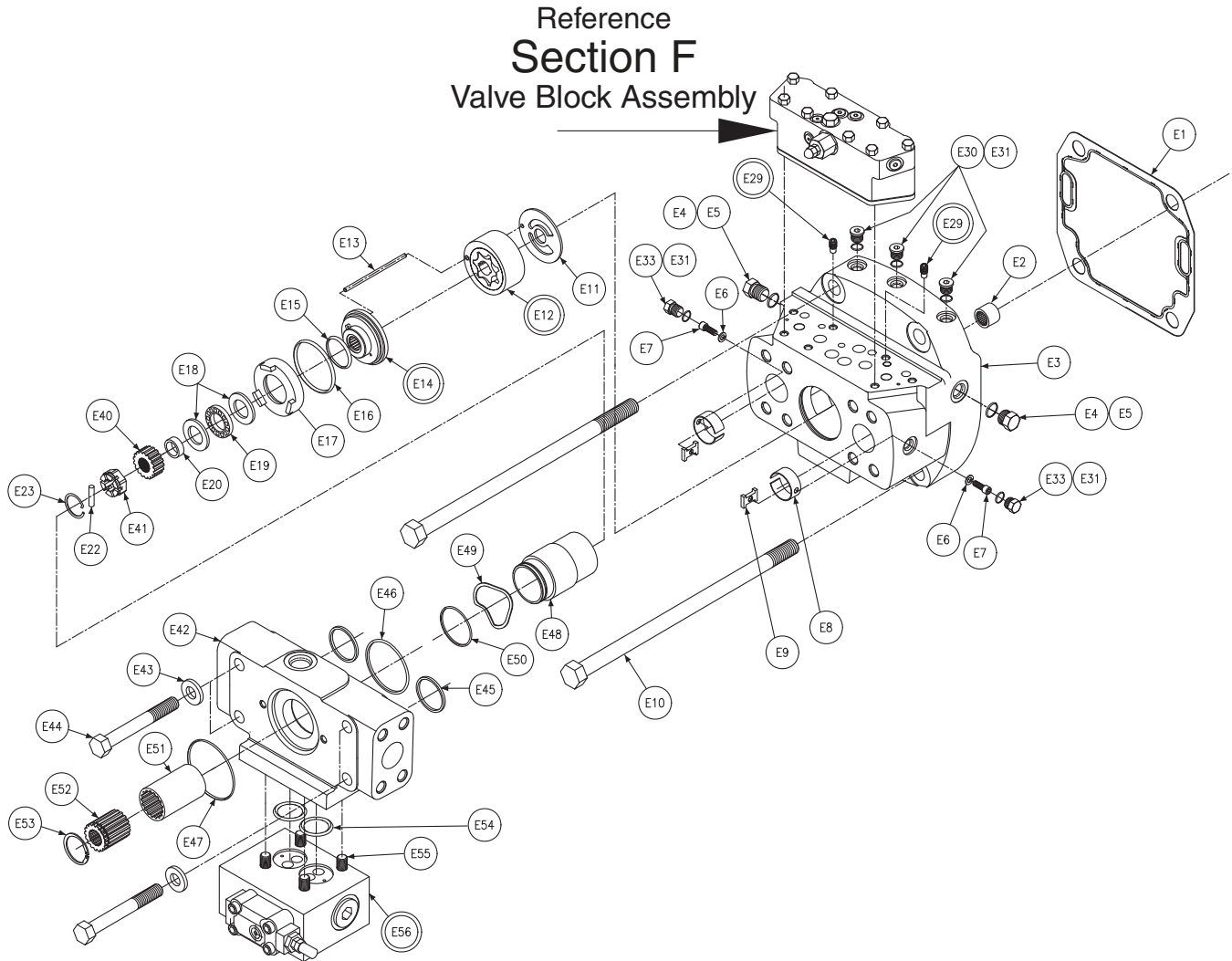

Section E							
P6/7/8 S & X Port Block							
Balloon #	Pump Type	Rotation	Seal Code	Thru Drive	Item #	Description	Qty
E1	P6/7/8 S&X	**	**	**	033-91060-0	Port Block Gasket Housing	1
E2	P6/7/8 S&X	**	**	**	230-82146-0	Needle Bearing	1
E3	P6/7/8 S&X	**	**	**	033-71296-0	Port Block	1
E4	P6/7/8 S&X	**	**	**	488-35002-0	Hex Hd Cap Screw	2
E5	P6/7/8 S&X	**	1	**	691-00908-0	Gasket O-ring	2
	P6/7/8 S&X	**	4	**	694-00908-0		
	P6/7/8 S&X	**	5	**	695-00908-0		
E6	P6/7/8 S&X	**	**	**	348-10016-0	Washer, Lock	2
E7	P6/7/8 S&X	**	**	**	033-70908-0	Screw	2
E8	P6/7/8 S&X	**	**	**	033-70502-0	Ring Check, P6/7/8	2
E9	P6/7/8 S&X	**	**	**	033-70489-0	Clamp	2

P6/7/8 S & X Port Block (CONTINUED)

Continued on next page.



Section View - E - Pump Type - S & X - Port Block Assembly

Balloon #	Pump Type	Rotation	Seal Code	Thru Drive	Item #	Description	Qty
E10	P6/7/8 S&X	**	**	**	306-40056-0	Hex Hd Cap Screw	4
E11	P6/7/8 S&X	**	**	**	033-71492-0	Side Plate	1
E12	P6/7/8 S&X	**	**	**	S13-43334-0	Eccentric Ring and Gerotor	1
E13	P6/7/8 S&X	**	**	**	324-21225-0	Dowel Pin	1
E14	P6/7/8 S&X	CW	**	**	S13-46762-0	Side Plate and Bearing	1
	P6/7/8 S&X	CCW	**	**	S13-46763-0		
E15	P6/7/8 S&X	**	1	**	671-00129-0	Gasket O-ring	1
	P6/7/8 S&X	**	4	**	674-00129-0		
	P6/7/8 S&X	**	5	**	675-00129-0		
E16	P6/7/8 S&X	**	1	**	671-00144-0	Gasket O-ring	1
	P6/7/8 S&X	**	4	**	674-00144-0		
	P6/7/8 S&X	**	5	**	675-00144-0		
E17	P6/7/8 S&X	**	**	**	033-70531-0	Pressure Plate	1
E18	P6/7/8 S&X	**	**	**	350-10081-0	Thrust Washer	2
E19	P6/7/8 S&X	**	**	**	230-82164-0	Thrust Bearing	1
E20	P6/7/8 S&X	**	**	**	033-72101-0	Ring, Seal	1
E22	P6/7/8 S&X	**	**	**	033-53921-0	Retaining Pin	1
E23	P6/7/8 S&X	**	**	**	033-53923-0	Ring, Retaining	1
E29	P6/7/8 S&X	**	**	**	S13-40266-0	Check Valve	2
E30	P6/7/8 S&X	**	**	**	488-35041-0	Plug	3
E31	P6/7/8 S&X	**	1	**	691-00906-0	Gasket O-ring	5
	P6/7/8 S&X	**	4	**	694-00906-0		
	P6/7/8 S&X	**	5	**	695-00906-0		
E33	P6/7/8 S&X	**	**	**	488-35003-0	Hex Hd Plug	2
E40	P6/7/8 S&X	**	**	**	033-91051-0	Insert	1
E41	P6/7/8 S&X	**	**	**	033-91052-0	Holddown Nut	1
E42	P6/7/8 S	**	**	A	033-91015-0	SAE A Rear Drive Adapter	1
	P6/7/8 S	**	**	B	033-57967-0	SAE B Rear Drive Adapter	
	P6/7/8 X	**	**	A	033-57958-0	SAE A Rear Drive Adapter	
	P6/7/8 X	**	**	B	033-57957-0	SAE B Rear Drive Adapter	
E43	P6/7/8 S&X	**	**	**	350-10136-0	Washer	4
E44	P6/7/8 S&X	**	**	**	306-40088-0	Hex Hd Cap Screw	4
E45	P6/7/8 S&X	**	1	**	691-10131-0	Gasket O-ring	2
	P6/7/8 S&X	**	4	**	694-10131-0		
	P6/7/8 S&X	**	5	**	695-10131-0		
E46	P6/7/8 S&X	**	1	**	671-00147-0	Gasket O-ring	1
	P6/7/8 S&X	**	4	**	674-00147-0		
	P6/7/8 S&X	**	5	**	675-00147-0		
E47	P6/7/8 S&X	**	1	**	671-00155-0	Gasket O-ring	1
	P6/7/8 S&X	**	4	**	674-00155-0		
	P6/7/8 S&X	**	5	**	675-00155-0		
E48	P6/7/8 S&X	**	**	**	033-57966-0	Replenish Isolation Tube	1
E49	P6/7/8 S&X	**	**	**	225-92093-0	Wave Spring	1
E50	P6/7/8 S&X	**	1	**	671-00033-0	Gasket O-ring	1
	P6/7/8 S&X	**	4	**	674-00033-0		
	P6/7/8 S&X	**	5	**	675-00033-0		
E51	P6/7/8 S&X	**	**	**	033-57963-0	Coupling	1
E52	P6/7/8 S&X	**	**	A	033-57965-0	SAE A Insert	1
	P6/7/8 S&X	**	**	B	033-57964-0	SAE B Insert	
E53	P6/7/8 S&X	**	**	**	356-65128-0	Ring, Retaining	1
E54	P6/7/8 S	**	1	**	691-10221-0	Gasket O-ring	2
	P6/7/8 S	**	4	**	694-10221-0		
	P6/7/8 S	**	5	**	695-10221-0		
E55	P6/7/8 S	**	**	**	306-40224-0	Hex Hd Cap Screw	4
E56	P6/7/8 S	**	1	**	08003010003	Hot Oil Shuttle Int Pilot Drain	1



Reference
Section F
Valve Block Assembly

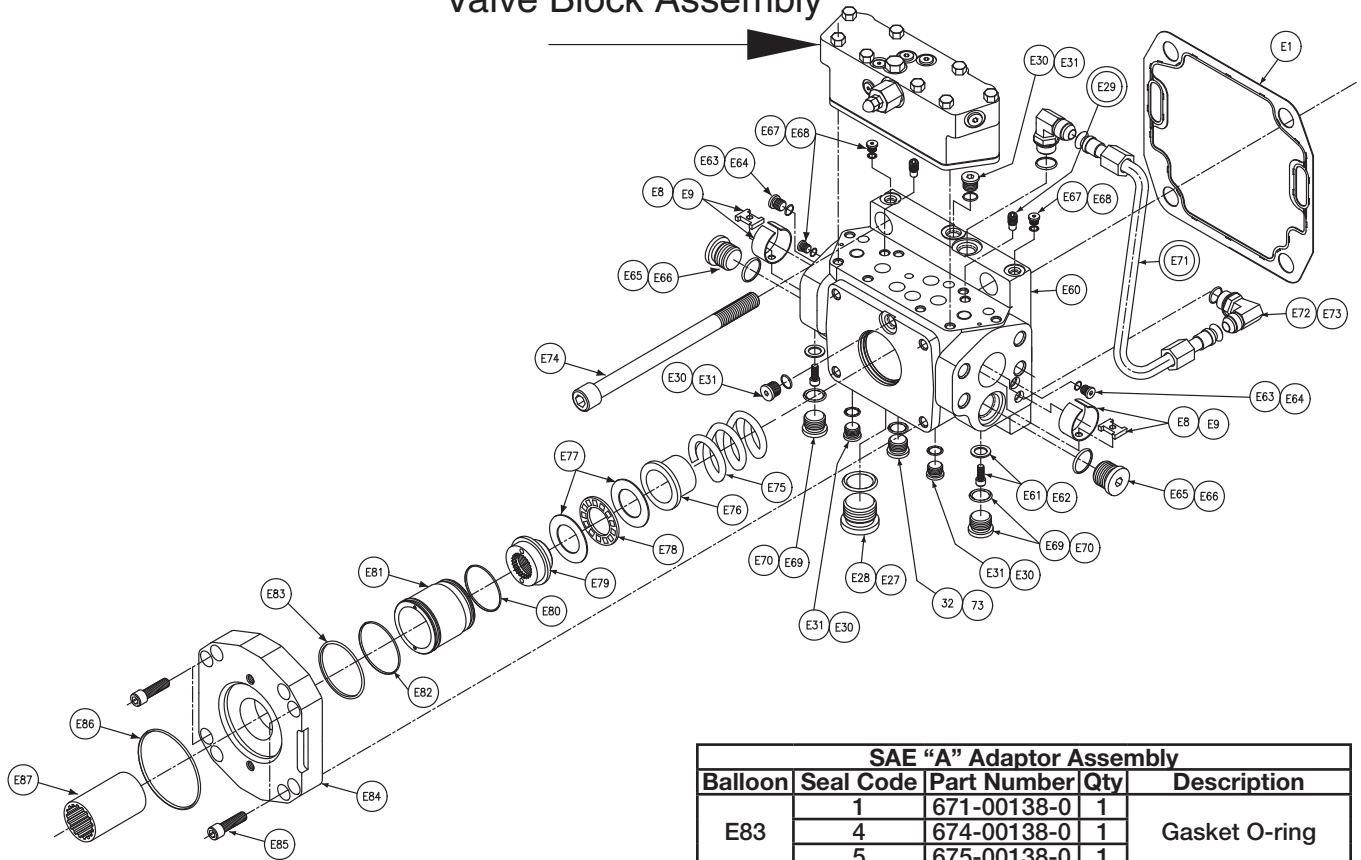

SAE "A" Adaptor Assembly				
Balloon	Seal Code	Part Number	Qty	Description
E83	1	671-00138-0	1	Gasket O-ring
	4	674-00138-0	1	
	5	675-00138-0	1	
E84	**	033-92412-0	1	SAE "A" Adaptor
E85	**	358-18180-0	4	Hex Socket Hd Cap Screw
E86	1	671-00152-0	1	Gasket O-ring
	4	674-00152-0	1	
	5	675-00152-0	1	
E87	**	033-92413-0	1	SAE "A" Coupling
Kit P/N S23-15868-0 Contains All Above				

SAE "B" Adaptor Assembly				
Balloon	Seal Code	Part Number	Qty	Description
E83	1	671-00138-0	1	Gasket O-ring
	4	674-00138-0	1	
	5	675-00138-0	1	
E84	**	033-57535-0	1	SAE "B" Adaptor
E85	**	358-18200-0	4	Hex Socket Hd Cap Screw
E86	1	671-00155-0	1	Gasket O-ring
	4	674-00155-0	1	
	5	675-00155-0	1	
E87	**	033-57714-0	1	SAE "B" Coupling
Kit P/N S23-16884-0 Contains All Above				

SAE "C" Adaptor Assembly				
Balloon	Seal Code	Part Number	Qty	Description
E83	1	671-00138-0	1	Gasket O-ring
	4	674-00138-0	1	
	5	675-00138-0	1	
E84	**	033-57395-0	1	SAE "C" Adaptor
E85	**	358-18200-0	4	Hex Socket Hd Cap Screw
E86	1	671-00250-0	1	Gasket O-ring
	4	674-00250-0	1	
	5	675-00250-0	1	
E87	**	033-57398-0	1	SAE "C" Coupling
Kit P/N S23-16885-0 Contains All Above				



Section View - E - Pump Type - R - Port Block Assembly

Section E						
P6/7/8 R Port block						
Balloon#	Pump Type	Seal Code	Thru Drive	Item #	Description	Qty
E1	P6/7/8 R	**	**	033-91061-0	Port Block Gasket Housing	1
E8	P6/7/8 R	**	**	033-70502-0	Ring Check, P6/7/8 P&D	2
E9	P6/7/8 R	**	**	033-70489-0	Clamp	2
E27	P6/7/8 R	1	**	691-00916-0	Gasket O-ring	1
	P6/7/8 R	4	**	694-00916-0		
	P6/7/8 R	5	**	695-00916-0		
E28	P6/7/8 R	**	**	488-35024-0	Plug	1
E29	P6/7/8 R	**	**	S13-40266-0	Check Valve	2
E30	P6/7/8 R	**	**	488-35041-0	Plug	4
E31	P6/7/8 R	1	**	691-00906-0	Gasket O-ring	4
	P6/7/8 R	4	**	694-00906-0		
	P6/7/8 R	5	**	695-00906-0		
E32	P6/7/8 R	**	**	488-35018-0	Plug	1
E60	P6/7/8 R	**	**	033-57696-0	Port Block	1
E61	P6/7/8 R	**	**	359-00001-0	Screw	2
E62	P6/7/8 R	**	**	033-57450-0	Washer, Gasket	2
E63	P6/7/8 R	**	**	488-35046-0	Plug	2
E64	P6/7/8 R	1	**	691-00902-0	Gasket O-ring	2
	P6/7/8 R	4	**	694-00902-0		
	P6/7/8 R	5	**	695-00902-0		
E65	P6/7/8 R	**	**	033-57408-0	Plug	2
E66	P6/7/8 R	1	**	691-00912-0	Gasket O-ring	2
	P6/7/8 R	4	**	694-00912-0		
	P6/7/8 R	5	**	695-00912-0		
E67	P6/7/8 R	**	**	488-35001-0	Plug	3
E68	P6/7/8 R	1	**	691-00904-0	Gasket O-ring	3
	P6/7/8 R	4	**	694-00904-0		
	P6/7/8 R	5	**	695-00904-0		
E69	P6/7/8 R	**	**	488-35055-0	Plug	2
E70	P6/7/8 R	**	**	691-00910-0	Gasket O-ring	2
	P6/7/8 R	**	**	674-00910-0		
	P6/7/8 R	**	**	695-00910-0		
E71	P6/7/8 R	**	**	S23-17195-0	Tube Assembly	1
E72	P6/7/8 R	**	**	496-15001-0	Elbow	2
E73	P6/7/8 R	1	**	691-00908-0	Gasket O-ring	3
	P6/7/8 R	4	**	694-00908-0		
	P6/7/8 R	5	**	695-00908-0		
E74	P6/7/8 R	**	**	358-24540-0	Hex socket Hd Cap Screw	4
E75	P6/7/8 R	**	**	033-57400-0	Holddown Spring	1
E76	P6/7/8 R	**	**	033-57401-0	Holddown Stop	1
E77	P6/7/8 R	**	**	350-10114-0	Washer	2
E78	P6/7/8 R	**	**	230-82195-0	Bearing, Thrust	1
E79	P6/7/8 R	**	**	033-57396-0	Hold Down Nut	1
E80	P6/7/8 R	1	**	671-00136-0	Gasket O-ring	1
	P6/7/8 R	4	**	674-00136-0		
	P6/7/8 R	5	**	675-00136-0		
E81	P6/7/8 R	**	**	033-57407-0	Replenish Isolation Tube	1
E82	P6/7/8 R	1	**	671-00138-0	Gasket O-ring	1
	P6/7/8 R	4	**	674-00138-0		
	P6/7/8 R	5	**	675-00138-0		



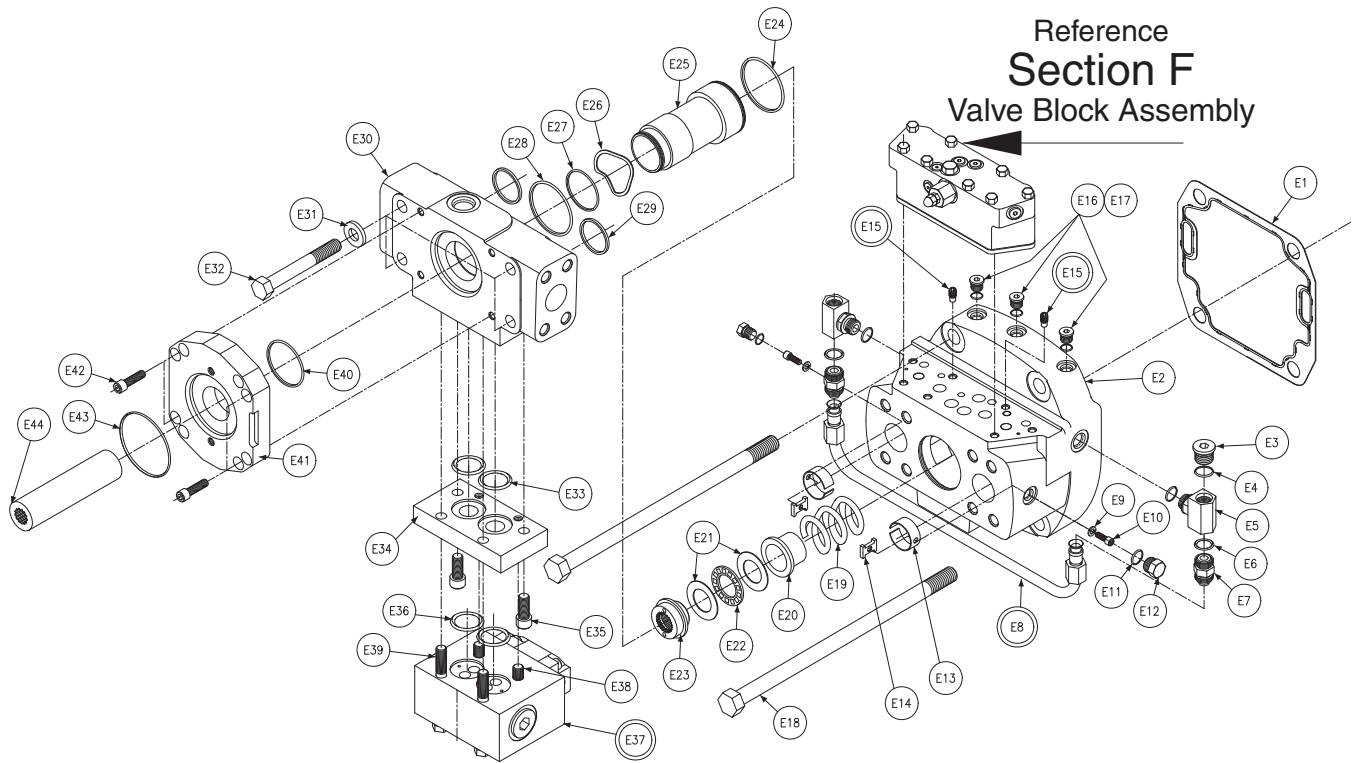

SAE "A" Adaptor Assembly				
Balloon	Seal Code	Part Number	Qty	Description
E40	1	671-00138-0	1	Gasket O-ring
	4	674-00138-0		
	5	675-00138-0		
E41	**	033-92412-0	1	SAE "A" Adaptor
E42	**	358-18180-0	4	Soc Hd Cap Screw
E43	1	671-00152-0	1	Gasket O-ring
	4	674-00152-0	1	
	5	675-00152-0	1	
E44	**	033-93454-0	1	SAE "A" Coupling
No Adaptor Kit Part Number Available for L Pumps				

SAE "B" Adaptor Assembly				
Balloon	Seal Code	Part Number	Qty	Description
E40	1	671-00138-0	1	Gasket O-ring
	4	674-00138-0		
	5	675-00138-0		
E41	**	033-57535-0	1	SAE "B" Adaptor
E42	**	358-18200-0	4	Soc Hd Cap screw
E43	1	671-00155-0	1	Gasket O-ring
	4	674-00155-0	1	
	5	675-00155-0	1	
E44	**	033-94248-0	1	SAE "B" Coupling

No Adaptor Kit Part Number Available for L Pumps				
SAE "C" Adaptor				
Balloon	Seal Code	Part Number	Qty	Description
E40	1	671-00138-0	1	Gasket O-ring
	4	674-00138-0		
	5	675-00138-0		
E41	**	033-57395-0	1	SAE "C" Adaptor
E42	**	358-18200-0	4	Soc Hd Cap Screw
E43	1	671-00250-0	1	Gasket O-ring
	4	674-00250-0	1	
	5	675-00250-0	1	
E44	**	S23-18306-0	1	SAE "C" Coupling
No Adaptor Kit Part Number Available for L Pumps				



Section View - E - Pump Type - L - Port Block Assembly

Section E					
P6/7/8 L Port Block					
Balloon#	Pump Type	Seal Code	Item #	Description	Qty
E1	P6/7/8 L	**	033-91060-0	Port Block Gasket Housing	1
E2	P6/7/8 L	**	033-92951-0	Port Block	1
E3	P6/7/8 L	**	488-35055-0	Plug	2
E4	P6/7/8 L	**	691-00910-0	Gasket O-ring	2
	P6/7/8 L	**	674-00910-0		
	P6/7/8 L	**	695-00910-0		
E5	P6/7/8 L	**	492-15445-0	Branch Tee	2
E6	P6/7/8 L	1	691-00908-0	Gasket O-ring	4
	P6/7/8 L	4	694-00908-0		
	P6/7/8 L	5	695-00908-0		
E7	P6/7/8 L	**	493-15015-0	Connector	2
E8	P6/7/8 L	**	S23-16518-0	Crossover Tube Assembly	1
E9	P6/7/8 L	**	348-10016-0	Washer, Lock	2
E10	P6/7/8 L	**	033-70908-0	Screw	2
E11	P6/7/8 L	1	691-00906-0	Gasket O-ring	2
	P6/7/8 L	4	694-00906-0		
	P6/7/8 L	5	695-00906-0		
E12	P6/7/8 L	**	488-35003-0	Hex Hd Plug	2
E13	P6/7/8 L	**	033-70502-0	Ring Check	2
E14	P6/7/8 L	**	033-70489-0	Clamp	2
E15	P6/7/8 L	**	S13-40266-0	Check Valve	2
E16	P6/7/8 L	**	488-35041-0	Plug	3
E17	P6/7/8 L	1	691-00906-0	Gasket O-ring	3
	P6/7/8 L	4	694-00906-0		
	P6/7/8 L	5	695-00906-0		
E18	P6/7/8 L	**	306-40056-0	Hex Hd Cap Screw	4
E19	P6/7/8 L	**	033-57400-0	Holddown Spring	1
E20	P6/7/8 L	**	033-57401-0	Holddown Stop	1
E21	P6/7/8 L	**	350-10114-0	Washer - Thrust	2
E22	P6/7/8 L	**	230-82195-0	Bearing - Thrust	1
E23	P6/7/8 L	**	033-57396-0	Hold Down Nut	1
E24	P6/7/8 L	1	671-00038-0	Gasket O-ring	1
	P6/7/8 L	4	674-00038-0		
	P6/7/8 L	5	675-00038-0		
E25	P6/7/8 L	**	033-92953-0	Replenish Isolation Tube	1
E26	P6/7/8 L	**	225-92093-0	Spring - Wave	1
E27	P6/7/8 L	1	671-00033-0	Gasket O-ring	1
	P6/7/8 L	4	674-00033-0		
	P6/7/8 L	5	675-00033-0		
E28	P6/7/8 L	1	671-00147-0	Gasket O-ring	1
	P6/7/8 L	4	674-00147-0		
	P6/7/8 L	5	675-00147-0		
E29	P6/7/8 L	1	691-10131-0	Gasket O-ring	2
	P6/7/8 L	4	694-10131-0		
	P6/7/8 L	5	695-10131-0		
E30	P6/7/8 L	**	033-92952-0	Adapter P blk Aux Mtg	1
E31	P6/7/8 L	**	350-10136-0	Washer	4
E32	P6/7/8 L	**	306-40088-0	Hex Hd Cap Screw	4
E33	P6/7/8 L	1	691-10221-0	Gasket O-ring	2
	P6/7/8 L	4	694-10221-0		
	P6/7/8 L	5	695-10221-0		
E34	P6/7/8 L	**	033-92954-0	Shuttle Spacer	1
E35	P6/7/8 L	**	358-20160-0	Socket Head Screw	2
E36	P6/7/8 L	1	691-10221-0	Gasket O-ring	2
	P6/7/8 L	4	694-10221-0		
	P6/7/8 L	5	695-10221-0		
E37	P6/7/8 L	1	080030100003	Hot Oil Shuttle Int Pilot Drain	1
E38	P6/7/8 L	**	306-40224-0	Hex Hd Cap Screw	2
E39	P6/7/8 L	**	306-40175-0	Hex Hd Cap Screw	2



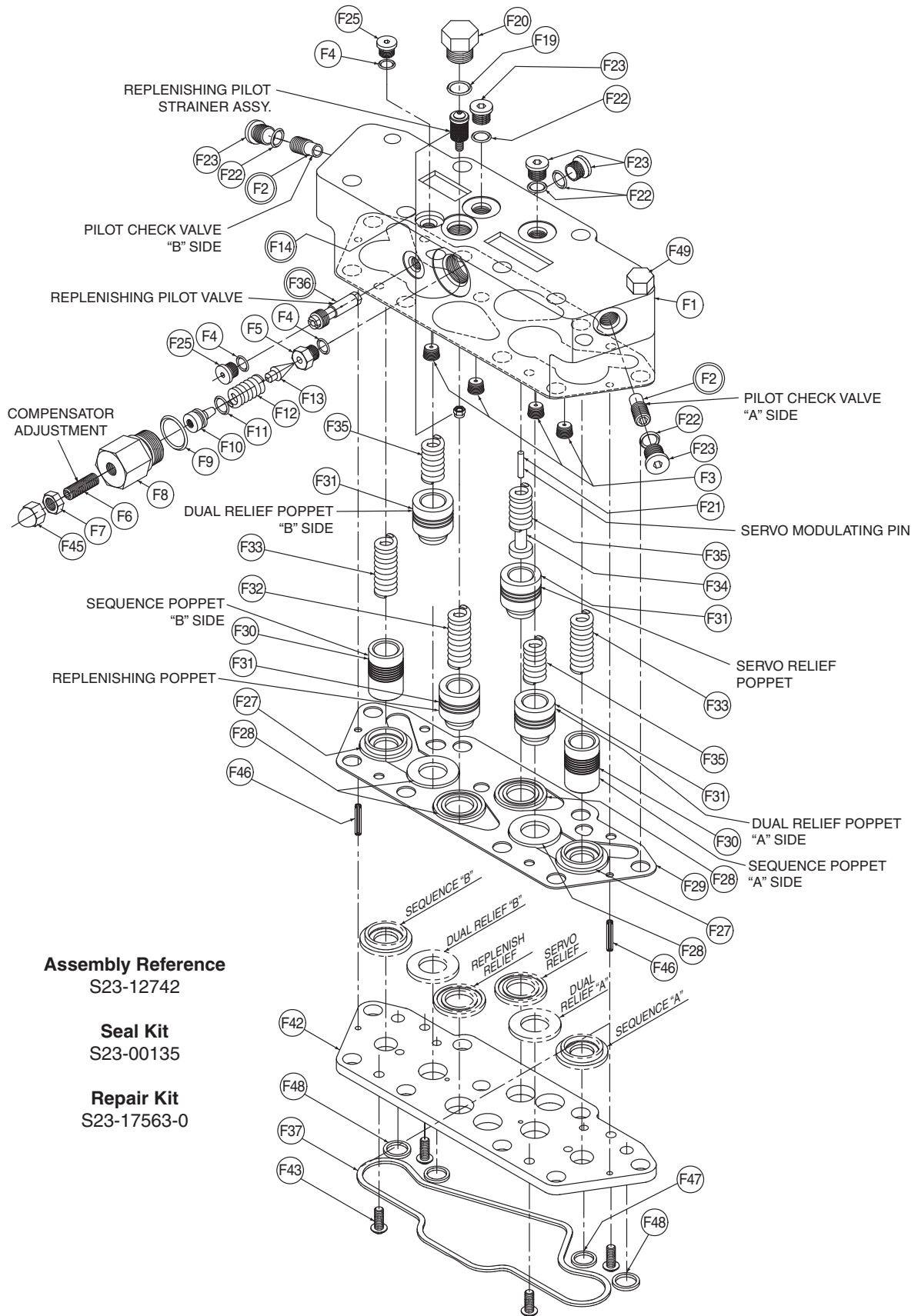

Assembly Reference
S23-12742

Seal Kit
S23-00135

Repair Kit
S23-17563-0



Section F				
Valve Block Assembly (Reference S23-12742)				
Balloon #	Seal Code	Item #	Description	Qty
F1	**	033-91221-0	Valve Body	1
F2	**	S13-40266-0	Valve Check	2
F3	**	033-91249-0	.046 Dia. Orifice Plug	4
F4	1	691-00903-0	Gasket O-ring	3
	4	694-00903-0		
	5	695-00903-0		
F5	**	033-70508-0	Seat	1
F6	**	312-13160-0	Screw-socket hd	1
F7	**	335-13100-0	Nut-Jam	1
F8	**	033-70545-0	Housing Guide	1
F9	1	691-00910-0	Gasket O-ring	1
	4	694-00910-0		
	5	695-00910-0		
F10	**	033-21767-0	Piston	1
F11	1	671-00012-0	Gasket O-ring	1
	4	674-00012-0		
	5	675-00012-0		
F12	**	032-91798-0	Spring	1
F13	**	036-12288-0	Cone	1
F14	**	S13-43240-0	Assy, Repl Strainer	1
F19	1	691-00906-0	Gasket O-ring	1
	4	694-00906-0		
	5	695-00906-0		
F20	**	488-35003-0	Plug	1
F21	**	230-82226-0	Pin 1/8X5/8 (P units)	1
F22	1	691-00904-0	Gasket O-ring	5
	4	694-00904-0		
	5	695-00904-0		
F23	**	488-35001-0	Plug	5
F25	**	488-35049-0	Plug	2
F27	**	033-70507-0	Seat, Sequence	2
F28	**	033-70500-0	Seat, Repl & Servo	4
F29	**	033-91193-0	Gasket, Valve Block	1
F30	**	033-72378-0	Poppet, Sequence	2
F31	**	033-72379-0	Poppet, Dual & Repl.	4
F32	**	033-22141-0	Spring, Repl.	1
F33	**	033-70512-0	Spring, Sequence	2
F34	**	033-70482-0	Spring, Retainer	1
F35	**	033-71086-0	Spring, Dual Relief	3
F36	**	S23-12814-0	Pilot Valve - Repl Relief	1
F37	1	671-00050-0	Gasket O-ring	1
	4	674-00050-0		
	5	675-00050-0		
F42	**	033-91422-0	Plate, Retainer	1
F43	**	353-25078-0	Screw, Button Head	4
F45	**	327-25006-0	Nut, Acron	1
F46	**	325-08120-0	Pin, Spring	2
F47	1	671-00013-0	Gasket O-ring	2
	4	674-00013-0		
	5	675-00013-0		
F48	1	671-00014-0	Gasket O-ring	2
	4	674-00014-0		
	5	675-00014-0		
F49	**	306-40169-0	Screw, HHC 3/8-16 UNC X 3 1/4 Lg. Grade 8	8



Offer of Sale

The items described in this document and other documents and descriptions provided by Parker Hannifin Corporation, Hydraulics Group, and its authorized distributors ("Seller") are hereby offered for sale at prices to be established by Seller. This offer and its acceptance by any customer ("Buyer") shall be governed by all of the following Terms and Conditions. Buyer's order for any item described in its document, when communicated to Seller verbally, or in writing, shall constitute acceptance of this offer. All goods or work described will be referred to as "Products".

1. **Terms and Conditions.** Seller's willingness to offer Products, or accept an order for Products, to or from Buyer is expressly conditioned on Buyer's assent to these Terms and Conditions and to the terms and conditions found on-line at www.parker.com/saleterms/. Seller objects to any contrary or additional term or condition of Buyer's order or any other document issued by Buyer.
2. **Price Adjustments; Payments.** Prices stated on the reverse side or preceding pages of this document are valid for 30 days. After 30 days, Seller may change prices to reflect any increase in its costs resulting from state, federal or local legislation, price increases from its suppliers, or any change in the rate, charge, or classification of any carrier. The prices stated on the reverse or preceding pages of this document do not include any sales, use, or other taxes unless so stated specifically. Unless otherwise specified by Seller, all prices are F.O.B. Seller's facility, and payment is due 30 days from the date of invoice. After 30 days, Buyer shall pay interest on any unpaid invoices at the rate of 1.5% per month or the maximum allowable rate under applicable law.
3. **Delivery Dates; Title and Risk; Shipment.** All delivery dates are approximate and Seller shall not be responsible for any damages resulting from any delay. Regardless of the manner of shipment, title to any products and risk of loss or damage shall pass to Buyer upon tender to the carrier at Seller's facility (i.e., when it's on the truck, it's yours). Unless otherwise stated, Seller may exercise its judgment in choosing the carrier and means of delivery. No deferment of shipment at Buyers' request beyond the respective dates indicated will be made except on terms that will indemnify, defend and hold Seller harmless against all loss and additional expense. Buyer shall be responsible for any additional shipping charges incurred by Seller due to Buyer's changes in shipping, product specifications or in accordance with Section 13, herein.
4. **Warranty.** Seller warrants that the Products sold hereunder shall be free from defects in material or workmanship for a period of eighteen months from the date of delivery to Buyer. The prices charged for Seller's products are based upon the exclusive limited warranty stated above, and upon the following disclaimer: **DISCLAIMER OF WARRANTY: THIS WARRANTY COMPRISES THE SOLE AND ENTIRE WARRANTY PERTAINING TO PRODUCTS PROVIDED HEREUNDER. SELLER DISCLAIMS ALL OTHER WARRANTIES, EXPRESS AND IMPLIED, INCLUDING MERCHANTABILITY AND FITNESS FOR A PARTICULAR PURPOSE.**
5. **Claims; Commencement of Actions.** Buyer shall promptly inspect all Products upon delivery. No claims for shortages will be allowed unless reported to the Seller within 10 days of delivery. No other claims against Seller will be allowed unless asserted in writing within 60 days after delivery or, in the case of an alleged breach of warranty, within 30 days after the date within the warranty period on which the defect is or should have been discovered by Buyer. Any action based upon breach of this agreement or upon any other claim arising out of this sale (other than an action by Seller for any amount due to Seller from Buyer) must be commenced within thirteen months from the date of tender of delivery by Seller or, for a cause of action based upon an alleged breach of warranty, within thirteen months from the date within the warranty period on which the defect is or should have been discovered by Buyer.
6. **LIMITATION OF LIABILITY. UPON NOTIFICATION, SELLER WILL, AT ITS OPTION, REPAIR OR REPLACE A DEFECTIVE PRODUCT, OR REFUND THE PURCHASE PRICE. IN NO EVENT SHALL SELLER BE LIABLE TO BUYER FOR ANY SPECIAL, INDIRECT, INCIDENTAL OR CONSEQUENTIAL DAMAGES ARISING OUT OF, OR AS THE RESULT OF, THE SALE, DELIVERY, NON-DELIVERY, SERVICING, USE OR LOSS OF USE OF THE PRODUCTS OR ANY PART THEREOF, OR FOR ANY CHARGES OR EXPENSES OF ANY NATURE INCURRED WITHOUT SELLER'S WRITTEN CONSENT, EVEN IF SELLER HAS BEEN NEGLIGENT, WHETHER IN CONTRACT, TORT OR OTHER LEGAL THEORY. IN NO EVENT SHALL SELLER'S LIABILITY UNDER ANY CLAIM MADE BY BUYER EXCEED THE PURCHASE PRICE OF THE PRODUCTS.**
7. **Contingencies.** Seller shall not be liable for any default or delay in performance if caused by circumstances beyond the reasonable control of Seller.
8. **User Responsibility.** The user, through its own analysis and testing, is solely responsible for making the final selection of the system and Product and assuring that all performance, endurance, maintenance, safety and warning requirements of the application are met. The user must analyze all aspects of the application and follow applicable industry standards and Product information. If Seller provides Product or system options, the user is responsible for determining that such data and specifications are suitable and sufficient for all applications and reasonably foreseeable uses of the Products or systems.
9. **Loss to Buyer's Property.** Any designs, tools, patterns, materials, drawings, confidential information or equipment furnished by Buyer or any other items which become Buyer's property, may be considered obsolete and may be destroyed by Seller after two consecutive years have elapsed without Buyer placing an order for the items which are manufactured using such property. Seller shall not be responsible for any loss or damage to such property while it is in Seller's possession or control.
10. **Special Tooling.** A tooling charge may be imposed for any special tooling, including without limitation, dies, fixtures, molds and patterns, acquired to manufacture Products. Such special tooling shall be and remain Seller's property notwithstanding payment of any charges by Buyer. In no event will Buyer acquire any interest in apparatus belonging to Seller which is utilized in the manufacture of the Products, even if such apparatus has been specially converted or adapted for such manufacture and notwithstanding any charges paid by Buyer. Unless otherwise agreed, Seller shall have the right to alter, discard or otherwise dispose of any special tooling or other property in its sole discretion at any time.
11. **Buyer's Obligation; Rights of Seller.** To secure payment of all sums due or otherwise, Seller shall retain a security interest in the goods delivered and this agreement shall be deemed a Security Agreement under the Uniform Commercial Code. Buyer authorizes Seller as its attorney to execute and file on Buyer's behalf all documents Seller deems necessary to perfect its security interest. Seller shall have a security interest in, and lien upon, any property of Buyer in Seller's possession as security for the payment of any amounts owed to Seller by Buyer.
12. **Improper Use and Indemnity.** Buyer shall indemnify, defend, and hold Seller harmless from any claim, liability, damages, lawsuits, and costs (including attorney fees), whether for personal injury, property damage, patent, trademark or copyright infringement or any other claim, brought by or incurred by Buyer, Buyer's employees, or any other person, arising out of: (a) improper selection, improper application or other misuse of Products purchased by Buyer from Seller; (b) any act or omission, negligent or otherwise, of Buyer; (c) Seller's use of patterns, plans, drawings, or specifications furnished by Buyer to manufacture Product; or (d) Buyer's failure to comply with these terms and conditions. Seller shall not indemnify Buyer under any circumstance except as otherwise provided.
13. **Cancellations and Changes.** Orders shall not be subject to cancellation or change by Buyer for any reason, except with Seller's written consent and upon terms that will indemnify, defend and hold Seller harmless against all direct, incidental and consequential loss or damage. Seller may change product features, specifications, designs and availability with notice to Buyer.
14. **Limitation on Assignment.** Buyer may not assign its rights or obligations under this agreement without the prior written consent of Seller.
15. **Entire Agreement.** This agreement contains the entire agreement between the Buyer and Seller and constitutes the final, complete and exclusive expression of the terms of the agreement. All prior or contemporaneous written or oral agreements or negotiations with respect to the subject matter are herein merged.
16. **Waiver and Severability.** Failure to enforce any provision of this agreement will not waive that provision nor will any such failure prejudice Seller's right to enforce that provision in the future. Invalidation of any provision of this agreement by legislation or other rule of law shall not invalidate any other provision herein. The remaining provisions of this agreement will remain in full force and effect.
17. **Termination.** This agreement may be terminated by Seller for any reason and at any time by giving Buyer thirty (30) days written notice of termination. In addition, Seller may by written notice immediately terminate this agreement for the following: (a) Buyer commits a breach of any provision of this agreement (b) the appointment of a trustee, receiver or custodian for all or any part of Buyer's property (c) the filing of a petition for relief in bankruptcy of the other Party on its own behalf, or by a third party (d) an assignment for the benefit of creditors, or (e) the dissolution or liquidation of the Buyer.
18. **Governing Law.** This agreement and the sale and delivery of all Products hereunder shall be deemed to have taken place in and shall be governed and construed in accordance with the laws of the State of Ohio, as applicable to contracts executed and wholly performed therein and without regard to conflicts of laws principles. Buyer irrevocably agrees and consents to the exclusive jurisdiction and venue of the courts of Cuyahoga County, Ohio with respect to any dispute, controversy or claim arising out of or relating to this agreement. Disputes between the parties shall not be settled by arbitration unless, after a dispute has arisen, both parties expressly agree in writing to arbitrate the dispute.
19. **Indemnity for Infringement of Intellectual Property Rights.** Seller shall have no liability for infringement of any patents, trademarks, copyrights, trade dress, trade secrets or similar rights except as provided in this Section. Seller will defend and indemnify Buyer against allegations of infringement of U.S. patents, U.S. trademarks, copyrights, trade dress and trade secrets ("Intellectual Property Rights"). Seller will defend at its expense and will pay the cost of any settlement or damages awarded in an action brought against Buyer based on an allegation that a Product sold pursuant to this Agreement infringes the Intellectual Property Rights of a third party. Seller's obligation to defend and indemnify Buyer is contingent on Buyer notifying Seller within ten (10) days after Buyer becomes aware of such allegations of infringement, and Seller having sole control over the defense of any allegations or actions including all negotiations for settlement or compromise. If a Product is subject to a claim that it infringes the Intellectual Property Rights of a third party, Seller may, at its sole expense and option, procure for Buyer the right to continue using the Product, replace or modify the Product so as to make it noninfringing, or offer to accept return of the Product and return the purchase price less a reasonable allowance for depreciation. Notwithstanding the foregoing, Seller shall have no liability for claims of infringement based on information provided by Buyer, or directed to Products delivered hereunder for which the designs are specified in whole or part by Buyer, or infringements resulting from the modification, combination or use in a system of any Product sold hereunder. The foregoing provisions of this Section shall constitute Seller's sole and exclusive liability and Buyer's sole and exclusive remedy for infringement of Intellectual Property Rights.
20. **Taxes.** Unless otherwise indicated, all prices and charges are exclusive of excise, sales, use, property, occupational or like taxes which may be imposed by any taxing authority upon the manufacture, sale or delivery of Products.
21. **Equal Opportunity Clause.** For the performance of government contracts and where dollar value of the Products exceed \$10,000, the equal employment opportunity clauses in Executive Order 11246, VEVRRA, and 41 C.F.R. §§ 60-1.4(a), 60-741.5(a), and 60-250.4, are hereby incorporated.



North America

Industrial

USA

Chicago Region

Naperville, IL
Tel: (630) 964 0796

Great Lakes Region

Fairlawn, OH
Tel: (330) 670 2680

Northeast Region

Lebanon, NJ
Tel: (908) 236 4121

Pacific Region

Buena Park, CA
Tel: (714) 228 2509

Southern Region

Alpharetta, GA
Tel: (770) 619 9767

Canada

Milton, Ontario
Tel: (905) 693 3000

México

Toluca, Edo. de México
Tel: (52) 72 2275 4200

Mobile

USA

Global Mobile

Lincolnshire, IL
Tel: (847) 821 1500

Central Region

Lincolnshire, IL
Tel: (847) 821 1500

Eastern Region

North Canton, OH
Tel: (330) 284 3355

Midwest Region

Hiawatha, IA
Tel: (319) 393 1221

Southern Region

Aledo, TX
Tel: (817) 441 1794

Western Region

Buena Park, CA
Tel: (714) 228 2509

Canada

Milton, Ontario
Tel: (905) 693 3000

México

Apodaca, N.L.
Tel: (52) 81 8156 6000

Truck

USA

Eastern Region

Cleveland, OH
Tel: (440) 519 1125

Western Region

San Ramon, CA
Tel: (925) 735 9573

Canada

Milton, Ontario
Tel: (905) 693 3000

México

Apodaca, N.L.
Tel: (52) 81 8156 6000

Europe

Austria

Wiener Neustadt
Tel: (43) 2622 23501 0

Belgium

Nivelles
Tel: (32) 67 280 900

Czech Republic and Slovakia

Klecany
Tel: (420) 284 083 111

Denmark

Ballerup
Tel: (45) 4356 0400

Finland

Vantaa
Tel: (358) 20 753 2500

France

Contamine-sur-Arve
Tel: (33) 4 50 25 80 25

Germany

Kaarst
Tel: (49) 2131 4016 0

Greece

Athens
Tel: (30) 210 933 6450

Hungary

Budapest
Tel: (36) 1 220 4155

Ireland

County Dublin, Baldonnell
Tel: (353) 1 466 6370

Italy

Corsico, Milano
Tel: (39) 02 45 19 21

The Netherlands

Oldenzaal
Tel: (31) 541 585000

Norway

Ski
Tel: (47) 64 91 10 00

Poland

Warsaw
Tel: (48) 22 57 32400

Portugal

Leca da Palmeira
Tel: (351) 22 999 7360

Romania

Bucharest
Tel: (40) 21 252 1382

Russia

Moscow
Tel: (7) 495 580 9145

Slovenia

Novo Mesto
Tel: (386) 7 337 6650

Spain

Madrid
Tel: (34) 91 675 7300

Sweden

Spanga
Tel: (46) 8 597 95000

Ukraine

Kiev
Tel: (380) 44 494 2731

United Kingdom

Warwick,
Tel: (44) 1926 317878

Asia Pacific

Australia

Castle Hill
Tel: (61) 2 9634 7777

China

Beijing
Tel: (86) 10 6561 0520

Shanghai

Tel: (86) 21 5031 2525

Hong Kong

Tel: (852) 2428 8008

India

Mahape, Navi Mumbai
Tel: (91) 22 5613 7081

Korea

Seoul
Tel: (82) 2 559 0400

Malaysia

Subang Jaya
Tel: (60) 3 5638 1476

New Zealand

Mt. Wellington
Tel: (64) 9 574 1744

Japan

Tokyo
Tel: (81) 3 6408 3900

Singapore

Jurong Town
Tel: (65) 6 887 6300

Taiwan

Taipei
Tel: (886) 2 2298 8987

Thailand

Bangkok
Tel: (662) 717 8140

Middle East

United Arab Emirates

Abu Dhabi
Tel: (971) 2 678 8587

Latin America

Pan American Division

Miami, FL
Tel: (305) 470 8800

Argentina

Buenos Aires
Tel: (54) 33 2744 4129

Brazil

Cachoeirinha RS
Tel: (55) 51 3470 9144

Venezuela

Caracas
Tel: (58) 212 238 5422

Africa

South Africa

Kempton Park
Tel: (27) 11 961 0700

