



aerospace
climate control
electromechanical
filtration
fluid & gas handling
hydraulics
pneumatics
process control
sealing & shielding



Industrial Hose Couplings

Catalogue



ENGINEERING YOUR SUCCESS.

Parker Hose Products

A short summary of a long history

Parker Hose Products Division, established in 1948, is both a pioneer and market leader in the hose business.

With its history of success as a world leader in the flexible rubber hose market, Parker now more than ever continues to pursue aggressively new technologies and business, and because of this, offers its customers the best solution for each and every hose application.

Parker has built strong relationship at the OEM and aftermarket levels, tailoring its products and services to the special requirements of both markets.

Parker's goal is constant success. Cooperation with our customers brings about confidence and reliability, mutual respect, open communication and prompt and problem-solving responses.

Hose Products Division Europe has its headquarters in Veniano, Italy, and can supply the hoses and services you need for your particular business.

Customer Focused

Hose Products Division Europe is customer focused and serving European markets with hydraulic and industrial hose products and services.

By maximising value for our customers through quality and service, we can contribute to their and our own long-term profitability. As an easy-to-deal-with organization, we see the empowerment of everyone involved as the key success factor in remaining the preferred source for our markets.



Industrial Hoses and Couplings

Long length hoses, mandrel-made hoses, PVC-PU hoses and Couplings

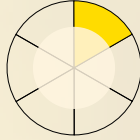
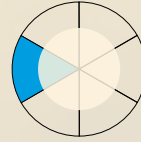

Hydraulic Hoses

Low pressure, medium pressure and high pressure braided and spiral hoses

Hydraulic Fittings

Permanent crimp fittings and re-usable fittings

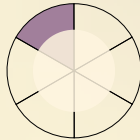
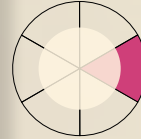

Hose and Tube Assemblies

Hose assemblies, rigid tubes, hose/tube combinations, Tech. Services, Kanban, Kitting

Mining Products

Mining hoses, adaptors, valves, filters, pipelines, couplings, manifolds

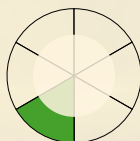
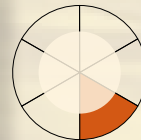

Rubber Compounds

Standard compounds and customer specific formulations. All compounds available in black and coloured

A giant step

into the industrial hose world

Parker industrial hoses, formerly sold under the ITR brand name, have given excellent service and quality to our customers for more than a century. With its history of success in the industrial hose business, Parker now more than ever continues to pursue aggressively new technologies and business, and because of this offers our customers the best solution for each and every hose application.

Industrial hose production

The Parker industrial hose production unit has long-standing experience in the manufacture and supply of high quality industrial hoses that meet the demands of today's market.

Ecology

Caring for and ensuring the sustainability of the planet is our intention; we therefore develop and improve hoses for alternative fuels like gas, natural oils, ester oils etc. for environmentally-friendly technologies such as the new SCR one. Parker developed nitrosamine-free compounds to improve the quality of life and of the environment.

Improvement

Furthermore we constantly update the performance of our Parker industrial hoses to help you work smarter, faster, and better. A high abrasion resistance hose with an inner tube made of ceramic hexagonal plates is one of our latest developments for ultra-high abrasion resistance.

Brand promise

Parker is the global leader in motion and control technologies, partnering with its customers to improve their productivity and profitability. It is not just a slogan, but the expression of our commitment to our customers. Partnership with a strong network of certified distributors enables market needs and evolution to be fully understood and served.

Market segments for industrial hoses:

- Industrial and Mobile
- Petrochemical
- Construction and Building
- Shipyards
- Agriculture
- Food and Beverage
- Mining
- Pulp and Paper
- Automotive

Parker is a company which operates in compliance with the quality system laid down by the UNI EN ISO 9001 standard, certified by Det Norske Veritas.

More and more Parker industrial hoses are certified by the main international certification bodies such as: RINA, Cerisie, DNV, TÜV Rheinland, Lloyd's Register etc.



Rubber and PVC-PU Hoses

for industrial applications

Parker strives to launch new and innovative hoses designed to meet all your material transfer requirements. Our complete line of RUBBER and PVC-PU hoses, combined with industry-leading technical training, customer service, field sales support and a distribution network can help and assist you in getting the right product for your application.



Our product range includes industrial hoses for conveying materials such as water, steam, air, abrasive products, chemical media, fuels and mineral oils, technical and domestic gases, etc.

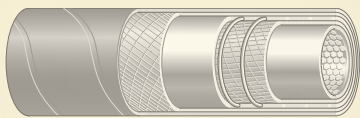

Specially designed hoses for dedicated applications such as petrochemical or aviation are manufactured with premium quality NBR and chloroprene compounds to limit the risk of fluid contamination and to prolong hose service life. Corrugated hoses are also available to give better performance in terms of flexibility and easy handling.

Nitrosamine-free compound hoses represent the real news in Parker's industrial hose programme - they improve both environmental conditions and the quality of life.

The continuous development of Parker products is the best guarantee of premium quality hoses.

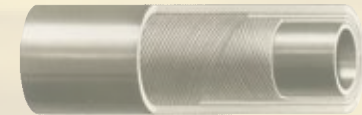
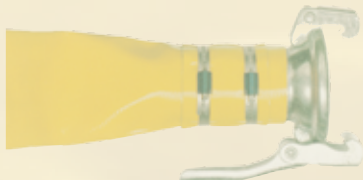

General Information	x
Kamlock	a
Thread Couplings (BSP)	b
European Air Couplings	c
GK Couplings	d
Tankwagen	e
Guillemin	f
Petrol Pump	g
Flange	h
Steam	i
Sandblast Couplings	j
Mortar Couplings	k
Cardan	l
Food DIN / SMS	m
Safety Clamps	n
Bolt Clamps	o
Worm Clamps	p
Crimp Fittings	q

Index

Materials	x3–x4
Corrosion Resistance of Coupling Materials	x5–x8
Properties of Basic Rubber Compounds	x9
Rubber Hose Construction	x10
Determining Sealing Mechanisms	x11
Determining Thread Type	x12
European Thread Types – German DIN Hose Fittings	x13–x14
European Thread Types – British Standard Pipe (BSP)	x15
Flanges Code 61	x16
Hose and Fittings Terminology	x17–x19
Routing / Installation	x20–x21
Hose Assemblies	x22–x23
Hose Assemblies with Safety-Clamps	x24
Hose Assemblies with Reusable Fittings	x25
Hose Assemblies with Bolt/Worm Clamps	x26
Hose Assemblies with Crimp Fittings	x27
Conversion Chart	x28
Temperature / Pressure Chart	x29
Flow Capacity Chart	x30
Safety First	x31
Safety Warnings	x32–x33

Materials

STEEL

Iron, like most metals, is not usually found in the Earth's crust in an elemental state and is extracted from ore by removing the oxygen by combining it with a preferred chemical partner such as carbon. This process, known as smelting, should take place in a low-oxygen environment. When iron is smelted from its ore by commercial processes, it contains more carbon than is desirable. To become steel, it must be melted and reprocessed to remove the correct amount of carbon, other materials are often added to the iron/carbon mixture to tailor the resulting properties. Modern steels are made with varying combinations of alloy metals to fulfill many purposes. Carbon steel, composed simply of iron and carbon, accounts for 90% of steel production.[1] High strength low alloy steel has small additions (usually < 2% by weight) of other elements, typically 1.5% manganese, to provide additional strength for a modest price increase. Low alloy steel is alloyed with other elements, usually molybdenum, manganese, chromium, or nickel, in amounts of up to 10% by weight to improve the hardenability of thick sections. Most of the more commonly used steel alloys are categorized into various grades by standards organizations. Usual steel, if in contact with water and oxygen, will rust - the so called "oxidation of iron metals". To prevent steel from rusting, zinc coatings are applied.

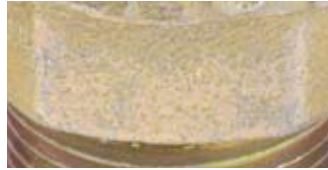

STAINLESS STEEL

In metallurgy, stainless steel is defined as an iron-carbon alloy with a minimum of 11.5 wt% chromium content. Stainless steel does not stain, corrode or rust as easily as ordinary steel (it "stains less"), but it is not stain-proof. It is also called corrosion resistant steel when the alloy type and grade are not detailed, particularly in the aviation industry. There are different grades and surface finishes of stainless steel to suit the environment to which the material will be subjected in its lifetime. High oxidation-resistance in air at ambient temperature is normally achieved with additions of a minimum of 13% (by weight) chromium, and up to 26% is used for harsh environments. The chromium forms a passivation layer of chromium oxide when exposed to oxygen. The layer is too thin to be visible, which means that the metal remains lustrous. It is, however, impervious to water and air, protecting the metal beneath. Also, this layer quickly reforms when the surface is scratched. This phenomenon is called passivation and is seen in other metals, such as aluminum and titanium. When stainless steel parts such as nuts and bolts are forced together, the oxide layer can be scraped off causing the parts to weld together. When disassembled, the welded material may be torn and pitted, an effect that is known as galling. This destructive galling can be best avoided by the use of dissimilar materials, e.g. bronze to stainless steel, or even different types of stainless steels, when metal-to-metal wear is a concern. Nickel also contributes to passivation, as do other less commonly used ingredients such as molybdenum and vanadium. The proportions of iron to chromium may be varied and other elements such as nickel, molybdenum, manganese and nitrogen may be added to widen the range of capabilities. Each particular grade of stainless steel has its own unique mechanical and physical properties and will usually be produced in accordance with an established national or international specification or standard.



ZINC COATINGS

Zinc coatings prevent corrosion of the protected metal by forming a physical barrier, and by acting as a sacrificial anode if this barrier is damaged. When exposed to the atmosphere, zinc reacts with oxygen to form zinc oxide, which further reacts with water molecules in the air to form zinc hydroxide. Finally zinc hydroxide reacts with carbon dioxide in the atmosphere to yield a thin, impermeable, tenacious and quite insoluble dull grey layer of zinc carbonate which adheres extremely well to the underlying zinc, so protecting it from further corrosion, in a way similar to the protection afforded to aluminum and stainless steels by their oxide layers.

Materials

ALUMINUM

Aluminum is a soft, lightweight, malleable metal with appearance ranging from silvery to dull gray, depending on the surface roughness.



Aluminum is nontoxic, nonmagnetic, and nonsparking. It is also insoluble in alcohol, though it can be soluble in water only in certain forms. The yield strength of pure aluminum is 7–11 MPa, while aluminum alloys have yield strengths ranging from 200 MPa to 600 MPa. Aluminum has about one-third the density and stiffness of steel. It is ductile, and easily machined, cast, and extruded. Corrosion resistance is excellent due to a thin surface layer of aluminum oxide that forms when the metal is exposed to air, effectively preventing further oxidation. Aluminium is also a very good conductor of electricity, which, in combination with its other intrinsic qualities, has ensured its use as a replacement for copper in many applications. Other valuable properties include high reflectivity, heat barrier properties and heat conduction. The metal is malleable and easily worked using all the usual manufacturing and shaping processes.

POLYPROPYLENE

Polypropylene is an economical material that offers a combination of outstanding physical, chemical, mechanical, thermal and electrical



properties not found in any other thermoplastic. Compared with low- and high-density polyethylene, it has lower impact strength, but superior working temperature and tensile strength. Polypropylene offers excellent resistance to organic solvents, degreasing agents and electrolytic attack. It is light in weight, stain-resistant and has a low moisture absorption rate. Polypropylene is a tough, heat-resistant, semi-rigid material, ideal for the transfer of hot liquids or gases. It is recommended for vacuum systems and wherever high temperatures and pressures are likely to be encountered. It offers excellent resistance to acids and alkalis, but performs poorly with aromatic, aliphatic and chlorinated solvents.

BRASS

Brass has a muted yellow color, somewhat similar to gold and is any alloy of copper and zinc; the proportions of zinc and copper can



be varied to create a range of brasses with varying properties. In comparison, bronze is principally an alloy of copper and tin. Despite this distinction, some types of brasses are called bronzes. Brass is a substitutional alloy. It is used for decoration for its bright gold-like appearance; for applications where low friction is required such as locks, gears, bearings, ammunition, couplings and valves; for plumbing and electrical applications; and extensively in musical instruments such as horns and bells for its acoustic properties. It is relatively resistant to tarnishing, and has higher malleability than copper or zinc. The relatively low melting point of brass (900 to 940°C, depending on composition) and its flow characteristics make it a relatively easy material to cast. By varying the proportions of copper and zinc, the properties of the brass can be changed, allowing hard and soft brasses. For example aluminum makes brass stronger and more corrosion resistant and also causes a highly beneficial hard layer of aluminum oxide to be formed on the surface that is thin, transparent and self healing. Tin has a similar effect and finds its use especially in sea water applications (naval brasses). Combinations of iron, aluminum, silicon and manganese make brass wear and tear resistant and a combination of manganese and silicon leads to a strong and resistant brass.

Corrosion Resistance of Coupling Materials

CAUTION: The following data has been compiled from generally available sources and should not be relied upon without consulting and following the specific recommendations of the manufacturer regarding particular coupling materials.

X

Chemical or Material Conveyed	Brass	Aluminium	Stainless Steel 410, 416, 430	Stainless Steel 302, 202, 304, 308	Stainless Steel 316
Acetate, Solvents, Crude	3		2	1	1
Acetate, Solvents, Pure	1	1	1	1	1
Acetic Acid	X	2	X	2	2
Acetic Acid Vapors	X	3	X	2	2
Acetic Anhydride	X	2	X	2	2
Acetone	1	1	1	1	1
Acetylene	2	1	1	1	1
Alcohols	2	1	1	1	1
Aluminum Sulfate	3	3	X	3	2
Alums	3	3	X	3	2
Ammonia Gas	X	1	1	1	1
Ammonium Chloride	3	1*	3	3	1
Ammonium Hydroxide	X	2	1	1	1
Ammonium Nitrate	X	2	1	1	1
Ammonium Phosphate (Ammoniacal)	X			1	1
Ammonium Phosphate (Neutral)	3		1	1	1
Ammonium Phosphate (Acid)	3		3	2	1
Ammonium Sulfate	3		2	1	1
Asphalt	2		2	1	1
Beer	2	1	X	1	1
Beet Sugar Liquors	2	1	2	1	1
Benzene, Benzol	1	1	1	1	1
Benzine (petroleum –naphtha)	1	1	1	1	1
Borax	2		1	1	1
Boric Acid	3	1	3	2	1
Butane, Butylene	1	1	1	1	1
Butadiene	1		1	1	1
Calcium Bisulfate	X		X	2	1
Calcium Hypochlorite	3	X	X	3	2
Cane Sugar Liquors	2	1	2	1	1
Carbon Dioxide (Dry)	1	1	1	1	1
Carbon Dioxide (Wet & Aqueous Sol)	3	2	2	1	1
Carbon Disulfide	3	2	2	1	1
Carbon Tetrachloride	1	3	1	1	1
Chlorine (Dry)	2	1	2	2	2

KEY: 1 = Excellent, 2 = Good, 3 = Fair or Conditional, X = NOT Satisfactory, *3 to X at high temperatures

NOTE: No rating indicates no data available

General Information
Corrosion Resistance of Coupling Materials

Chemical or Material Conveyed	Brass	Aluminium	Stainless Steel 410, 416, 430	Stainless Steel 302, 202, 304, 308	Stainless Steel 316
Chlorine (Wet)	X	X	X	X	3
Chromic Acid	X	X	3	2	2
Citric Acid	3	1	3	X	1
Coke Oven Gas	3	2	1	1	1
Copper Sulfate	X	X	1	1	1
Core Oils	1		1	1	1
Cottonseed Oil	1	1		1	1
Creosote	3	1	1	1	1
Ethers	1	1	1	1	1
Ethylene Glycol	2		1	1	1
Ferric Chloride	X	X	X	X	X
Ferric Sulfate	X	X	1	1	1
Formaldehyde	2	2	1	1	1
Formic Acid	2	X	X	2	1
Freon	1	1	1	1	1
Furfural	2	1	1	1	1
Gasoline (Sour)	3	3	3	1	1
Gasoline (Refined)	1	1	1	1	1
Gelatin	3	1	1	1	1
Glucose	1	1	1	1	1
Glue	3	1	1	1	1
Glycerine or Glycerol	2	1	1	1	1
Hydrochloric Acid	X	X	X	X	X
Hydrocyanic Acid	X	1	3	1	1
Hydrofluoric Acid	3	X	X	X	X
Hydrogen Fluoride	3		X	X	3
Hydrogen	1	1	1	1	1
Hydrogen Peroxide	X	1	1	2	1
Hydrogen Sulfide (Dry)	3	2	3	2	1
Hydrogen Sulfide (Wet)	3	2	3	2	1
Lacquers and Lacquer Solvents	2	1	1	1	1
Lactic Acid		3		3	2
Lime Sulfur	X	2	1	1	2
Linseed Oil	1	1		1	1
Magnesium Chloride	3	X	3	2	1
Magnesium Hydroxide	2	X	1	1	1
Magnesium Sulfate	2	3	1	1	1
Mercuric Chloride	X	X	X	X	3
Mercury	X	X	1	1	1
Milk	3	1	2	1	1

KEY: 1 = Excellent, 2 = Good, 3 = Fair or Conditional, X = NOT Satisfactory, *3 to X at high temperatures

NOTE: No rating indicates no data available

Chemical or Material Conveyed	Brass	Aluminium	Stainless Steel 410, 416, 430	Stainless Steel 302, 202, 304, 308	Stainless Steel 316
Molasses	X	2	2	1	1
Natural Gas	2	1	1	1	1
Nickel Chloride	X	X	X	3	2
Nickel Sulfate	3	X	3	2	1
Nitric Acid	X	3	2	2	2
Oleic Acid	3	1	2	2	1
Oxalic Acid	3	2	3	2	1
Oxygen	1	1		1	1
Palmitic Acid	3	1	2	2	1
Petroleum Oils (Sour)	3		3	1	1
Petroleum Oils (Refined)	1	1	1	1	1
Phosphoric Acid 25%	X	3	3	X	3
Phosphoric Acid 25%–50%	X	X	3	X	X
Phosphoric Acid 50%–85%	X	X	X	X	X
Picric Acid	X	3	2	1	1
Potassium Chloride	3	3	3	2	1
Potassium Hydroxide	X	X	1	1	1
Potassium Sulfate	2	1	1	1	1
Propane	1		1	1	1
Rosin (Dark)	2		1	1	1
Rosin (Light)	X	1	1	1	1
Shellac	2	2	1	1	1
Sludge Acid	X		X	X	3
Soda Ash (Sodium Carbonate)	2	X	1	1	1
Sodium Bicarbonate	1	X	1	1	1
Sodium Bisulfate	3	3	X	1	1
Sodium Chloride	3	X	3	2	1
Sodium Cyanide	X	X	1	1	1
Sodium Hydroxide	X	X	2	2	2
Sodium Hypochlorite	X	X	X	3	2
Sodium Metaphosphate	3	1	2	1	1
Sodium Nitrate	3	1	1	1	1
Sodium Perborate	3	1	1	1	1
Sodium Peroxide	3	1	1	1	1
Sodium Phosphate –Alkaline	3		1	1	1
Sodium Phosphate – Neutral	2		1	1	1
Sodium Phosphate – Acid	2		X	2	1
Sodium Silicate	3	X	1	1	1
Sodium Sulfate	2	3	1	1	1
Sodium Sulfide	X		1	1	1

KEY: 1 = Excellent, 2 = Good, 3 = Fair or Conditional, X = NOT Satisfactory, *3 to X at high temperatures

NOTE: No rating indicates no data available

General Information
Corrosion Resistance of Coupling Materials

Chemical or Material Conveyed	Brass	Aluminium	Stainless Steel 410, 416, 430	Stainless Steel 302, 202, 304, 308	Stainless Steel 316
Sodium Thiosulfate (Hypo)	X	X	1	1	1
Stearic Acid	3	3	2	2	1
Sulfate Liquors	X		1	1	1
Sulfur	X	2	2	2	1
Sulfur Chloride	X		X	3	2
Sulfur Dioxide (Dry)	1	1	1	1	1
Sulfur Dioxide (Wet)	X		X	2	1
Sulfuric Acid 10%	X	3	X	X	2
Sulfuric Acid 10%-75%	X	X	X	X	X
Sulfuric Acid 75%-95%	X	X	3	3	2
Sulfuric Acid — 95%	X		2	2	2
Sulfurous Acid	X	X	X	3	2
Tannic Acid	3	X	1	1	1
Tar	2	1	2	1	1
Toluene, Toluol	1	1	1	1	1
Trichlorethylene	1	3	1	1	1
Turpentine	3	1	3	1	1
Varnish	2		1	1	1
Vegetable Oils	2	1	1	1	1
Vinegar	3	3	3	2	1
Water (Acid Mine Water)	X	3	2	1	1
Water (Fresh)	1	1	1	1	1
Water (Salt)	3	X	3	2	2
Whiskey	2		3	1	1
Wines	2		3	1	1
Xylene, Xylol	1	1	1	1	1
Zinc Chloride	X	X	3	2	1
Zinc Sulfate	3	3	3	2	1

KEY: 1 = Excellent, 2 = Good, 3 = Fair or Conditional, X = NOT Satisfactory, *3 to X at high temperatures

NOTE: No rating indicates no data available

Properties of Basic Rubber Compounds

This table provides some information on the general properties of the most common rubber compounds. Most compounds used in the manufacture of rubber hose are made of different basic rubbers, each contributing to the physical properties of the finished product.

ASTM D 1418	Chemical Name	Properties
CR	Chloroprene	<i>Excellent weathering and ozone resistance, flame retarding, abrasion resistance. Good resistance to compressed air and to oil.</i>
CSM	Chloro-sulfonyl-polyethylene	<i>Excellent resistance to ozone, weathering and acid, particularly of the coloured compounds. Resistant to petroleum based fluids.</i>
EPDM	Terpolymer of ethylene-propylene-diene	<i>Good resistance to heat, ageing and abrasion. Poor resistance to petroleum based fluids.</i>
EPM	Copolymers of ethylene and propylene	<i>Excellent resistance to heat, ageing, abrasion and ozone. Good resistance to many chemicals; poor resistance to aromatics.</i>
FKM	Fluorine rubber	<i>Excellent resistance to a wide range of chemicals and to heat. Poor physical properties.</i>
IIR	Isobutene-isoprene	<i>Good resistance to chemicals, such as alcohols, ketones and esters.</i>
NBR	Acrylonitrile-butadiene	<i>Excellent oil resistance good aromatics and solvents resistance.</i>
NR	Natural rubber	<i>Good physical properties including abrasion and low temperature resistance. Poor resistance to petroleum based fluids.</i>
SBR	Styrene-butadiene	<i>Good physical properties with resistance to heat and abrasion. Poor resistance to petroleum based fluids.</i>
NBR/PVC	Acrylonitrile-butadiene-vynil-chloride	<i>Good resistance to oil and aromatics. Recommended as hose cover, when a good weathering, ozone and abrasion resistance is required.</i>
UHMWPE	Ultra high molecular weight polyethylene	<i>Excellent abrasion resistance and very low coefficient of friction. Excellent resistance to chemicals, oil and aromatic fuels. Biologically inert and suitable for foodstuffs delivery.</i>

Rubber Hose Construction



TUBE

It is the innermost rubber or plastic element of the hose. Must be resistant to the materials it is intended to convey. The characteristics of the rubber or plastic compound and the thickness of the tube depend on the service in which the hose will be used.

REINFORCEMENT

Can be textile, plastic or metal, alone or in combination, built into the body of the hose to withstand internal pressures, external forces or combination of both.

COVER

It is the outer element and can be made of rubber, plastic or textile materials. The function of the cover is to protect the hose from damage and environment.



LONG LENGTH (LL)

Production method:

Seamless extruded hoses without or on flexible mandrel and eventually white lead vulcanization with synthetic textile yarn reinforcement for standard production up to 100 m and internal diameter up to I.D. 35 mm.



MANDREL MADE (MM)

Production method:

Hose produced on a rigid mandrel with a reinforcement of textile fabrics or steel braids, with or without steel wire helix, for standard production length up to 40 m and internal diameter range from I.D. 19 mm to I.D. 250 mm.



Identifying Fitting Types

In general fittings can be identified by their visual appearance, their sealing surface/ sealing type or by their thread type/form. Viewing the following pages the visual identification will be self explanatory. The sealing mechanism and the method of thread identification however, needs further explanation

Determining Sealing Mechanisms:

- Thread interface
- O-ring
- Matching angle or metal to metal joint
- Mated angle with O-ring

Thread Interface

The sealing is assured by the flattening of the edges of the threads when the male is screwed into the female fitting. Typically the front of the male fittings are narrower than the back of the fittings – often referred to as tapered threads.

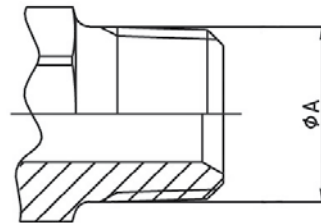

O-ring

The O-ring on the male is compressed against the corresponding female and assures the seal. This type of sealing mechanism should be the preferred choice for high-pressure applications.

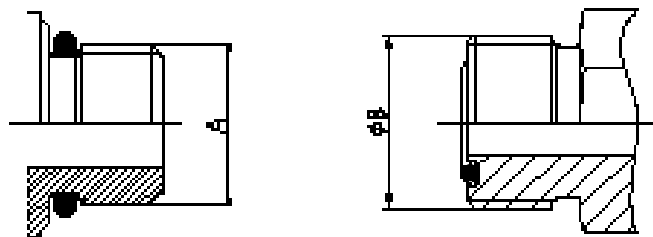

Matching Angle or Metal to Metal Joint

The seal takes place where the two angled faces of the male and corresponding female meet and are wedged into one another by the tightening of the threaded nut.

The sealing surfaces can either be convex or concave (seat) on the male or in the head of the pipe of the female as shown.

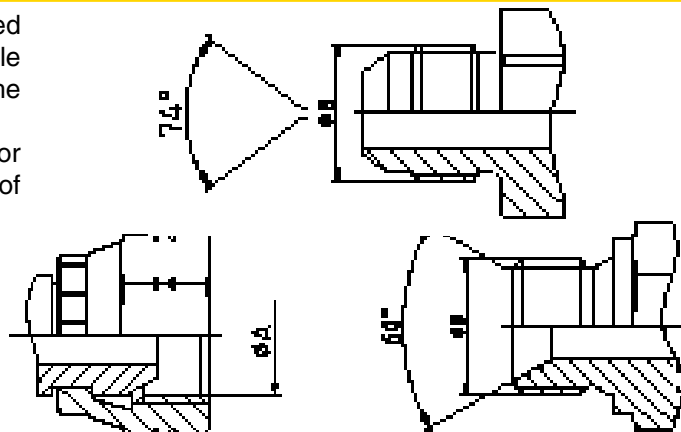

Matching Angle with O-ring

These fittings combine the functionality of both the matching angle seal with the O-ring. The O-ring is in the angled sealing surface of the fitting so that when the threaded male and female are screwed together the sealing surfaces wedge together and at the same time deform the O-ring between them.

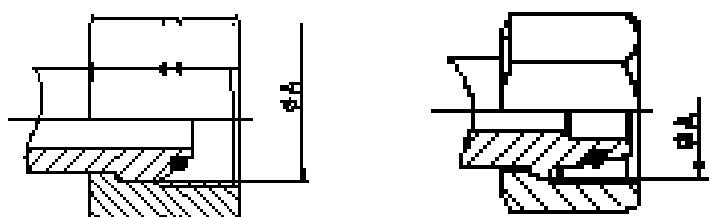

Determining Thread Type

In general the appearance of the threads of various fittings looks similar and hinders the easy identification of the thread. To assure the correct identification, the threads must be measured and compared to the tables listed in the following section.

Thread Gauge

Using a thread gauge, the number of threads per inch can be determined. Holding the gauge and coupling threads in front of a lighted background helps to obtain an accurate measurement.



Caliper Measure

A vernier caliper should be used to measure the thread diameter of the largest point. (Outside diameter (O.D.) of male threads – Inside Diameter (I.D.) of female threads.)

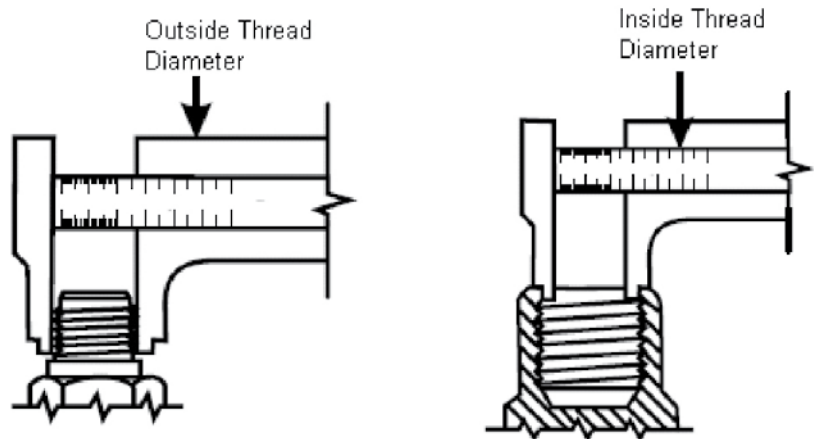



German DIN Hose Fittings (DIN – Deutsches Institut für Normung)

Often referred to as metric fittings these fittings seal using the angled sealing surfaces (metal to metal) or the combination of metal to metal with O-rings.

They are available in **very light (LL)**, **light series (L)** or **heavy series (S)**

The sealing face angles are either 24° with or without O-rings, or 24°/60° universal cones.

Identification is made by measuring the thread size and also the tube outside diameter.

Defined by the outside diameter and the pitch
(distance between 2 crests of the thread)
example: M22x1.5 - pitch of 1,5mm

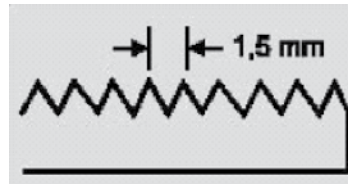

DIN Very Light Series (LL)

The male 60° cone will mate with the female 60° cone only.
The male has a 60° sealing angle (seat) and straight metric thread. The female has a 60° seat and straight metric thread.

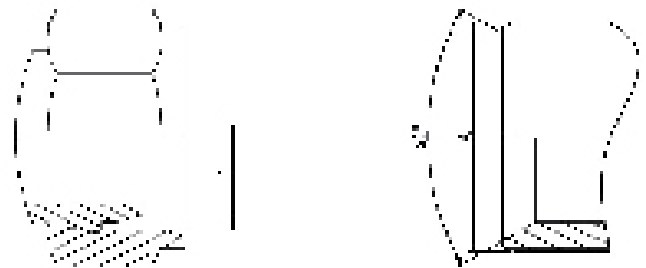

Standard
DIN 20078 Part 3 ¹⁾

Parker end configurations
C0

DN	Metric thread	ØA (mm)	ØB (mm)
20	M30x1.5	30,00	28,50
25	M38x1.5	38,00	36,50
32	M45x1.5	45,00	43,50
40	M52x1.5	52,00	50,50
50	M65x2	65,00	63,00

DIN Light (L) and Heavy Series (S) without O-ring

The male 60° cone will mate with the female universal 24° or 60° cone only.
The male has a 60° sealing angle (seat) and straight metric threads. The female has a 24° and 60° universal seat and straight metric threads.

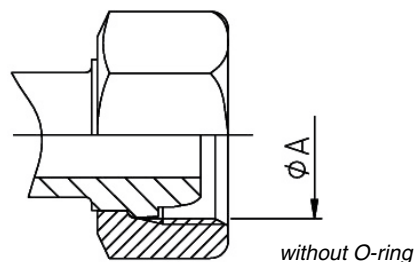

Standard
DIN 20078 Part 2 ¹⁾
(previously known as DIN 20078 A, D & E)

Parker end configurations light series:
C3, C4, C5, C6

(Often also referred to as “Ball nose cones”)

¹⁾ obsolete standard, no exact replacement

**DIN 24° Light (L) and Heavy Series (S)
 with O-ring**

The male has a 24° sealing angle cone seat with straight metric threads.

The female has a 24° convex cone with O-ring and a swivel straight metric threaded nut.

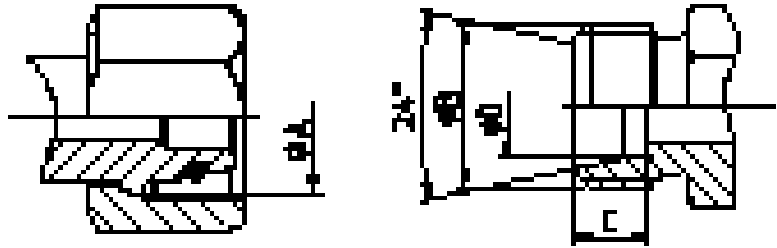

with O-ring

Standard

ISO 12151-2 / ISO 8434-1 & ISO 8434-4

(Previously DIN 20 078 Part 4, 5, 8, 9)

Parker end configurations light series

CA, CE, CF, D0

Parker end configurations heavy series

C9, 0C, 1C, D2

Tube OD	Specif.	Metric thread	ØA (mm)	ØB (mm)	C (mm)	ØD (mm)
6,00	6L	M12X1.5	10,50	12,00	7,00	6,20
6,00	6S	M14X1.5	12,50	14,00	7,00	6,20
8,00	8L	M14x1.5	12,50	14,00	7,00	8,20
8,00	8S	M16x1.5	14,50	16,00	7,00	8,20
10,00	10L	M16x1.5	14,50	16,00	7,00	10,20
10,00	10S	M18x1.5	16,50	18,00	7,50	10,20
12,00	12L	M18x1.5	16,50	18,00	7,00	12,20
12,00	12S	M20x1.5	18,50	20,00	7,50	12,20
14,00	14S	M22x1.5	20,50	22,00	8,00	14,20
15,00	15L	M22x1.5	20,50	22,00	7,00	15,20
16,00	16S	M24x1.5	22,50	24,00	8,50	16,20
18,00	18L	M26x1.5	24,50	26,00	7,50	18,20
20,00	20S	M30x2	27,90	30,00	10,50	20,20
22,00	22L	M30x2	27,90	30,00	7,50	22,20
25,00	25S	M36x2	33,90	36,00	12,00	25,20
28,00	28L	M36x2	33,90	36,00	7,50	28,20
30,00	30S	M42x2	39,90	42,00	13,50	30,20
35,00	35L	M45x2	42,90	45,00	10,50	35,30
38,00	38S	M52x2	49,90	52,00	16,00	38,30
42,00	42L	M52x2	49,90	52,00	11,00	42,30



British Standard Pipe (BSP)

Also referred to as Whitworth threads, the BSP thread type fittings seal using metal to metal angled surfaces or a combination of metal to metal and an O-ring.

The angle of the sealing surfaces is 60° for both forms.

There are two popular thread forms, British Standard Pipe Parallel (BSPP) and British Standard Pipe Tapered (BSPT).

Identification is made by measuring the outside diameter of the thread and the number of threads per inch (25.4 mm)

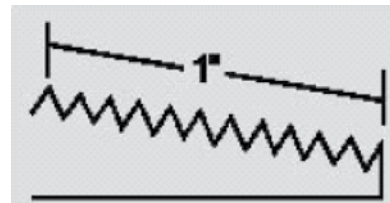

BSPP

metal to metal without O-r.

Standard
BS5200

Parker end configurations
92, B1, B2, B4, D9

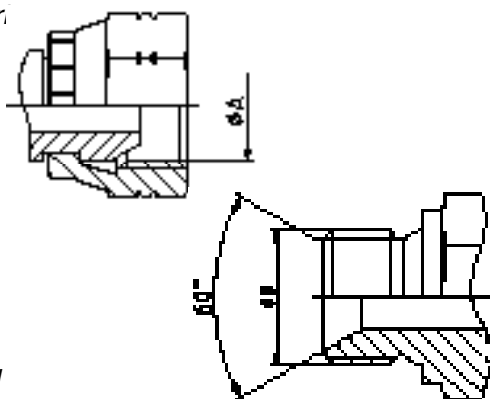

Tube OD	Size	BSP Thread	OA (mm)	OB (mm)
6/10	-2	1/8-28	8,60	9,70
8/13	-4	1/4-19	11,50	13,20
12/17	-6	3/8-19	14,90	16,70
15/21	-8	1/2-14	18,60	20,90
18/23	-10	5/8-14	20,60	22,90
20/27	-12	3/4-14	24,10	26,40
26/34	-16	1"-11	30,30	33,20
33/42	-20	1.1/4-11	38,90	41,90
40/49	-24	1.1/2-11	44,90	47,80
50/60	-32	2-11	56,70	59,60

BSPP

metal to metal with O-ring

Standard
ISO 12151-6 ²⁾

Parker end configurations
EA, EB, EC, EE, D9

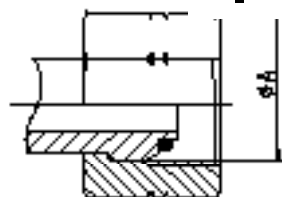

BSPT

fittings seal through the thread interface mechanism. Care should be taken not to confuse the BSPT fitting with the NPTF male fitting. BSPT has a 55° thread angle. NPTF has 60° thread angle.

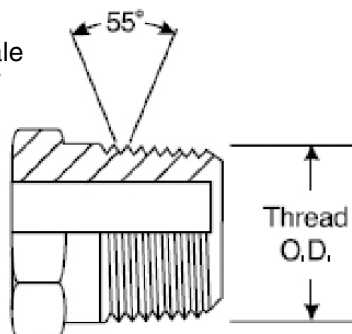

Tube size	size	BSP Thread	OA (mm)
5/10	-2	1/8-28	9,73
8/13	-4	1/4-19	13,16
12/17	-6	3/8-19	16,66
15/21	-8	1/2-14	20,96
20/27	-12	3/4-14	26,44
26/34	-16	1"-11	33,25
33/42	-20	1.1/4-11	41,91
40/49	-24	1.1/2-11	47,80
50/60	-32	2-11	59,61

Parker end configuration
91

BSP Flat Seal

These fittings have BSP parallel threads but the sealing surface is flat. The seal is made when the composite seal is compressed against the female flat face.

Parker end configurations
B5, B6, B7

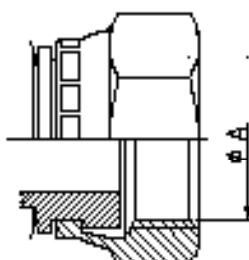

Tube OD	Size	BSP thread	OA (mm)
6/10	-2	1/8-28	8,6
8/13	-4	1/4-19	11,5
12/17	-6	3/8-19	14,9
15/21	-8	1/2-14	18,6
18/23	-10	5/8-14	20,6
20/27	-12	3/4-14	24,1
26/34	-16	1"-11	30,3

²⁾ standard in preparation

**Flange Fittings
 Code 61**

The 4-bolt split flange (or full flange) fitting is used worldwide for connecting high pressure hoses typically to pumps, motors and cylinders, where the hose assemblies are subjected to large pressure loadings. The sealing mechanism is through compression of the O-ring in the face of the flange head against the surface of the port/connection.

The flange fittings are generally separated into two pressure classes referred to as 3000 psi (SFL) or 6000 psi (SFS). ISO 12151-3 refers to the flange fittings as code 61 for the 3000 psi and code 62 for the 6000 psi.

In addition to these flanges, customer specific Komatsu® and CATERPILLAR® flanges can also be found in the market.

Parker end configurations

Code 61 (3000 psi)

15, 16, 17, 19, P5, P7, P9

5000 psi (Code 61 dimensions)

4A, 4F, 4N

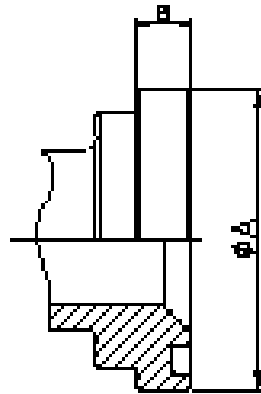

– Standard Code 61 for
 3000 to 5000 psi max., depending on size

Flange (Inch)	size	code 61	Code 62
1/2	-8	34,5/ 5000	41,3/ 6000
3/4	-12	34,5/ 5000	41,3/ 6000
1	-16	34,5/ 5000	41,3/ 6000
1.1/4	-20	27,5/ 4000	41,3/ 6000
1.1/2	-24	20,7/ 3000	41,3/ 6000
2	-32	20,7/ 3000	41,3/ 6000

Code 61 - SAE 3000PSI

Flange (Inch)	Size	OA (mm)	B (mm)	O-Ring
1/2"	-8	30,18	6,73	18,64x3,53
3/4"	-12	38,10	6,73	24,99x3,53
1"	-16	44,45	8,00	32,92x3,53
1.1/4"	-20	50,80	8,00	37,89x3,53
1.1/2"	-24	60,33	8,00	47,22x3,53
2"	-32	71,42	9,53	58,74x3,53
2.1/2"	-40	84,12	9,53	69,44x3,53
3"	-48	101,60	9,53	85,32x3,53

Working Pressure

Hose and fitting selection must be made so that the published maximum recommended working pressure of the Hose and fitting are equal to, or greater than the maximum system pressure. Surge pressures or peak transient pressures in the system must be below the maximum working pressure of the hose assembly. Surge pressures and peak pressures can usually only be determined by sensitive electrical instrumentation that measures and indicates pressures at milli-second intervals. Mechanical pressure gauges indicate only average pressures and cannot be used to determine surge pressures or peak transient pressures.

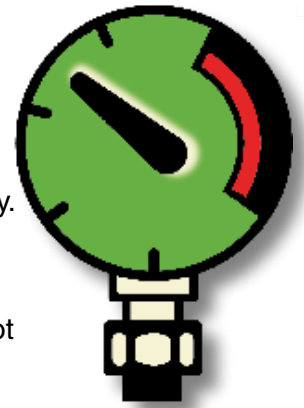

Proof Pressure Test

This test is typically carried out on customer request according to a method defined by the ISO 1402 standard. The test should be made at normal ambient temperature with a proof test bench using water or another suitable liquid. The hose assembly should be pressurised for between 30 to 60 seconds at twice the working pressure of the hose assembly. There should be no leakage or pressure drop. A complete test report should be provided together with the hose assembly to the customer.

Burst Pressure

All hoses in this catalogue have a stated burst pressure. Usually a 3:1 factor, implying therefore that the burst pressure (hose destruction) is 3 times the published working pressure.

Published burst pressure ratings for hose are for manufacturing test purposes only – burst pressure should **never** play a role in the selection of a hose.

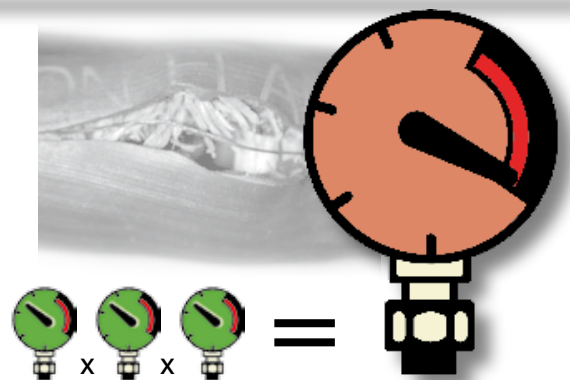

Fluid Compatibility

The hose assembly (hose inner tube, hose outer cover and hose coupling) must be chemically compatible to both the fluid being conveyed by the hose as well as the medium surrounding it. The chemical resistance table contained in the catalogue, indicates only the resistance of the coupling material to the respective fluid.

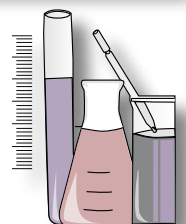

Temperature Range

In order not to negatively effect the properties of the rubber hoses it should be made certain that fluid and ambient temperatures, both steady and transient, do not exceed the limitations of the hose as published in the catalogue. Temperatures below and above the recommended limit will degrade the hose and failure may occur and release fluid.

The mechanical properties of the hose are also influenced by low or high temperatures and should be considered when designing the system.

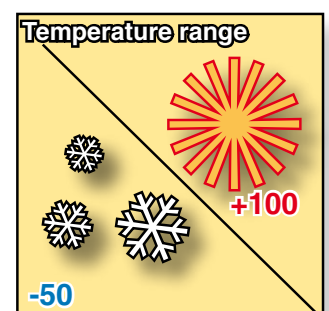

Hose Size

The power transmitted by means of a pressurised fluid varies with pressure and rate of flow. The size of the components must be adequate to keep pressure drops to a minimum and avoid aging due to heat generation or excessive fluid velocity. Size is a measurement of the inside tube of the hose – not the wall outer diameter.

Size	Inch	mm	DN
-6	6/16	$6/16 \times 25,4 = 9,525$	10
-6	3/8	9,5	10

Hose Bending Radius

The minimum bend radius of a hose refers to the minimum radius that the hose may be bent through whilst operating at the maximum allowable published working pressure.

Bending radius is not a measurement or indicator of hose flexibility. The catalogue specified values of bending radii are based on international or Parker specifications and have been proven through rigorous impulse testing of the hose assemblies.

Bending the hose below the minimum bending radius leads to loss of mechanical strength and hence possible hose failure.

A minimum straight length of 1,5 times the hose's outside diameter (D) shall be allowed between the hose fitting and the point at which the bend starts.

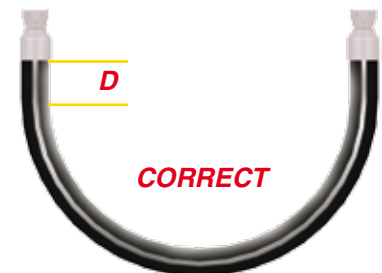
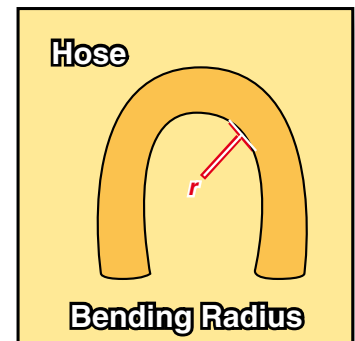

Hose Assembly Routing

The routing of a hose assembly in such a manner so as to avoid any damage to the hose by stretching, compression, kinking or abrasion over sharp edges is essential, to assure maximum service life and safety.

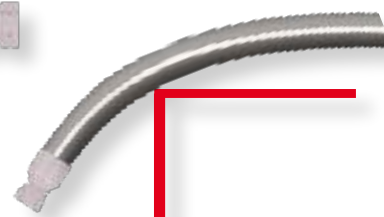
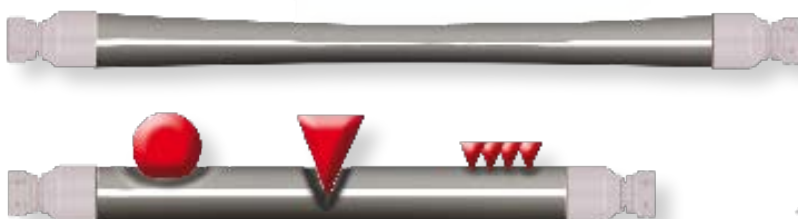

Hose and Fittings Storage

A system of age control should be maintained to ensure that hose is used before its shelf life has expired. Shelf life is the period of time when it is reasonable to expect the hose to retain full capabilities for rendering the intended service. Hose shall be stored in a manner that facilitates age control and first-in, first-out (FIFO) usage based on the manufacturing date on the hose or hose assembly. The shelf life period of rubber hose in bulk form or hose made from two or more materials (hose assembly) is difficult to define as so many factors can detrimentally influence the hoses suitability for use.

In the German speaking countries the “rules” that must be followed are stated in the DIN 20066:2002-10 and referred to by the general organisation of trade associations (Berufsgenossenschaft) in their actual publication ZH1/74 from April 2005 – safety regulations for hydraulic hose assemblies.

Excerpt DIN 20066:2002-10:

For the production of hose assemblies the hose (bulk hose) must be younger than 4 years according to the hoses date of manufacture. The service life of a hose assembly, including any period of storage should not exceed 6 years; the period of storage should not exceed 2 of these 6 years.

Additionally, the International Standard Organisation (ISO) has prepared a draft version of a guideline for hose/hose assembly usage that differs slightly from the German guideline. The ISO/TR 17165-2 states that the shelf life of hose as bulk hose or as hose made of 2 or more materials should not exceed 40 quarters (10 years) from the date of manufacture of the hose if stored in accordance with ISO 2230.

After all cases of hose storage, if visual inspection gives rise to any doubts as to the functionality of the hose (cracks in the cover, rust etc), pressure testing should be carried out before use or the hose should be disposed of. Hose assemblies should always be considered as safety relevant components, so no risks should be taken.

Hose storage – Best practices:

- Store in a clean, cool and dry area (\approx room temperature)
- Avoid direct sun light or moisture
- Do not store near high power electrical equipment
- Avoid contact with corrosive chemicals
- Avoid Ultraviolet light
- Insects/Rodents
- Radioactive materials

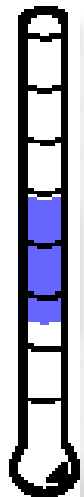

Fittings storage – Best practices:

- Additionally to the factors above the following points should be observed for storage of hose fittings
- Store fittings in clearly marked closed containers such as the original Parker packaging.
- A stock rotation system (FIFO) should be in place so that a shelf life of 2 years is not exceeded for fittings with O-rings as they may degrade as a result of normal environmental conditions, leading to possible system leakages or contamination.

Routing / Installation

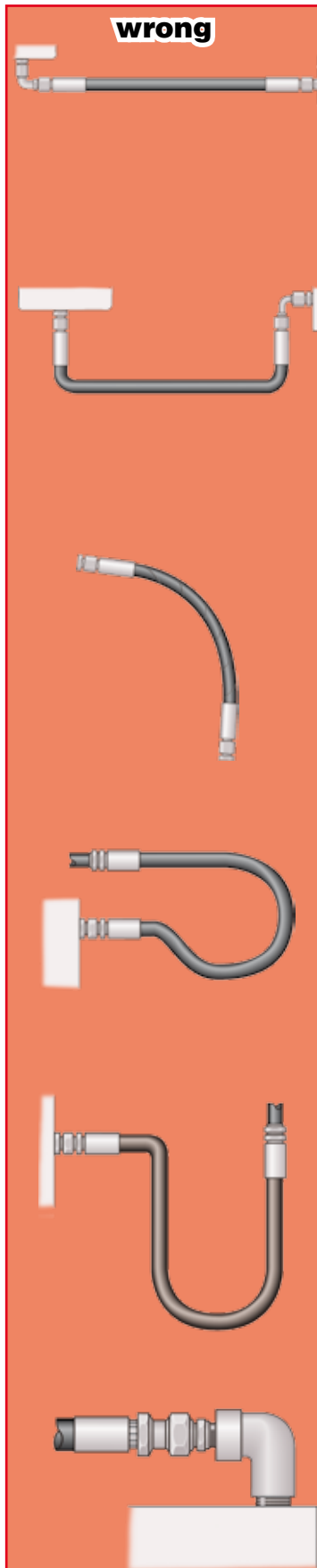

The **routing** of the hose assembly and the environment in which the hose assembly operates directly influence the service life of the hose assembly. The following diagrams indicate the correct routing of hose assemblies that will maximise its service life and assure a safe working functionality.

When hose installation is straight, it must be assured that there is enough slack in the hose to allow for changes in length that occur when pressure is applied. When pressurized, hose that is too short may pull loose from its hose fittings or stress the hose fitting connections, causing premature metallic or seal failures.

The **hose length** must be determined so that the hose assembly has enough slack to allow the system components to move or vibrate without creating tension in the hose.

However, care needs to be taken not to allow too much slack and therefore introduce the risk of the hose snagging on other equipment or rubbing on other components.

Mechanical straining of the hoses needs to be avoided, so the hose must not be bent below its minimum bending radius or twisted during installation. The minimum bending radii for each hose is stated in the hose tables in the catalogue.

The plane of movement must also be considered and the hose routing selected accordingly.

Hose routing also plays an important role on the selection of the hose fittings, as the correct fittings can avoid straining the hoses, unnecessary hose length or multiple threaded joints.

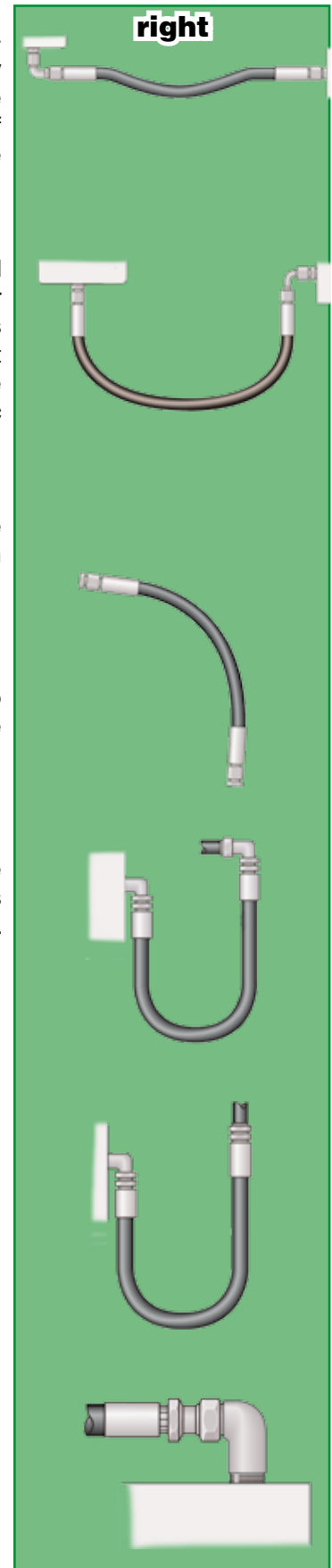

wrong

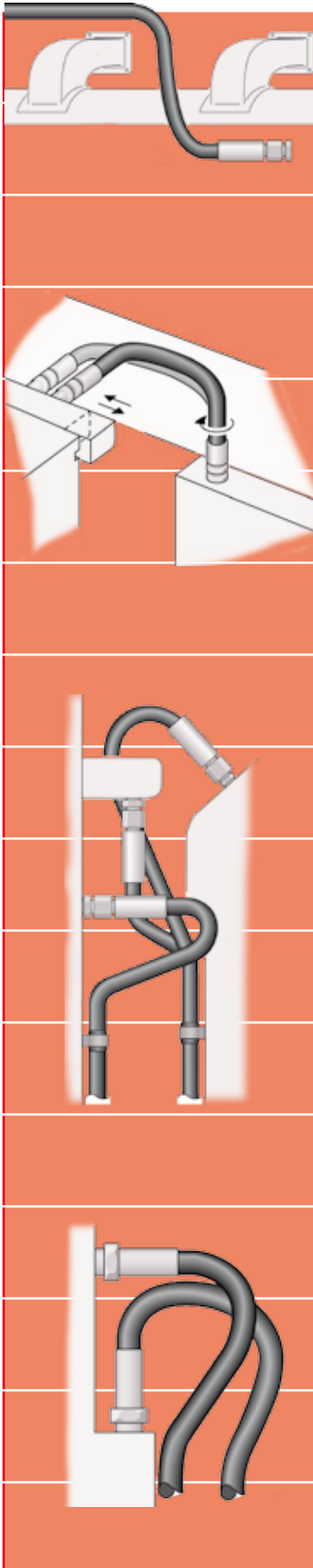

Correct clamping (holding/supporting) of the hose should be exercised to securely route the hose or to avoid the hose contacting surfaces that will cause the hose damage.

It is however, vital that the hose be allowed to keep its functionality as a “flexible-pipe” and not be restricted from changing in length when under pressure.

It should also be noted that hoses for high- and low-pressure lines shall not be crossed or clamped together, as the difference in changes in length could wear the hose covers.

Hose should not be bent in more than one plane. If hose follows a compound bend, it shall be coupled into separate segments or clamped into segments that each flex in only one plane.

Hoses should be kept away from hot parts as high ambient temperatures shorten hose life. Protective insulation may need to be used in unusually high ambient temperature areas.

Whilst the importance of the functionality is prime the aesthetics and practicality of the installation should also be considered in the design. It should be considered that maintenance might be necessary at some stage in the future, so prohibitive design routings should be avoided.

right

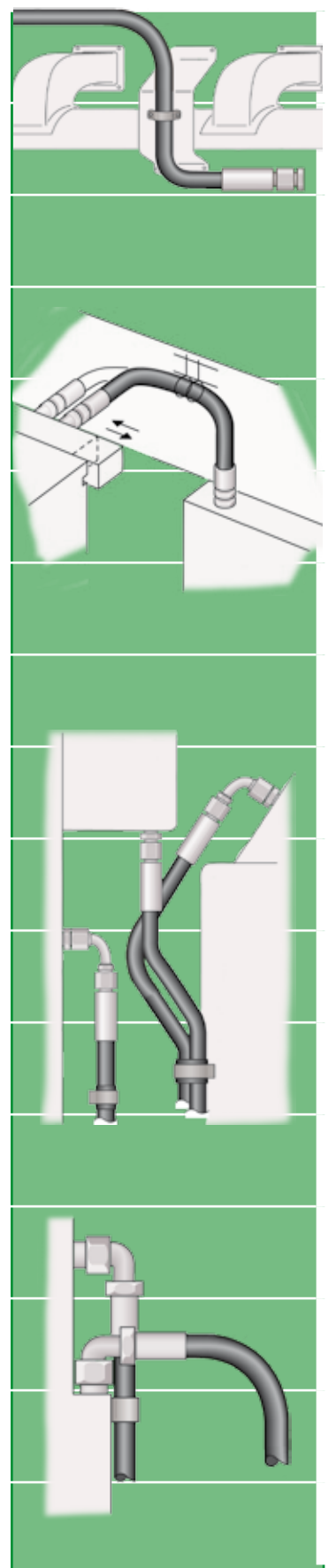

Hose Assemblies

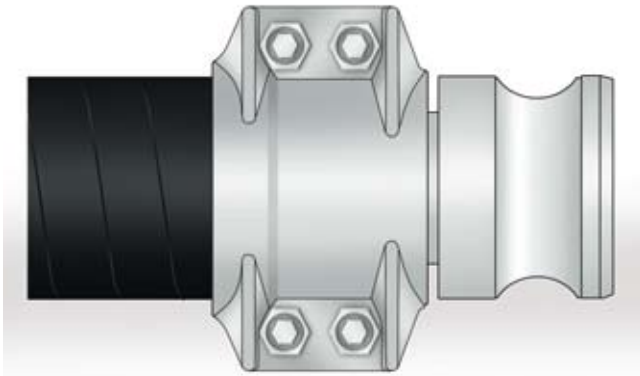

Safety clamps

One of the safest ways to assemble hoses is to use safety clamps. Safety clamps consist of two clamp shells, and are clamped around the hose end by means of nuts and bolts. In order to assemble hoses using safety clamps, you must use either a smooth hose shank complying with EN 14420-2 / DIN 2817 or a serrated hose shank with safety collar complying with EN 14423 / DIN 2826. The safety clamp collar is located behind the coupling collar to achieve a safe, secure assembly. Always check the wall thickness of hoses first, and select the recommended safety clamp accordingly.

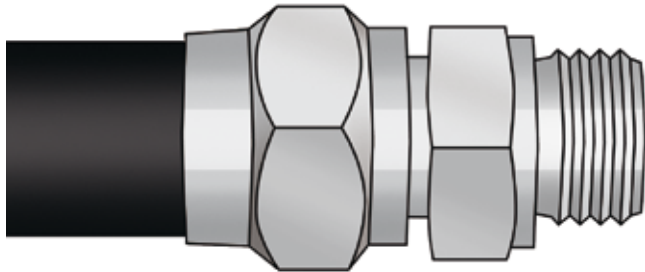

Reusable fittings

Reusable fittings are widely used for all kind of small bore oil hoses. Assembling with reusable fittings also requires the right choice of hose and most important is the right wall thickness, to grant a solid joint between hose and fitting.

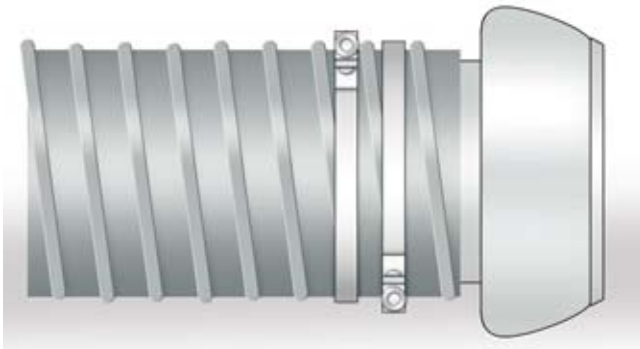

Bolt/Worm clamps

Bolt and worm clamps are often used with industrial couplings in small dimensions. The bolt/worm clamp is placed over the hose end, and closed simply by turning a screw. This fast, easy assembly method is recommended for aspiration hoses, suction hoses and (small diameter) low pressure hoses. Bolt and worm drive clamps are NOT recommended for use in high pressure applications.

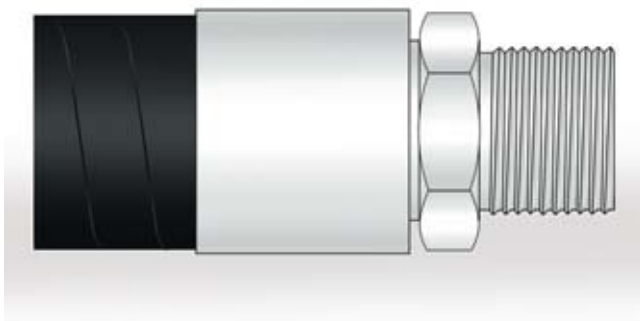

Crimping

Crimping is a metal forming technique in which the metal is formed to shape under high pressure. Swaging differs from forging in that the metal is worked cold. The internal surface of 64-series ferrules is serrated, as well as the hose nipple to reach highest performance of assembling. Crimping is recommended for a huge range of industrial applications and rubber hose, except steam applications.

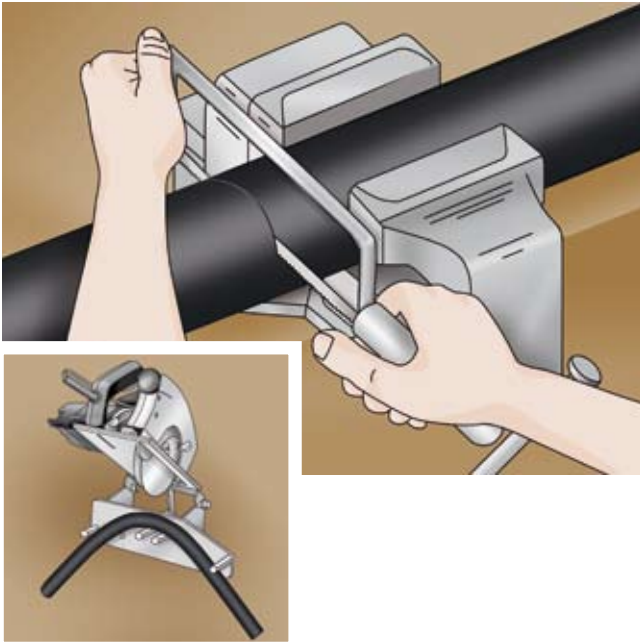

Hose Cut

Sign the cut length and cut the hose orthogonally. If necessary cut the helix.

When hoses have integrated conductive wire (steel or copper) the metal ends should be bent inside by approx. 10 mm to avoid electrical conductivity.

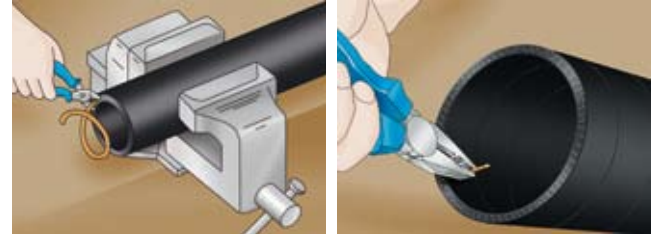

Internal bore

Insert the pyramidal caliper in the hose without forcing. Verify the absence space between caliper and the hose and read the measure.

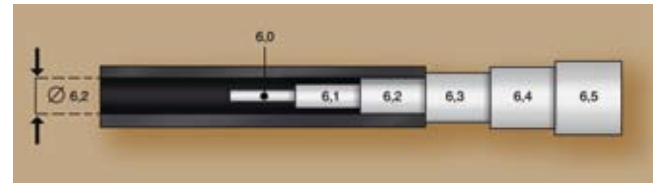

Outside diameter

Put inside the hose a pyramidal caliper; by means of a digital caliper take two orthogonal measurements, the mean value is the outside diameter.

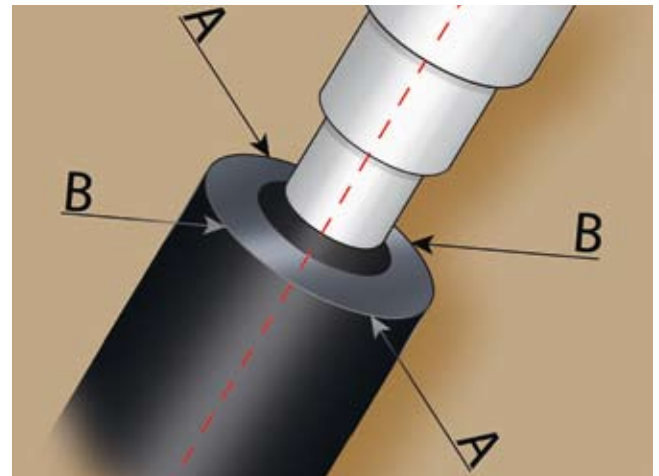

Wall thickness

Reset the digital caliper; carry out 4 orthogonal measurements and the mean value is the thickness.

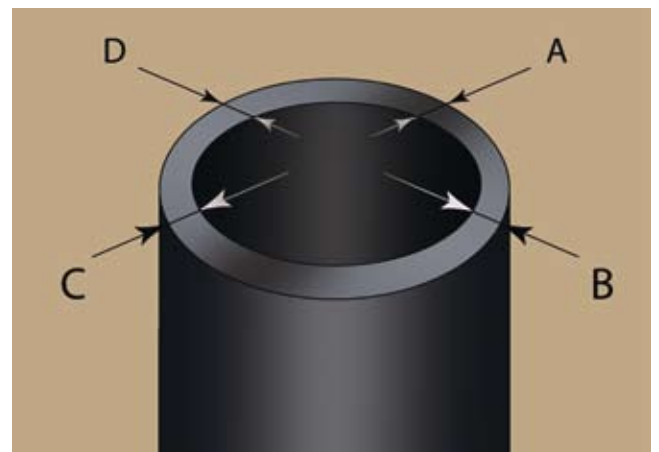
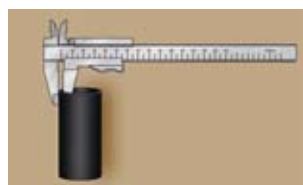

General Information

Hose Assemblies with Safety-Clamps

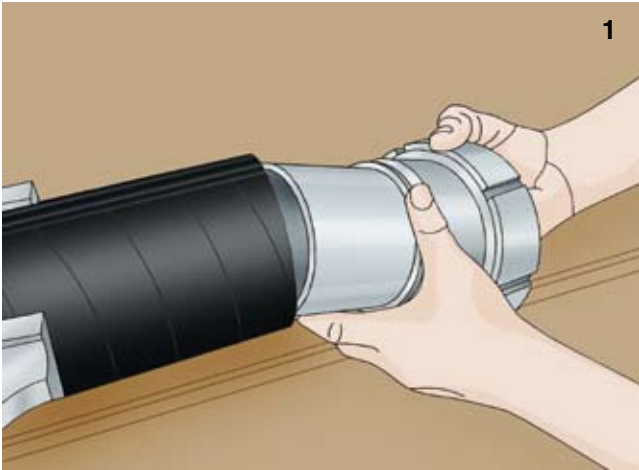

1. Choose right hose, that is designed for safety-clamps.
Cut to length and pull the hose tail all the way down, to the safety collar. For bigger diameters, a plastic hammer can be used.
For safety and stability, better use a work bench.
If electrical conductivity is necessary, hoses with embedded copper wire should be brushed with contact paste.

2. Place the clamps around the collar of the inserted coupling and screw together temporary, with longer bolts.

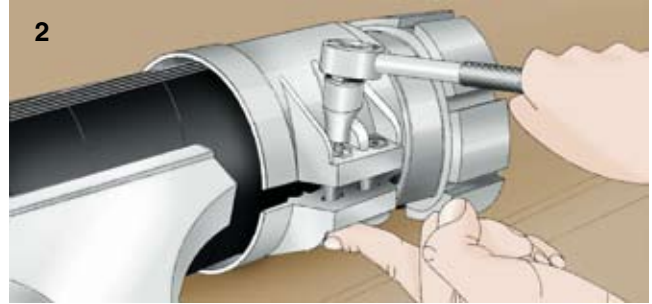

3. Put in correct bolts in remaining holes and replace the temporary used longer ones.

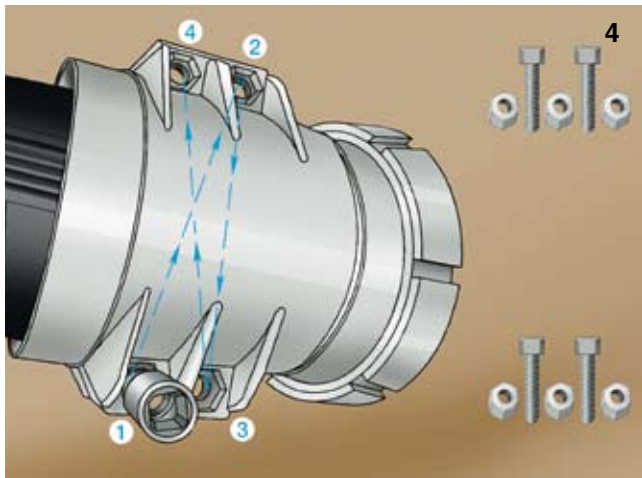
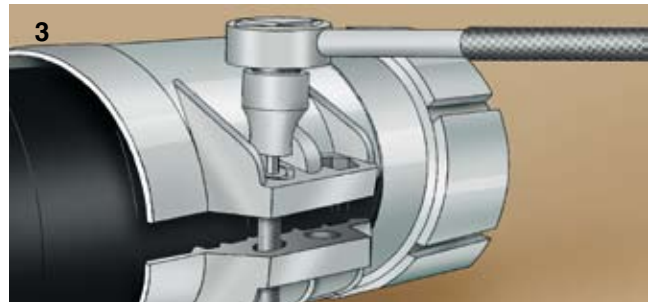

4. Always tighten the bolts diagonally and step by step.

Note

After tighten up the clamps, examine the hose assembly closely. Be sure that the clamps are mounted parallel.
If correctly assembled and all dimensions are right, there will always be a gap between the two clamp shells.
Avoid using silicone lubricants, since these are not always permitted in some industries.

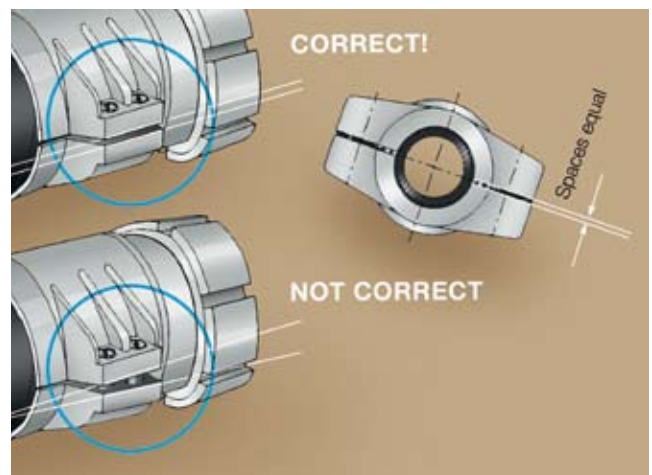

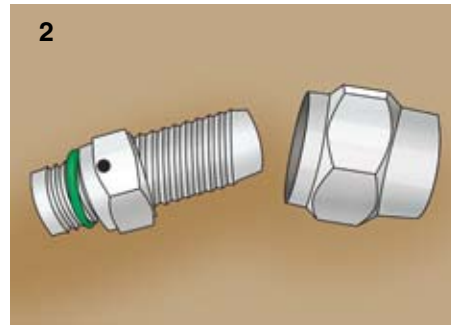
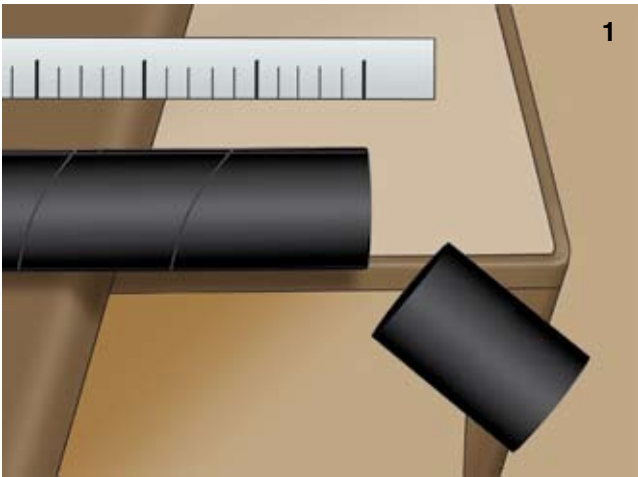

1. Cut hose to length and
2. Choose the right fitting. Watch out for right diameter and wall thickness.

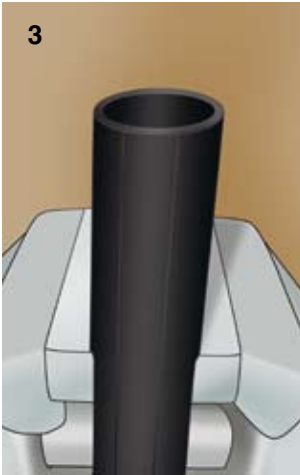

3. If electrical conductivity is required, pull out copper wire, bend around hose wall and brush with contact paste.

4. Push the ferrule all the way down on the hose and watch the small hole, if inserted totally.

5. Insert fitting and screw down with a spanner until tighten up.
6. Watch the correct position of the fitting and check again small bore. Now the compressed rubber should be seen in the hole.

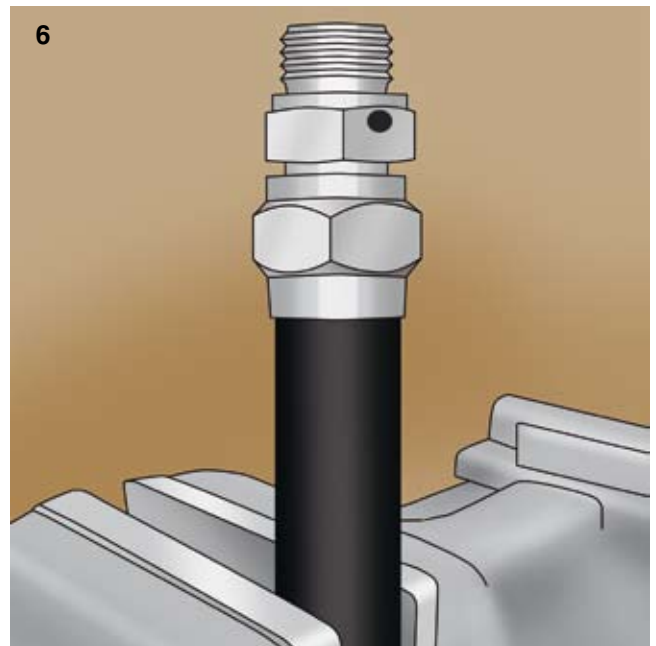
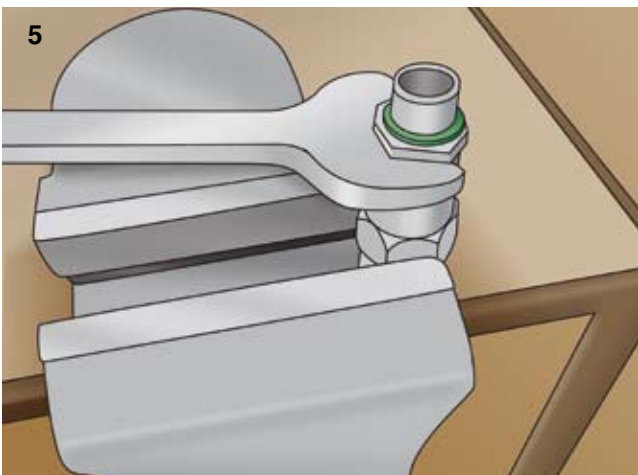

General Information
Hose Assemblies with Bolt/Worm Clamps

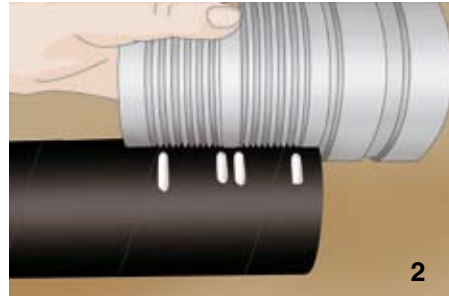
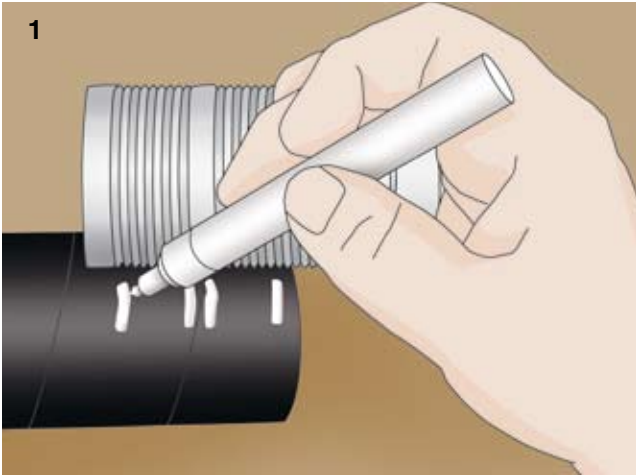

1. Choose hose and cut to length. Watch to cut right-angled. Lay fitting on the hose end and mark position of clamps.
2. Check if markings are placed in right way.

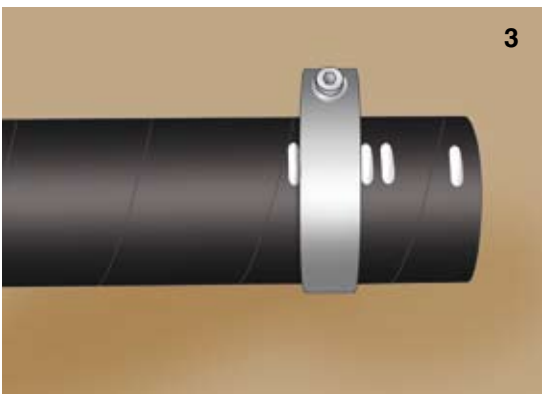

3. Place clamp between marks.

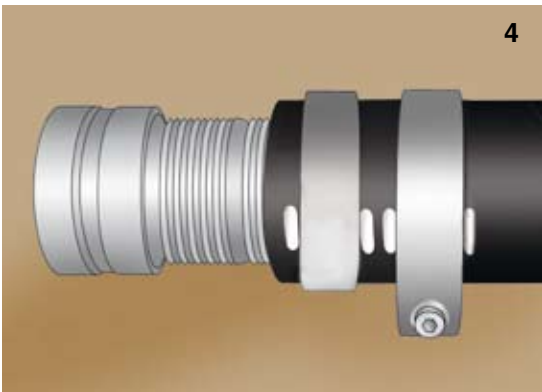

4. Insert fitting all the way into the hose. A soft hammer can be used to tap hose tails into place.



5. Tight up clamp.
Please check table for max. torque!!!

6. Check the assembling.
The outer diameter of the band should correspond with the hose OD. Bulges beside the clamp should appear.



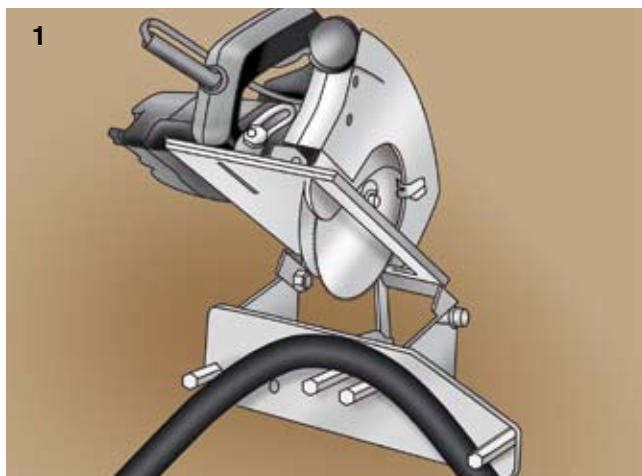

1. Choose hose and cut to length. Watch to cut right-angled.
2. Place the hose next to the fitting shell and mark the length of the ferrule onto the hose - (lubricate hose end if necessary). Push the hose all the way down into the fitting until the mark on the hose is even with the end of the ferrule.
3. Choose right die set and crimp diameter on adjustable crimper.
4. Insert hose assembly into crimper, watch correct position inside the die set, crimp to adjusted diameter.
5. Remove hose assembly from crimper and check appearance and diameter, adjust crimper again, if necessary.

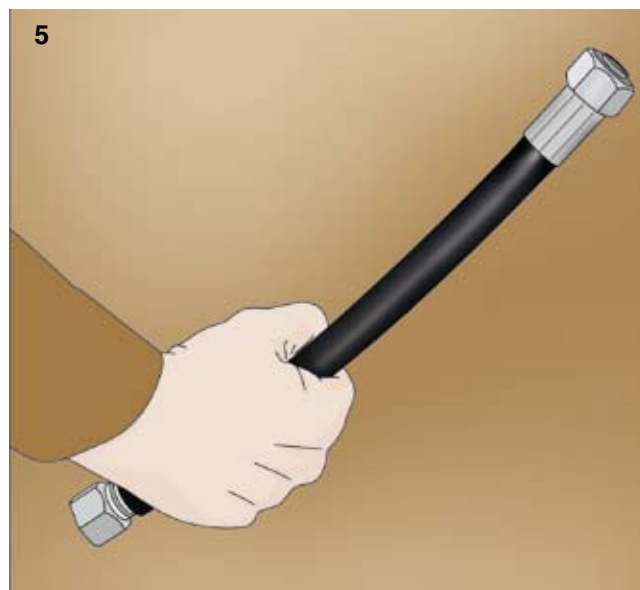

Conversion Chart

	Unit	Base Unit	Conversion Unit	Factor
Length	1 inch	in	mm	25,4
	1 millimetre	mm	in	0,03934
	1 foot	ft	m	0,3048
	1 metre	m	ft	3,28084
Area	1 square-inch	sq in	cm ²	6,4516
	1 square-centimetre	cm ²	sq in	0,1550
Volume	1 gallon (UK)	gal	l	4,54596
	1 litre	l	gal (UK)	0,219976
	1 gallon (US)	gal	l	3,78533
	1 litre	l	gal (US)	0,264177
Weight	1 pound	lb	kg	0,453592
	1 kilogramme	kg	lb	2,204622
Torque	1 pound foot	lb • ft	kg • m	1,488164
	1 newton metre	kg • m	lb • ft	0,671969
Pressure	1 pound per square inch	psi	bar	0,06895
	1 bar	bar	psi	14,5035
	1 pound per square inch	psi	MPa	0,006895
	1 mega pascal	MPa	psi	145,035
	1 kilo pascal	kPa	bar	0,01
	1 bar	bar	kPa	100
	1 mega pascal	MPa	bar	10
	1 bar	bar	MPa	0,1
Velocity	1 foot per second	ft / s	m / s	0,3048
	1 metre per second	m / s	ft / s	3,28084
Flow rate	1 gallon per minute (UK)	gal / min.	l / min.	4,54596
	1 litre per minute	l / min.	gal / min. (UK)	0,219976
	1 gallon per minute (US)	gal / min.	l / min.	3,78533
	1 litre per minute	l / min.	gal / min. (US)	0,264178
Temperature	Fahrenheit degree	°F	°C	5/9 • (°F-32)
	Celsius degree	°C	°F	°C • (9 / 5) +32

(UK) Unit of United Kingdom

(US) Unit of USA

Temperature / Pressure Chart

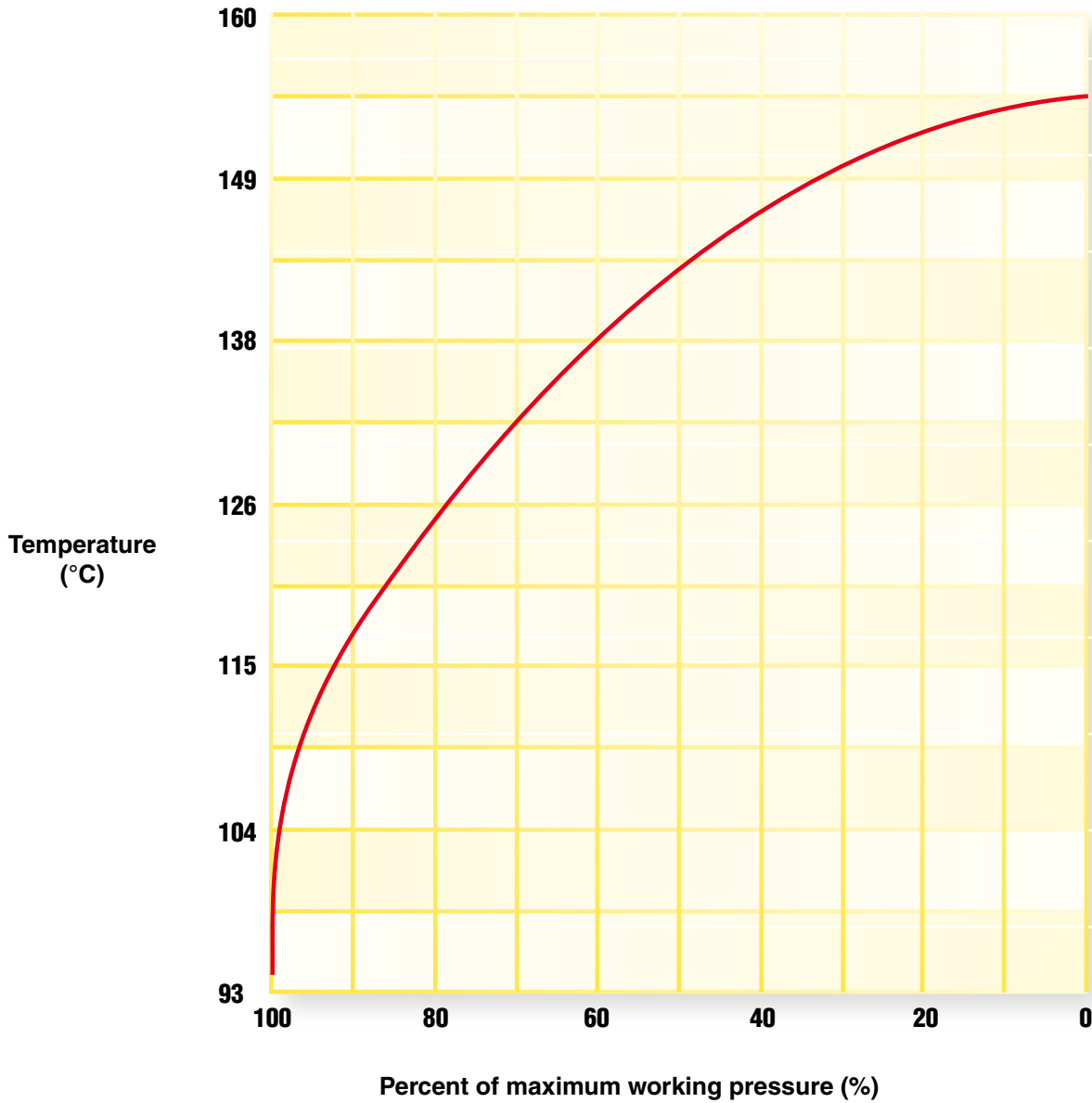

EXAMPLE: hose to be used at 121 °C

Maximum Working Pressure up to 100 °C	x	Multiplication Factor from Chart	=	Maximum Working Pressure at 121 °C
13,8 MPa (2000 psi)	x	85%	=	11,7 MPa (1700 psi)

Flow Capacity Nomogram

Flow Capacities of Parker Hose at Recommended Flow Velocities

The chart below is provided as an aid in the determination of the correct hose size.

Example: at 10 gallons per minute (gal/min), what is the proper hose size within the recommended velocity range for pressure lines?

Locate 10 gallons per minute in the left-hand column and 20 feet per second in the right-hand column (the maximum recommended velocity range for pressure lines). Lay a straight line across these two points. The inside diameter shown in the centre column is above -6 so we have to use -8 (1/2").

For suction hose, follow the same procedure except use recommended velocity range for intake lines in the right-hand column.

where: Q = flow in gallons per minute (gal/min & l/min)
V = velocity in feet per second (f/s & m/s)
d = hose inside diameter (mm & dash size)

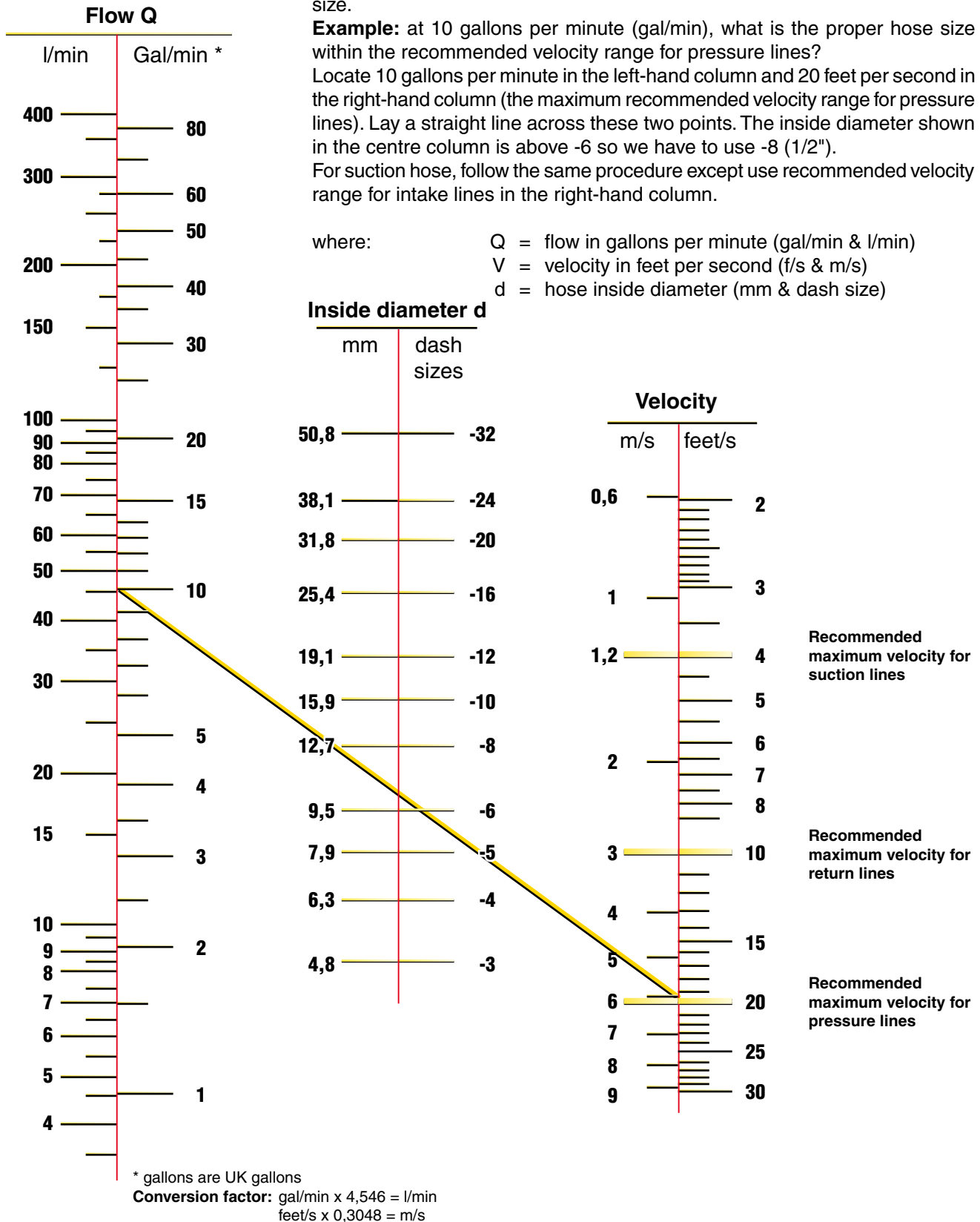

* Recommended velocities are according to hydraulic fluids of maximum viscosity 315 S.S.U. at 38°C working at roomtemperature within 18° and 68°C.

! SAFETY FIRST !

**Avoid injury to yourself and others
by following these important rules**

X

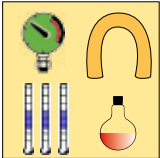

Select proper hose assemblies for the application.

Product choice must be based on published hose specifications and must fit the application requirements. Many factors and conditions affecting the inside and outside of the hose must be taken into account.



Refer to the standards, regulations and directories that apply in the countries where the equipment is sold and used.



Follow hose assembly installation good practice!

Hose must not be stretched, kinked, crushed or twisted during installation or use. Hose must not be bent to less than the minimum bend radius.



Use proper safety protection when manufacturing, testing or installing hose assemblies

Parker Hannifin recommends hose and fitting combinations in this catalog only after completing extensive testing – only use approved hose and fitting combinations.



Establish a program of inspections.

Hose assembly must be carried out by trained personnel. Update training regularly.

Safety Warnings

As rubber hoses are used for completely different purposes, they are made according to their final applications. The service life of a hose is influenced by a number of factors (environment, abrasion, fluid...).

Consequently the end user must carry out periodic preventive maintenance, above all when the conditions of use foresee high pressure service and/or conveyance of aggressive substances, and/or demanding environment. In any case, when there are signs showing possible reduction of performance, it is necessary to either substitute the product or, at least, verify it carefully. The following recommendations are the minimum that the user must adhere to and should be considered as advice to the market from the **Italian rubber hose manufacturing members of Assogomma**.

1. Recommendations for correct storage

Rubber is subject, by nature, to changes in physical properties. These changes, which normally occur over the course of time, according to the kind of rubber used, can be accelerated by one particular factor or by a combination of these.

Reinforcement materials are also adversely affected by unsuitable conditions of storage. The following recommendations give some precautions to be taken to ensure the minimum deterioration to stored articles.

1.1. Storage life

Storage time should be reduced to the minimum through programmed rotation.

When it is impossible to avoid long term storage and when the recommendations in the points below have not been respected it is necessary to check the hose carefully prior to use.

1.2. Temperature and humidity

The best temperature for the storage of rubber hoses varies from 10 to 25 degrees centigrade. Hoses should not be stored at temperatures above 40 °C or below 0 °C. When the temperature is below -15°C it is necessary to take precautions when handling. Hoses should not be stored near sources of heat nor in conditions of high or low humidity. A humidity level of a maximum of 65 % is recommended.

1.3. Light

Hoses must be stored in dark places, avoiding direct sun light or strong artificial light. Should store rooms have windows or glass openings, these must be screened.

1.4. Oxygen and ozone

Hoses should be protected from circulating air by suitable packing or by storage in air-tight containers. As ozone has a particularly aggressive action on all rubber products, the warehouse must not contain materials producing ozone like devices under high electrical tension, electric motors or other materials provoking sparks or electric arcs.

1.5. Contact with other materials

Hoses should not come into contact with solvents, fuels, oils, grease, volatile chemical mixtures, acids, disinfectants and other organic liquids in general.

Furthermore direct contact with some metals (for example manganese, iron, copper and its alloys) and relative mixtures exercise harmful effects on some types of rubber.

Contact with PVC and creosote impregnated timber or fabrics should be avoided.

1.6. Heat sources

The temperature limits given in point 1.2. must be respected. When this is impossible, it is necessary to use a thermic shield.

1.7. Electric or magnetic field

Variation in electric or magnetic fields must be eliminated in warehouses as these could provoke currents in metal coupling, heating them. Similar fields could be caused by high-tension cables or high frequency generators.

1.8. Storage conditions

Hoses must be stored in a relaxed condition free from tension, compression or other deformation and contact with objects that could pierce or cut must be avoided. It is preferable to store hoses on special shelves or on dry surfaces.

Coiled hoses must be stored horizontally avoiding piling. When this is not possible the height of the piles must be such as to avoid permanent deformation of hoses stored underneath.

The inside diameter of the coil must never be lower than twice the minimum bend radius stated by the manufacturer according to technical standards.

It is advisable to avoid storing coiled hoses on poles or hooks. Furthermore it is advisable to store hoses to be delivered straight, horizontally, without bending.

1.9. Rodents and insects

Hoses must be protected from rodents and insects. When such a risk is probable adequate precautions must be taken.

1.10. Marking of packaged items

It is advisable that hoses are always easy to identify even if packaged.

1.11. Exit from storage

Prior to delivery hoses must be checked for integrity and must correspond to the required use. After long storage if couplings are not clipped, swaged or built-in, it is necessary to check that locking collars are tight.

1.12. Return to storage

Hoses that have been used must be freed from all substances prior to storage. Particular attention must be paid when chemical, explosive inflammable, abrasive and corrosive substances have been conveyed. After cleaning, check whether the hose is suitable to use again.

2. Norms and method of use

After having chosen the type of hose, users must keep in mind the following hose installation criteria.

2.1. Preassembly checks

Prior to installation it is necessary to check the characteristics of the hose carefully to verify that type, diameter and length conform with the required specifications. Moreover a visual check must be effected to make sure that there are no obstructions, cuts, damaged cover or any other evident imperfections.

2.2. Handling

Hoses must be moved with care avoiding knocks, dragging over abrasive surfaces and compression. Hoses must not be pulled violently when twisted or knotted. Heavy hoses, normally delivered in a as straights, must be laid on special supports for transport. Should wood support be used these must not be treated with creosote or painted with substances which could damage the rubber.

2.3. Pressure and seal test

The working pressure generally indicated on hoses must be respected. Following installation, when air bubbles have been eliminated, increase the pressure gradually - the working pressure to test the assembly and check possible leaks. This test must be carried out in a place free from danger.

2.4. Temperature

Hoses must always be used within the temperature limits generally indicated. In case of doubt apply to manufacturer.

2.5. Conveyed products

Hoses must be used exclusively to convey substances for which they were manufactured. In case of doubt it is always advisable to contact manufacturer. The hoses are designed to transport the fluids listed in the specifications; the hoses are not designed to be submerged in these fluids. For such applications it is advisable to seek further advice by contacting our sales organisation. As far as possible, hoses must not remain under strain when not in use. Where any risks are involved special precautions must be taken to avoid bursts.

2.6. Environment

Hoses must be used exclusively in the environment conditions for which they were manufactured.

2.7. Bending radius

Installation underneath the minimum bending radius reduces the life of the hose considerably. Moreover it is necessary to avoid bending at fitting ends.

2.8. Torsion

Hoses are not manufactured to work in torsion, except for specific purposes.

2.9. Tension

Tension must be within limits specified by manufacturer.

2.10. Vibration

Vibrations subject hoses to stress from heat and fatigue above all near couplings and premature bursting may occur. It is therefore advisable to check that hoses have been manufactured to resist such stress.

2.11. Kinking

Some users tend to obstruct the flow of liquids by kinking the hose. This system is not advised by manufacturers because the reinforcement is subjected to excessive stress and could lead to bursting.

2.12. Choice and application of couplings

Provided that the manufacturers instructions are met it is always necessary to check the compatibility between the working pressure of couplings and hoses. Couplings with too large diameters cause abnormal stress which can split the hose

reinforcement, whilst too small dimensions can create clamping difficulties and leakage.

Furthermore couplings must be free from sharp and cutting edges which could damage the hose. Water or soap and water can be used to fit couplings. Do not use products containing oils or solvents except for the kind of hoses destined to be used with the latter .

Softening hoses with a mallet or similar tools is forbidden.

Take care to avoid external collars or other tightening tools. The use of makeshift collars (for example wire) with sharp edges or too tight clamping leads to damage of cover and reinforcement.

2.13. Evacuation of static electricity

When electrical continuity is requested, manufacturers instructions must be met, test must be carried out to check the continuity between the coupling and the assembly. Check the continuity with a simple appliance (for example "Quick Test") otherwise it is necessary to use a tester.

2.14. Permanent installation

The hoses must be supported in a suitable way, so as the normal movement when the hose is under pressure (variations in length, diameter, twisting, etc.) are allowed.

2.15. Moving parts

When hoses link moving parts, it is necessary to check that the length of the hose is suitable and that the movement does not subject the hose to shock or chafing and that abnormal stress, bending, tension or torsion do not occur.

2.16. Identification

If further marking is necessary , self-adhesive tape may be used. When the use of paint is unavoidable check compatibility of cover with manufacturer.

3. Maintenance

Even though choice, storage and installation have been carried out correctly regular maintenance is necessary. Frequency of the latter is determined according to use involved. During regular checks special attention must be paid to couplings and to the appearance of the following irregularities which show deterioration of hose:

- cracks, cuts, abrasions, unsticking, tears in cover revealing reinforcement;
- deformity , bubbles, local swelling under pressure;
- sticky or soft areas;
- leaks.

Such irregularities justify hose substitutions. When cover bears date of expiry this must be kept to even if the hose shows no apparent sign of wear.

3.1. Repairs

Hose repairs are not advisable. However when deterioration occurs at an end section, and if the full length allows for such, the worn section may be eliminated.

Cleaning

If cleaning instructions are not supplied by the manufacturer clean, if necessary, with soap and water avoiding use of solvents (petrol, paraffin, etc.) or detergents. Never use abrasive, pointed or cutting tools (wire brushes).



aerospace
climate control
electromechanical
filtration
fluid & gas handling
hydraulics
pneumatics
process control
sealing & shielding



Kamlock Couplings

Cam & Groove



ENGINEERING YOUR SUCCESS.

a - Kamlock

a

Pressure range

Size	1/2"		3/4" - 2"		2 1/2"		3"		4"		5"		6"		8"	
	bar	psi	bar	psi	bar	psi	bar	psi	bar	psi	bar	psi	bar	psi	bar	psi
Brass	11	150	18	250	11	150	9	125	7	100	5	75	5	75	-	-
Aluminium	11	150	18	250	11	150	9	125	7	100	5	75	5	75	5	75
Stainless steel	11	150	18	250	16	225	14	200	7	100	7	100	7	100	3	50

Temperature range

The working pressures shown above refer to ambient temperatures using elastomer seals. Higher temperatures and / or PTFE seals will reduce the rated coupling pressure. In the case of polypropylene, the maximum working temperature is 70 °C (160 °F), at which temperature the working pressures shown above should be reduced by 40 %. Hose, coupling, seal and assembly method must be chosen in relation with the desired application and temperature range.

Materials

Kamlock couplings are available in the following materials

- Stainless steel:
ASTM A666 grade 316 / 1.4401
- Brass:
ASTM B584 grade C85700
- Aluminium:
ASTM B85 grade 380
- Polypropylene:
PP couplings contain 25-30 % fiberglass reinforcements

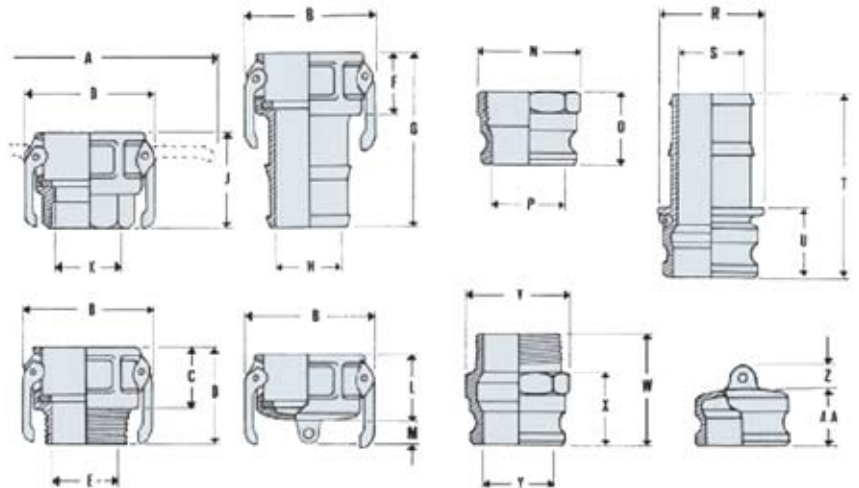

Dimensions

ND	Size	A	B	C	D	E	F	G	H	J	K	L
13	1/2"	30	40	31	46	13	31	66	10	46	14	33
20	3/4"	115	50	33	49	19	55	85	14	49	21	34
25	1"	138	62	40	60	24	40	98	20	60	26	41
32	1.1/4"	178	81	46	68	31	46	104	26	70	35	48
40	1.1/2"	185	87	48	70	38	48	109	32	73	38	50
50	2"	195	90	54	79	48	54	124	43	79	46	57
65	2.1/2"	208	111	55	85	62	55	135	54	87	56	59
80	3"	250	143	57	90	75	57	159	66	92	73	62
100	4"	270	171	61	101	100	61	169	89	101	98	65
125	5"	300	-	61	101	122	61	188	118	105	128	65
150	6"	400	254	67	112	150	67	240	140	111	144	73

M	N	O	P	S	T	U	V	W	X	Y	Z	AA
13	24	37	14	10	62	28	24	52	37	14	4	26
13	32	40	19	14	76	25	32	57	40	19	10	26
13	43	48	23	19	92	36	43	69	49	23	10	23
13	50	55	28	25	98	41	58	77	55	28	10	40
13	56	36	36	31	102	44	56	78	56	36	10	42
13	68	62	46	43	117	49	68	87	62	46	10	48
13	85	86	56	56	129	51	85	98	68	56	10	49
13	102	88	73	64	153	51	102	108	70	73	10	51
13	126	78	98	89	168	55	126	118	78	98	12	53
13	-	83	118	118	188	56	-	103	63	118	12	58
16	-	82	150	138	230	60	-	108	68	150	12	58

Male coupler with serrated hose shank

Coupling standard: **Federal Mil A-A-59326A**
 Material: **Aluminium, Stainless Steel, Brass, Polypropylene**
 For hose type: **POLIAX, CARBURITE, CARBOCORD, CHEMIOEL, FUCINO, WATER, IDRO, BEVERA**
 Assembly:

Safety Clamps	Worm Drive	Bolt clamps	Crimping
	X	X	

Aluminium



Part-No.	Hose I.D. mm	Inch	Collar	Weight kg/pcs
VLEA019	19	3/4	x	0,05
VLEA025	25	1	x	0,09
VLEA032	32	1 1/4	x	0,12
VLEA038	38	1 1/2	x	0,19
VLEA050	50	2	x	0,28
VLEA063	63	2 1/2	x	0,45
VLEA075	75	3	x	0,66
VLEA100	100	4	x	1,13
VLEA125	125	5	x	1,48
VLEA150	150	6	x	2,20

Stainless Steel (AISI 316/1.4401)



Part-No.	Hose I.D. mm	Inch	Collar	Weight kg/pcs
VLER019	19	3/4	x	0,14
VLER025	25	1	x	0,25
VLER032	32	1 1/4	x	0,37
VLER038	38	1 1/2	x	0,56
VLER050	50	2	x	0,85
VLER063	63	2 1/2	x	1,17
VLER075	75	3	x	1,73
VLER100	100	4	x	2,85
VLER125	125	5	x	4,05
VLER150	150	6	x	5,64

Brass



Part-No.	Hose I.D. mm	Inch	Collar	Weight kg/pcs
VLEM019	19	3/4	x	0,15
VLEM025	25	1	x	0,24
VLEM032	32	1 1/4	x	0,33
VLEM038	38	1 1/2	x	0,44
VLEM050	50	2	x	0,73
VLEM063	63	2 1/2	x	0,96
VLEM075	75	3	x	1,25
VLEM100	100	4	x	1,91
VLEM125	125	5	x	4,54
VLEM150	150	6	x	5,07

Polypropylene



Part-No.	Hose I.D. mm	Inch	Collar	Weight kg/pcs
VLEP013	13	1/2	x	0,01
VLEP019	19	3/4	x	0,03
VLEP025	25	1	x	0,04
VLEP032	32	1 1/4	x	0,07
VLEP038	38	1 1/2	x	0,09
VLEP050	50	2	x	0,15
VLEP075	75	3	x	0,35
VLEP100	100	4	x	0,55

Female coupler with serrated hose shank

Coupling standard: **Federal Mil A-A-59326A**
 Material: **Aluminium, Stainless Steel, Brass, Polypropylene**
 For hose type: **POLIAX, CARBURITE, CARBOCORD, CHEMIOEL, FUCINO, WATER, IDRO, BEVERA**
 Assembly:

Safety Clamps	Worm Drive	Bolt clamps	Crimping
	X	X	

Aluminium



Part-No.	Hose I.D. mm	Inch	Collar	Handles	Weight kg/pcs
VLCA019	19	3/4	-	2	0,12
VLCA025	25	1	-	2	0,17
VLCA032	32	1 1/4	-	2	0,28
VLCA038	38	1 1/2	-	2	0,34
VLCA050	50	2	-	2	0,44
VLCA063	63	2 1/2	-	2	0,59
VLCA075	75	3	-	2	0,86
VLCA100	100	4	-	2	1,25
VLCA125	125	5	-	2	1,68
VLCA150	150	6	-	2	2,66

Stainless Steel (AISI 316/1.4401)



Part-No.	Hose I.D. mm	Inch	Collar	Handles	Weight kg/pcs
VLCR019	19	3/4	x	2	0,25
VLCR025	25	1	x	2	0,37
VLCR032	32	1 1/4	x	2	0,59
VLCR038	38	1 1/2	x	2	0,70
VLCR050	50	2	x	2	0,81
VLCR063	63	2 1/2	x	2	1,34
VLCR075	75	3	x	2	1,97
VLCR100	100	4	x	2	3,14
VLCR125	125	5	x	2	4,96
VLCR150	150	6	x	2	5,58

Brass



Part-No.	Hose I.D. mm	Inch	Collar	Handles	Weight kg/pcs
VLCM019	19	3/4	-	2	0,23
VLCM025	25	1	-	2	0,36
VLCM032	32	1 1/4	-	2	0,49
VLCM038	38	1 1/2	-	2	0,62
VLCM050	50	2	-	2	0,77
VLCM063	63	2 1/2	-	2	1,07
VLCM075	75	3	-	2	1,58
VLCM100	100	4	-	2	4,13
VLCM125	125	5	-	2	3,32
VLCM150	150	6	-	2	6,05

Polypropylene



Part-No.	Hose I.D. mm	Inch	Collar	Handles	Weight kg/pcs
VLCP013	13	1/2	-	2	0,07
VLCP019	19	3/4	-	2	0,08
VLCP025	25	1	-	2	0,12
VLCP032	32	1 1/4	-	2	0,23
VLCP038	38	1 1/2	-	2	0,23
VLCP050	50	2	-	2	0,31
VLCP075	75	3	-	2	0,64
VLCP100	100	4	-	2	0,90

Male coupler with hose shank DIN 2817

Coupling standard: **EN 14420-7 / DIN 2828**
 Shank standard: **EN 14420-2 / DIN 2828**
 Material: **Stainless Steel, Brass**
 For hose type: **POLIAX, CARBURITE, CARBOCORD, CHEMIOEL, IDRO**
 Assembly:

Safety Clamps	Worm Drive	Bolt clamps	Crimping
X			



Stainless Steel (AISI 316/1.4401)

Part-No.	Hose I.D. mm	Inch	Weight kg/pcs
VLER019D	19	3/4	0,13
VLER025D	25	1	0,20
VLER032D	32	1 1/4	0,33
VLER038D	38	1 1/2	0,45
VLER050D	50	2	0,58
VLER063D	63	2 1/2	0,96
VLER075D	75	3	1,16
VLER100D	100	4	2,26



Brass

Part-No.	Hose I.D. mm	Inch	Weight kg/pcs
VLEM019D	19	3/4	0,14
VLEM025D	25	1	0,21
VLEM032D	32	1 1/4	0,35
VLEM038D	38	1 1/2	0,45
VLEM050D	50	2	0,66
VLEM063D	63	2 1/2	0,98
VLEM075D	75	3	1,26
VLEM100D	100	4	2,69

Female coupler with hose shank DIN 2817

Coupling standard: **EN 14420-7 / DIN 2828**
 Shank standard: **EN 14420-2 / DIN 2828**
 Material: **Stainless Steel, Brass**
 For hose type: **POLIAX, CARBURITE, CARBOCORD, CHEMIOEL, IDRO**
 Assembly:

Safety Clamps	Worm Drive	Bolt clamps	Crimping
X			



Stainless Steel (AISI 316/1.4401)

Part-No.	Hose I.D. mm	Inch	Weight kg/pcs
VLCR019D	19	3/4	0,24
VLCR025D	25	1	0,35
VLCR032D	32	1 1/4	0,59
VLCR038D	38	1 1/2	0,68
VLCR050D	50	2	0,9
VLCR063D	63	2 1/2	1,24
VLCR075D	75	3	1,57
VLCR100D	100	4	2,59

Brass



Part-No.	Hose I.D. mm	Inch	Weight kg/pcs
VLCM019D	19	3/4	0,25
VLCM025D	25	1	0,38
VLCM032D	32	1 1/4	0,63
VLCM038D	38	1 1/2	0,69
VLCM050D	50	2	0,91
VLCM063D	63	2 1/2	1,18
VLCM075D	75	3	1,57
VLCM100D	100	4	2,71

Male coupler with female thread

Coupling standard: **Federal Mil A-A-59326A / EN 14420-7 / DIN 2828**
 Thread: **EN 10226-1 / EN ISO 228-1**
 Material: **Aluminium, Stainless Steel, Brass, Polypropylene**
 For hose type: **POLIAX, CARBURITE, CARBOCORD, CHEMIOEL, FUCINO, WATER, IDRO, BEVERA**

Aluminium



Part-No.	Hose I.D. mm	Inch	Thread	Weight kg/pcs
VLAA013	13	1/2	G1/2	0,02
VLAA019	19	3/4	G3/4	0,04
VLAA025	25	1	G1	0,05
VLAA032	32	1 1/4	G1 1/4	0,09
VLAA038	38	1 1/2	G1 1/2	0,11
VLAA050	50	2	G2	0,15
VLAA063	63	2 1/2	G2 1/2	0,24
VLAA075	75	3	G3	0,27
VLAA100	100	4	G4	0,58

Stainless Steel (AISI 316/1.4401)



Part-No.	Hose I.D. mm	Inch	Thread	Weight kg/pcs
VLAR013	13	1/2	G1/2	0,07
VLAR019	19	3/4	G3/4	0,11
VLAR025	25	1	G1	0,15
VLAR032	32	1 1/4	G1 1/4	0,24
VLAR038	38	1 1/2	G1 1/2	0,32
VLAR050	50	2	G2	0,42
VLAR063	63	2 1/2	G2 1/2	0,71
VLAR075	75	3	G3	0,73
VLAR100	100	4	G4	1,42

Brass



Part-No.	Hose I.D. mm	Inch	Thread	Weight kg/pcs
VLAM013	13	1/2	G1/2	0,07
VLAM019	19	3/4	G3/4	0,10
VLAM025	25	1	G1	0,15
VLAM032	32	1 1/4	G1 1/4	0,20
VLAM038	38	1 1/2	G1 1/2	0,29
VLAM050	50	2	G2	0,35
VLAM063	63	2 1/2	G2 1/2	0,72
VLAM075	75	3	G3	0,73
VLAM100	100	4	G4	1,48

Polypropylene



Part-No.	Hose I.D. mm	Inch	Thread	Weight kg/pcs
VLAP013	13	1/2	G1/2	0,02
VLAP019	19	3/4	G3/4	0,02
VLAP025	25	1	G1	0,03
VLAP032	32	1 1/4	G1 1/4	0,05
VLAP038	38	1 1/2	G1 1/2	0,07
VLAP050	50	2	G2	0,09
VLAP075	75	3	G3	0,21
VLAP100	100	4	G4	0,36

Male coupler with male thread

Coupling standard: **Federal Mil A-A-59326A / EN 14420-7 / DIN 2828**
 Thread: **EN 10226-1 / EN ISO 228-1**
 Material: **Aluminium, Stainless Steel, Brass, Polypropylene**
 For hose type: **POLIAX, CARBURITE, CARBOCORD, CHEMIOEL, FUCINO, WATER, IDRO, BEVERA**

a

Aluminium



Part-No.	Hose I.D. mm	Inch	Thread	Weight kg/pcs
VLFA013	13	1/2	R1/2	0,03
VLFA019	19	3/4	R3/4	0,07
VLFA025	25	1	R1	0,09
VLFA032	32	1 1/4	R1 1/4	0,12
VLFA038	38	1 1/2	R1 1/2	0,18
VLFA050	50	2	R2	0,26
VLFA063	63	2 1/2	R2 1/2	0,36
VLFA075	75	3	R3	0,51
VLFA100	100	4	R4	0,92

Stainless Steel (AISI 316/1.4401)



Part-No.	Hose I.D. mm	Inch	Thread	Weight kg/pcs
VLFR013	13	1/2	R1/2	0,09
VLFR019	19	3/4	R3/4	0,16
VLFR025	25	1	R1	0,26
VLFR032	32	1 1/4	R1 1/4	0,40
VLFR038	38	1 1/2	R1 1/2	0,52
VLFR050	50	2	R2	0,69
VLFR063	63	2 1/2	R2 1/2	0,98
VLFR075	75	3	R3	1,42
VLFR100	100	4	R4	2,52

Brass



Part-No.	Hose I.D. mm	Inch	Thread	Weight kg/pcs
VLFM013	13	1/2	R1/2	0,09
VLFM019	19	3/4	R3/4	0,15
VLFM025	25	1	R1	0,23
VLFM032	32	1 1/4	R1 1/4	0,30
VLFM038	38	1 1/2	R1 1/2	0,35
VLFM050	50	2	R2	0,51
VLFM063	63	2 1/2	R2 1/2	0,80
VLFM075	75	3	R3	0,94
VLFM100	100	4	R4	1,71

Polypropylene



Part-No.	Hose I.D. mm	Inch	Thread	Weight kg/pcs
VLFP013	13	1/2	R1/2	0,02
VLFP019	19	3/4	R3/4	0,03
VLFP025	25	1	R1	0,05
VLFP032	32	1 1/4	R1 1/4	0,08
VLFP038	38	1 1/2	R1 1/2	0,10
VLFP050	50	2	R2	0,14
VLFP075	75	3	R3	0,29
VLFP100	100	4	R4	0,42

Female coupler with female thread

Coupling standard: **Federal Mil A-A-59326A / EN 14420-7 / DIN 2828**
 Thread: **EN 10226-1 / EN ISO 228-1**
 Material: **Aluminium, Stainless Steel, Brass, Polypropylene**
 For hose type: **POLIAX, CARBURITE, CARBOCORD, CHEMIOEL, FUCINO, WATER, IDRO, BEVERA**

Aluminium



Part-No.	Hose I.D. mm	Inch	Thread	Handles	Weight kg/pcs
VLDA013	13	1/2	G1/2	1	0,06
VLDA019	19	3/4	G3/4	2	0,12
VLDA025	25	1	G1	2	0,16
VLDA032	32	1 1/4	G1 1/4	2	0,28
VLDA038	38	1 1/2	G1 1/2	2	0,32
VLDA050	50	2	G2	2	0,36
VLDA063	63	2 1/2	G2 1/2	2	0,47
VLDA075	75	3	G3	2	0,73
VLDA100	100	4	G4	2	1,21

Stainless Steel (AISI 316/1.4401)



Part-No.	Hose I.D. mm	Inch	Thread	Handles	Weight kg/pcs
VLDR013	13	1/2	G1/2	1	0,13
VLDR019	19	3/4	G3/4	2	0,23
VLDR025	25	1	G1	2	0,31
VLDR032	32	1 1/4	G1 1/4	2	0,49
VLDR038	38	1 1/2	G1 1/2	2	0,55
VLDR050	50	2	G2	2	0,70
VLDR063	63	2 1/2	G2 1/2	2	1,00
VLDR075	75	3	G3	2	1,30
VLDR100	100	4	G4	2	2,14

Brass



Part-No.	Hose I.D. mm	Inch	Thread	Handles	Weight kg/pcs
VLDM013	13	1/2	G1/2	1	0,16
VLDM019	19	3/4	G3/4	2	0,22
VLDM025	25	1	G1	2	0,32
VLDM032	32	1 1/4	G1 1/4	2	0,46
VLDM038	38	1 1/2	G1 1/2	2	0,54
VLDM050	50	2	G2	2	0,67
VLDM063	63	2 1/2	G2 1/2	2	0,94
VLDM075	75	3	G3	2	1,40
VLDM100	100	4	G4	2	2,09

Polypropylene



Part-No.	Hose I.D. mm	Inch	Thread	Handles	Weight kg/pcs
VLDP013	13	1/2	G1/2	2	0,07
VLDP019	19	3/4	G3/4	2	0,08
VLDP025	25	1	G1	2	0,13
VLDP032	32	1 1/4	G1 1/4	2	0,21
VLDP038	38	1 1/2	G1 1/2	2	0,23
VLDP050	50	2	G2	2	0,27
VLDP075	75	3	G3	2	0,50
VLDP100	100	4	G4	3	0,75

Female coupler with male thread

Coupling standard: **Federal Mil A-A-59326A / EN 14420-7 / DIN 2828**
 Thread: **EN 10226-1 / EN ISO 228-1**
 Material: **Aluminium, Stainless Steel, Brass, Polypropylene**
 For hose type: **POLIAX, CARBURITE, CARBOCORD, CHEMIOEL, FUCINO, WATER, IDRO, BEVERA**

a

Aluminium



Part-No.	Hose I.D. mm	Inch	Thread	Handles	Weight kg/pcs
VLBA013	13	1/2	R1/2	1	0,07
VLBA019	19	3/4	R3/4	2	0,10
VLBA025	25	1	R1	2	0,16
VLBA032	32	1 1/4	R1 1/4	2	0,27
VLBA038	38	1 1/2	R1 1/2	2	0,30
VLBA050	50	2	R2	2	0,35
VLBA063	63	2 1/2	R2 1/2	2	0,43
VLBA075	75	3	R3	2	0,68
VLBA100	100	4	R4	2	0,92

Stainless Steel (AISI 316/1.4401)



Part-No.	Hose I.D. mm	Inch	Thread	Handles	Weight kg/pcs
VLBR013	13	1/2	R1/2	1	0,12
VLBR019	19	3/4	R3/4	2	0,20
VLBR025	25	1	R1	2	0,29
VLBR032	32	1 1/4	R1 1/4	2	0,47
VLBR038	38	1 1/2	R1 1/2	2	0,54
VLBR050	50	2	R2	2	0,67
VLBR063	63	2 1/2	R2 1/2	2	1,14
VLBR075	75	3	R3	2	1,35
VLBR100	100	4	R4	2	1,97

Brass



Part-No.	Hose I.D. mm	Inch	Thread	Handles	Weight kg/pcs
VLBM013	13	1/2	R1/2	1	0,17
VLBM019	19	3/4	R3/4	2	0,21
VLBM025	25	1	R1	2	0,32
VLBM032	32	1 1/4	R1 1/4	2	0,45
VLBM038	38	1 1/2	R1 1/2	2	0,52
VLBM050	50	2	R2	2	0,64
VLBM063	63	2 1/2	R2 1/2	2	0,94
VLBM075	75	3	R3	2	1,38
VLBM100	100	4	R4	2	1,94

Polypropylene



Part-No.	Hose I.D. mm	Inch	Thread	Handles	Weight kg/pcs
VLBP013	13	1/2	R1/2	2	0,07
VLBP019	19	3/4	R3/4	2	0,08
VLBP025	25	1	R1	2	0,11
VLBP032	32	1 1/4	R1 1/4	2	0,21
VLBP038	38	1 1/2	R1 1/2	2	0,21
VLBP050	50	2	R2	2	0,25
VLBP075	75	3	R3	2	0,50
VLBP100	100	4	R4	3	0,76

Plugs male/female

Coupling standard: **Federal Mil A-A-59326A / EN 14420-7 / DIN 2828**
 Material: **Aluminium, Stainless Steel, Brass, Polypropylene**
 For hose type: **POLIAX, CARBURITE, CARBOCORD, CHEMIOEL, FUCINO, WATER, IDRO, BEVERA**

Aluminium



Part-No.	Hose I.D. mm	Inch	Weight kg/pcs
VLPA013	13	1/2	0,02
VLPA019	19	3/4	0,03
VLPA025	25	1	0,05
VLPA032	32	1 1/4	0,07
VLPA038	38	1 1/2	0,12
VLPA050	50	2	0,16
VLPA063	63	2 1/2	0,22
VLPA075	75	3	0,28
VLPA100	100	4	0,50

Stainless Steel (AISI 316/1.4401) Male



Part-No.	Hose I.D. mm	Inch	Weight kg/pcs
VLPR013			0,06
VLPR019	19	3/4	0,08
VLPR025	25	1	0,13
VLPR032	32	1 1/4	0,25
VLPR038	38	1 1/2	0,32
VLPR050	50	2	0,46
VLPR063	63	2 1/2	0,67
VLPR075	75	3	0,93
VLPR100	100	4	1,59

Female

Part-No.	Hose I.D. mm	Inch	Weight kg/pcs
VLKR025S	25	1	0,43
VLKR038S	38	1 1/2	0,70
VLKR050S	50	2	0,88
VLKR075S	75	3	1,58

Brass



Part-No.	Hose I.D. mm	Inch	Weight kg/pcs
VLPM013	13	1/2	0,07
VLPM019	19	3/4	0,09
VLPM025	25	1	0,13
VLPM032	32	1 1/4	0,20
VLPM038	38	1 1/2	0,24
VLPM050	50	2	0,40
VLPM063	63	2 1/2	0,59
VLPM075	75	3	0,72
VLPM100	100	4	1,03

Polypropylene



Part-No.	Hose I.D. mm	Inch	Weight kg/pcs
VLPP013	13	1/2	0,01
VLPP019	19	3/4	0,02
VLPP025	25	1	0,02
VLPP032	32	1 1/4	0,04
VLPP038	38	1 1/2	0,05
VLPP050	50	2	0,08
VLPP075	75	3	0,22
VLPP100	100	4	0,26



aerospace
climate control
electromechanical
filtration
fluid & gas handling
hydraulics
pneumatics
process control
sealing & shielding



Thread Couplings

BSP



ENGINEERING YOUR SUCCESS.

b – Thread couplings (BSP)

b

Pressure range

Working pressure: 16 bar / 232 psi

Temperature range

-30°C (-22°F) up to +300°C (572°F)

Hose, coupling, assembly method and seal must be chosen in relation with the desired application and temperature range.

Materials

Thread couplings are available in the following materials:

- Brass
- Stainless steel ASTM A666 grade 316 / 1.4401

Thread

Thread type	Description	Standard	Name	Sealing
BSP	British standard pipe thread	EN ISO 228-1	G1	Parallel thread
				Sealed by gasket or o-ring
BSPT	British standard pipe taper thread	EN 10226-1/DIN 2999-1	R1	Conical thread.
				Sealing achieved by tightening up thread
NPT	National pipe taper thread (US)	ANSI B 1.20.1	NPT 1	Conical thread
				Sealing achieved by tightening up thread

Hose shank DIN 2817

Standard: Coupling: EN 14420-5 / DIN 2817; Hose shank: EN 14420-2 / DN 2817; Thread: EN ISO 228-1, BSP
 Material: Stainless Steel, Brass
 For hose type: POLIAX, DRINKPRESS, CARBOCORD, CARBURITE, CHEMIOEL, JETCORD, PRESS, MINIERA, IDRO

Assembly:

Safety Clamps	Worm Drive	Bolt clamps	Crimping
X			

Female



Stainless Steel (AISI 316/1.4401)

Part-No.	Hose I.D. mm	Inch	Thread	SW min. size mm	Weight kg/pcs
RRV013	13	1/2	G 1/2	24	0,10
RRV019	19	3/4	G 3/4	30	0,15
RRV025	25	1	G 1	36	0,16
RRV032	32	1 1/4	G 1 1/4	46	0,18
RRV038	38	1 1/2	G 1 1/2	55	0,29
RRV050	50	2	G 2	5	0,44
RRV063	63	2 1/2	G 2 1/2	85	0,75
RRV075	75	3	G 3	100	1,12
RRV100	100	4	G 4	125	3,90

Brass



Part-No.	Hose I.D. mm	Inch	Thread	SW min. size mm	Weight kg/pcs
RV013	13	1/2	G 1/2	24	0,06
RV019	19	3/4	G 3/4	30	0,10
RV025	25	1	G 1	36	0,13
RV032	32	1 1/4	G 1 1/4	46	0,20
RV038	38	1 1/2	G 1 1/2	55	0,38
RV050	50	2	G 2	65	0,42
RV063	63	2 1/2	G 2 1/2	85	0,68
RV075	75	3	G 3	100	0,98
RV100	100	4	G 4	125	3,60

Male



Stainless Steel (AISI 316/1.4401)

Part-No.	Hose I.D. mm	Inch	Thread	SW min. size mm	Weight kg/pcs
RRM013	13	1/2	G 1/2	22	0,07
RRM019	19	3/4	G 3/4	27	0,10
RRM025	25	1	G 1	36	0,15
RRM032	32	1 1/4	G 1 1/4	46	0,21
RRM038	38	1 1/2	G 1 1/2	55	0,29
RRM050	50	2	G 2	65	0,43
RRM063	63	2 1/2	G 2 1/2	85	0,69
RRM075	75	3	G 3	100	0,91
RRM100	100	4	G 4	125	1,76

Brass



Part-No.	Hose I.D. mm	Inch	Thread	SW min. size mm	Weight kg/pcs
RM013	13	1/2	G 1/2	22	0,07
RM019	19	3/4	G 3/4	27	0,10
RM025	25	1	G 1	36	0,15
RM032	32	1 1/4	G 1 1/4	46	0,26
RM038	38	1 1/2	G 1 1/2	55	0,35
RM050	50	2	G 2	65	0,46
RM063	63	2 1/2	G 2 1/2	85	0,72
RM075	75	3	G 3	100	0,91
RM100	100	4	G 4	125	1,93

Serrated hose shank

Standard: Thread: EN ISO 228-1, BSP
 Material: Stainless Steel, Brass
 For hose type: POLIAX, DRINKPRESS, CARBOCORD, CARBURITE, CHEMIOEL, JETCORD, PRESS, MINIERA, BEVERA, WATER, IDRO

Assembly:

Safety Clamps	Worm Drive	Bolt clamps	Crimping
	X	X	

Female

Stainless Steel (AISI 316/1.4401)



Part-No.	Hose I.D. mm	Inch	Thread	SW min. size mm	Weight kg/pcs
R2R013	13	1/2	G 1/2	24	0,09
R2R019	19	3/4	G 3/4	30	0,10
R2R025	25	1	G 1	36	0,16
R2R032	32	1 1/4	G 1 1/4	46	0,20
R2R038	38	1 1/2	G 1 1/2	55	0,39
R2R050	50	2	G 2	65	0,44
R2R065	63	2 1/2	G 2 1/2	85	0,82
R2R075	75	3	G 3	100	0,94

Brass



Part-No.	Hose I.D. mm	Inch	Thread	SW min. size mm	Weight kg/pcs
2R013	13	1/2	G 1/2	24	0,05
2R019	19	3/4	G 3/4	30	0,07
2R025	25	1	G 1	36	0,09
2R032	32	1 1/4	G 1 1/4	46	0,16
2R038	38	1 1/2	G 1 1/2	55	0,20
2R050	50	2	G 2	65	0,31
2R065	63	2 1/2	G 2 1/2	85	0,55
2R075	75	3	G 3	100	0,54
2R100	100	4	G 4	125	1,89

Male

Stainless Steel (AISI 316/1.4401)



Part-No.	Hose I.D. mm	Inch	Thread	SW min. size mm	Weight kg/pcs
R1R013	13	1/2	G 1/2	22	0,07
R1R019	19	3/4	G 3/4	27	0,10
R1R025	25	1	G 1	36	0,16
R1R032	32	1 1/4	G 1 1/4	46	0,30
R1R038	38	1 1/2	G 1 1/2	55	0,38
R1R050	50	2	G 2	65	0,54
R1R065	63	2 1/2	G 2 1/2	85	0,87
R1R075	75	3	G 3	95	0,96

Brass



Part-No.	Hose I.D. mm	Inch	Thread	SW min. size mm	Weight kg/pcs
1R013	13	1/2	G 1/2	22	0,08
1R019	19	3/4	G 3/4	27	0,11
1R025	25	1	G 1	36	0,15
1R032	32	1 1/4	G 1 1/4	46	0,26
1R038	38	1 1/2	G 1 1/2	55	0,27
1R050	50	2	G 2	65	0,50
1R065	63	2 1/2	G 2 1/2	85	0,92
1R075	75	3	G 3	100	1,00
1R100	100	4	G 4	125	1,89

b



aerospace
climate control
electromechanical
filtration
fluid & gas handling
hydraulics
pneumatics
process control
sealing & shielding



European Air Couplings



ENGINEERING YOUR SUCCESS.

c – European Air Couplings

Working pressure

10 bar / 145 psi

Working temperature

-30°C (-22°F) up to +120°C (+248°F)

Hose, coupling, assembly method and seal must be chosen in relation with the desired application and temperature range.

Material

– Galvanized steel

Features

- Designed for air and water applications, not suitable for steam.
- Standard claw distance 42 mm
- Serrated hose shank, also available with safety collar

Threads

- Male: EN ISO 228-1 (BSP)
- Female: EN ISO 228-1 (BSP)

C

Threaded Couplings

Claw distance: 42 mm
 Working pressure: **10 bar / 145 psi**
 Material: **Galvanized steel**
 For hose type: **PRESS, PRESSCORD, AIR SP 318, AIRSTATION 2000, CARBOPRESS, OILPRESS, PYTHON**
 Assembly: **Thread DIN 3489**

Male Thread VBA



Steel

Part-No.	Inch	Thread DIN 2999	Weight kg/pcs
EAM006	1/4	R 1/4	0,14
EAM010	3/8	R 3/8	0,15
EAM013	1/2	R 1/2	0,15
EAM019	3/4	R 3/4	0,18
EAM025	1	R 1	0,19
EAM032	1 1/4	R 1 1/4	0,26

Female Thread VBI



Steel

Part-No.	Inch	Thread	Weight kg/pcs
EAF006	1/4	G 1/4	0,13
EAF010	3/8	G 3/8	0,14
EAF013	1/2	G 1/2	0,14
EAF019	3/4	G 3/4	0,15
EAF025	1	G 1	0,18
EAF032	1 1/4	G 1 1/4	0,25

Serrated hose shank

Claw distance: 42 mm
 Working pressure: 10 bar / 145 psi
 Material: Galvanized steel
 For hose type: PRESS, PRESSCORD, AIRSTATION 2000, CARBORESS, OILPRESS, PYTHON

Assembly:

Safety Clamps	Worm Drive	Bolt clamps	Crimping
	X		

Hose shank



Steel

Part-No.	Hose I.D. mm	Inch	Weight kg/pcs
EAS010	10	3/8	0,15
EAS013	13	1/2	0,16
EAS016	16	5/8	0,15
EAS019	19	3/4	0,18
EAS025	25	1	0,21
EAS032	32	1 1/4	0,22

Hose shank and collar



Steel

Part-No.	Hose I.D. mm	Inch	Weight kg/pcs
EASK010	10	3/8	0,13
EASK013	13	1/2	0,19
EASK019	19	3/4	0,20
EASK025	25	1	0,22

Cap



Steel

Part-No.	Weight kg/pcs
EAK	0,15

Profiled seal



NBR / black

Part-No.	O.D. mm +0,1 / -0,2	I.D.	Height mm +0,2 / -0,1	Box pieces	Weight kg/pcs
EAX	34,0	20,0	11,0	50	0,006



aerospace
climate control
electromechanical
filtration
fluid & gas handling
hydraulics
pneumatics
process control
sealing & shielding



GK Couplings



ENGINEERING YOUR SUCCESS.

d – GK Couplings

Working pressure

20 bar / 290 psi

Working temperature

-30 °C (-22 °F) up to +120 °C (+248 °F)

Hose, coupling, assembly method and seal must be chosen in relation with the desired application and temperature range.

Material

– Brass 2.0401 – Ms 58, hot forged

Features

- Designed water applications in gardening, agriculture and industrial service.
- Standard claw distance 40 mm
- Serrated hose shank for assembling with worm or bolt clamps

Threads

- Male: EN ISO 228-1 (BSP)
- Female: EN ISO 228-1 (BSP)

d

GK Couplings

Claw distance: 40 mm
 Working pressure: 20 bar / 290 psi
 Material: Brass
 For hose type: PRESS, PRESCORD, JUMBO, WASSERPRESS, AQUAPRESS, PYTHON, VARIOPRESS

Assembly:

Safety Clamps	Worm Drive	Bolt clamps	Crimping
	X		

Brass



Part-No.	Hose I.D. mm	Inch	Weight kg/pcs
GKS010	10	3/8	0,07
GKS013	13	1/2	0,07
GKS016	16	1/2	0,08
GKS019	19	1/2	0,08
GKS025	25	1	0,10
GKS032	32	1 1/4	0,14
GKS038	32	1 1/4	0,18

Female Thread

Brass



Part-No.	Hose I.D. mm	Inch	Thread	Weight kg/pcs
GKF010	10	3/8	G 3/8	0,07
GKF013	13	1/2	G 1/2	0,07
GKF019	19	3/4	G 3/4	0,08
GKF025	25	1	G1	0,08
GKF032	32	1 1/4	G 1.1/4	0,11
GKF038	38	1 1/2	G 1.1/2	0,13

Male Thread

Brass



Part-No.	Hose I.D. mm	Inch	Thread	Weight kg/pcs
GKM010	10	3/8	G 3/8	0,07
GKM013	13	1/2	G 1/2	0,07
GKM019	19	3/4	G 3/4	0,07
GKM025	25	1	G1	0,08
GKM032	32	1 1/4	G 1.1/4	0,10
GKM038	38	1 1/2	G 1.1/2	0,14

Coupling Cap

Brass



Part-No.	Weight kg/pcs
GKK	0,09

Seal

Brass



Part-No.	Material	Color	O.D. Ø mm	I.D. Ø mm	Height mm	Box quantity	Weight kg/pcs
GKXB	NBR	black	35,0	24,0	12,0	50	0,005
GKXV	FPM	green	35,0	24,0	12,0	50	0,009



aerospace
climate control
electromechanical
filtration
fluid & gas handling
hydraulics
pneumatics
process control
sealing & shielding



Tankwagen Couplings

TW



ENGINEERING YOUR SUCCESS.

e – TW „Tankwagen“ couplings

Working pressure

25 bar / 362 psi

Working temperature

-30 °C (-22 °F) up to +120 °C (+248 °F)

Hose, coupling, assembly method and seal must be chosen in relation with the desired application and temperature range.

Materials

- Brass CW1617N, forged
- Stainless steel AISI 316 / 1.4408, investment casting

Features

- TW coupling dimensions are specified in the EN 14420-6 and the DIN 28450.
- All TW couplings manufactured in compliance with this standard are interchangeable.

Threads

Female: EN ISO 228-1 (BSP)

Smooth Hose Shank

Standard: Hose shank EN 14420-2 / DIN 2817
 Material: Stainless Steel. Steel
 For hose type: POLIAX, CARBURITE, CHEMIOEL EN 12115, PYTHON, VARIOPRESS
 Assembly:

Safety Clamps	Worm Drive	Bolt clamps	Crimping
X			

Female
with locking lever



Stainless Steel (AISI 316 - 1.4408)

Part-No.	Hose I.D. mm	Inch	Weight kg/pcs
MKSTRR050	50	2	1,09
MKSTRR080	75	3	2,21



Brass

Part-No.	Hose I.D. mm	Inch	Weight kg/pcs
MKST050	50	2	1,20
MKST080	75	3	2,37

Male



Stainless Steel (AISI 316 - 1.4408)

Part-No.	Hose I.D. mm	Inch	Weight kg/pcs
VKSTR050	50	2	0,78
VKSTR080	75	3	1,65



Brass

Part-No.	Hose I.D. mm	Inch	Weight kg/pcs
VKST050	50	2	0,76
VKST080	75	3	1,69

Female Threaded

Female
with locking lever



Stainless Steel (AISI 316 - 1.4408)

Part-No.	Hose I.D. mm	Inch	Thread	Weight kg/pcs
MKRR050	50	2	G2	0,63
MKRR080	75	3	G3	1,30

Brass



Part-No.	Hose I.D. mm	Inch	Thread	Weight kg/pcs
MK050	50	2	G2	0,74
MK080	75	3	G3	1,46

Male
with thread seal



Stainless Steel (AISI 316 - 1.4408)

Part-No.	Hose I.D. mm	Inch	Thread	Weight kg/pcs
VKR050	50	2	G2	0,32
VKR080	80	3	G3	0,74

Brass



Part-No.	Hose I.D. mm	Inch	Thread	Weight kg/pcs
VK050	50	2	G2	0,30
VK080	80	3	G3	0,78

e

Locking Ring with Lever

Stainless Steel (AISI 316 - 1.4408)



Part-No.	Hose I.D. mm	Inch	Weight kg/pcs
MKHR050	50	2	0,43
MKHR080	75	3	0,91

Brass



Part-No.	Hose I.D. mm	Inch	Weight kg/pcs
MKH050	50	2	0,51
MKH080	75	3	0,93

Crown Part Female Threaded

Stainless Steel (AISI 316 - 1.4408)



Part-No.	Hose I.D. mm	Inch	Thread	Weight kg/pcs
MKVR050	50	2	G2	0,20
MKVR080	75	3	G3	0,49

Brass



Part-No.	Hose I.D. mm	Inch	Thread	Weight kg/pcs
MKV050	50	2	G2	0,23
MKV080	75	3	G3	0,55

Dust Cap

Stainless Steel (AISI 316 - 1.4408)



Part-No.	Hose I.D. mm	Inch	Weight kg/pcs
MBR050	50	2	0,35
MBR080	75	3	0,81

Brass



Part-No.	Hose I.D. mm	Inch	Weight kg/pcs
MB050	50	2	0,37
MB080	75	3	0,88

e

Dust Plug

Stainless Steel (AISI 316 - 1.4408)



Part-No.	Hose I.D. mm	Inch	Weight kg/pcs
VBR050	50	2	0,30
VBR080	75	3	0,71

Brass



Part-No.	Hose I.D. mm	Inch	Weight kg/pcs
VB050	50	2	0,36
VB080	75	3	0,89



aerospace
climate control
electromechanical
filtration
fluid & gas handling
hydraulics
pneumatics
process control
sealing & shielding



Guillemin



ENGINEERING YOUR SUCCESS.

f – Guillemin

Working pressure

16 bar / 230 psi

Working temperature

-20 °C (-4 °F) up to +65 °C (+149 °F)

Hose, coupling, assembly method and seal must be chosen in relation with the desired application and temperature range.

Materials

- Aluminium, heat treated
- Stainless steel AISI 316 / 1.4401

Features

- For suction and delivery of liquids, powders and granules in compliance with EN 1440-8 / NF E 29-572.
- Applications like load and unload of road tankers, silos and wagons.
- Guillemin couplings must not be used for steam or gas applications.

f

Symmetric Couplings

Working pressure: **16 bar / 230 psi**
 Material: **Aluminium, Stainless Steel**
 For hose type: **POLIAX, CARBURITE, CHEMIOEL, CEMENT, BEVERA, IDRO, CARBUREX**

Assembly:

Safety Clamps	Worm Drive	Bolt clamps	Crimping
X			

Aluminium



Part-No.	Hose I.D. mm	Inch	Collar	Weight kg/pcs
LGSG038	38	1 1/2	-	0,17
LGSG050	50	2	x	0,33
LGSG055	50	2	-	0,38
LGSG075	75	3	x	0,77
LGSG090	75	3	-	0,85
LGSG100	100	4	x	1,33

Stainless Steel (AISI 316/1.4401)



Part-No.	Hose I.D. mm	Inch	Collar	Weight kg/pcs
RGSG038	38	1 1/2	x	0,52
RGSG050	50	2	x	0,93
RGSG055	50	2	-	0,87
RGSG065	63	2 1/2	x	1,05
RGSG075	75	3	x	2,27
RGSG100	100	4	x	3,31



aerospace
climate control
electromechanical
filtration
fluid & gas handling
hydraulics
pneumatics
process control
sealing & shielding



Petrol Pump Couplings



ENGINEERING YOUR SUCCESS.

g – Petrol Pump Couplings

Working pressure

Suction: max. -0.8 bar / 11.6 psi

Pressure: max. 20 bar / 232 psi

Working temperature

-20 °C (-4 °F) up to +65 °C (+149 °F)

Hose, coupling, assembly method and seal must be chosen in relation with the desired application and temperature range.

Material

– Brass CW614N – EN 12420

Features

- Manufactured in compliance with the EN 14424
- Reusable fitting for the use with rubber hoses, in fuel and gas applications.

Threads

Male part

Male thread – connection side: EN 10226-1, BSPT EN ISO 228-1, BSP and ANSI B.1.20.1

Male thread – hose side: Metric ISO thread complying with DIN 13

Female thread ferrule: Metric ISO thread complying with DIN 13

Female part

Female thread – connection side: EN ISO 228-1, BSP

Male thread – hose side: Metric ISO thread complying with DIN 13

Female thread ferrule: Metric ISO thread complying with DIN 13

Petrol pump Couplings

Standard: Male thread hose side and female thread ferrule: **ISO metric DIN 13**
 Male thread connection side: **EN 10226-1, BSPT**
 Female thread connection side: **EN ISO 228-1, BSP**

Material: **Brass**

For hose type: **CARBOPRESS, OILPRESS**

Female



Brass

Part-No.	Hose I.D. mm	Female Thread nut	Male Thread Hose side	Female Thread Ferrule	Weight kg/pcs
BPK21305	13 x 5	G 1/2	M 16 x 1,0		0,13
BPK2151905	15 x 5	G 3/4	M 19 x 1,0		0,14
BPK21904	19 x 4	G 3/4	M 22 x 1,5		0,15
BPK21905	19 x 5	G 3/4	M 22 x 1,5		0,16
BPK21906	19 x 6	G 3/4	M 22 x 1,5		0,19
BPK2192504	19 x 4	G 1	M 22 x 1,5		0,17
BPK2192505	19 x 5	G 1	M 22 x 1,5		0,18
BPK2192506	19 x 6	G 1	M 22 x 1,5		0,19
BPK22505	25 x 5	G 1	M 28 x 1,5		0,21
BPK22506	25 x 6	G 1	M 28 x 1,5		0,23

Male



Brass

Part-No.	Hose I.D. mm	Male Thread Connection side	Male Thread Hose side	Female Thread Ferrule	Weight kg/pcs
BPK11305T	13 x 5	R 1/2	M 16 x 1,0		0,13
BPK1151905T	15 x 5	R 3/4	M 19 x 1,0		0,19
BPK11904T	19 x 4	R 3/4	M 22 x 1,5		0,16
BPK11905T	19 x 5	R 3/4	M 22 x 1,5		0,17
BPK11906T	19 x 6	R 3/4	M 22 x 1,5		0,20
BPK1192504T	19 x 4	R 1	M 22 x 1,5		0,19
BPK1192505T	19 x 5	R 1	M 22 x 1,5		0,20
BPK1192506T	19 x 6	R 1	M 22 x 1,5		0,21
BPK12505T	25 x 5	R 1	M 28 x 1,5		0,25
BPK12506T	25 x 6	R 1	M 28 x 1,5		0,27



aerospace
climate control
electromechanical
filtration
fluid & gas handling
hydraulics
pneumatics
process control
sealing & shielding

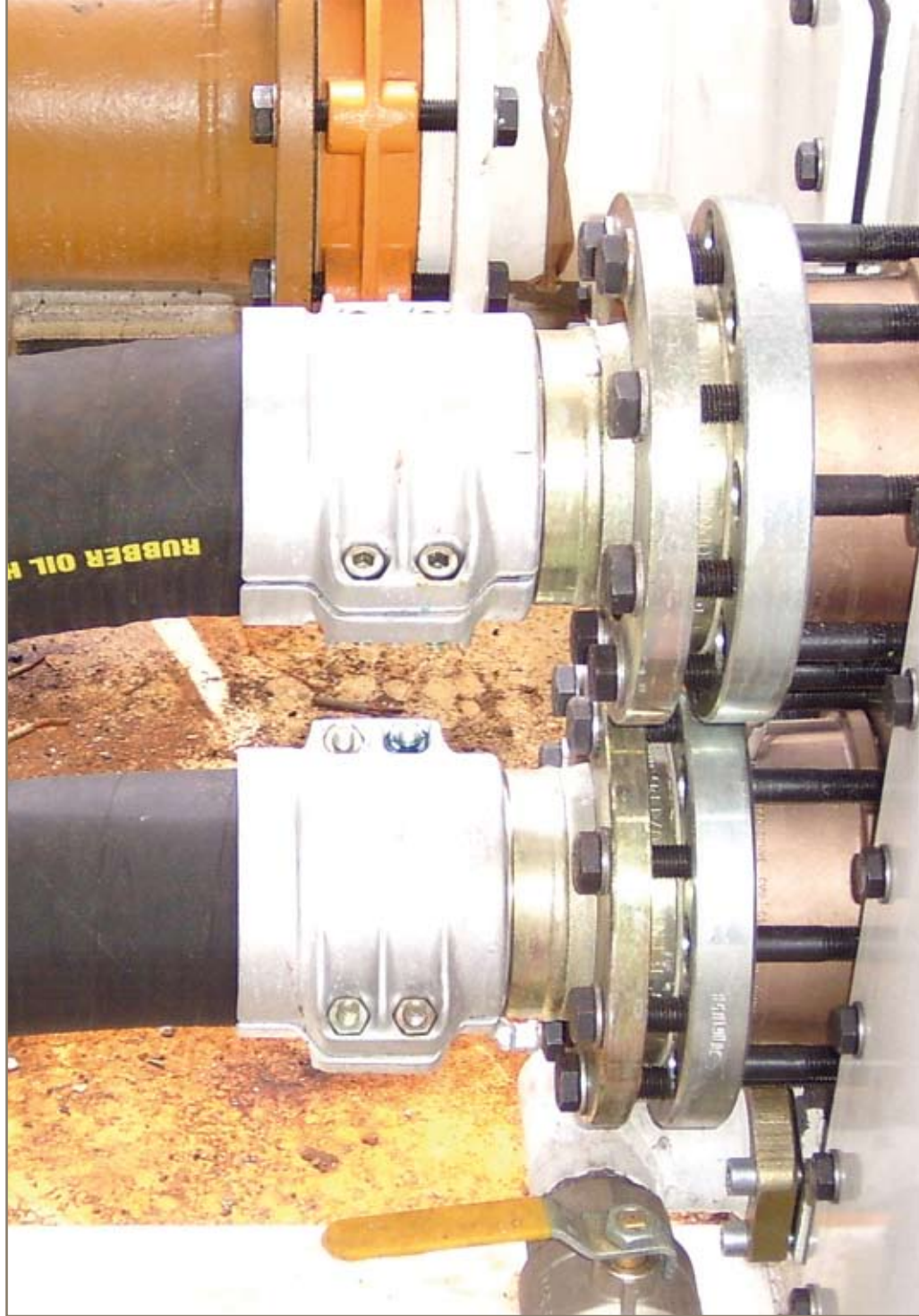

Flange



ENGINEERING YOUR SUCCESS.

h – Flange

Working pressure

PN 10/16 – 150 lbs

Working temperature

-20 °C (-4 °F) up to +65 °C (+149 °F)

Hose, coupling, assembly method and seal must be chosen in relation with the desired application and temperature range.

Materials

- Galvanized steel
- Stainless steel AISI 316 / 1.4401

Features

- Swivel or flange couplings with smooth hose shank, complying with the EN 14420-4 and DIN 2817
- Flange-to-flange connections should preferably fitted with at least one swivel flange to prevent twisting of the hose during assembling.
- Flange connections need to be face-sealed with flat gaskets.

h

Swivel Flanges

Standard: EN 1092-1 / 04 A, DIN 2673 PN 10, DIN 2674 PN 16, DIN 2634 PN 25 and DIN 2635 PN 40, ASTM / A 182 / ANSI B16.5, ASA 150 lbs

Material: Steel, Stainless Steel

For hose type: POLIAX, CARBURITE, CHEMIOEL, JETCORD, BEVERA, IDRO

Assembly:

Safety Clamps	Worm Drive	Bolt clamps	Crimping
X			

Steel (galvanized)



Part-No.	Hose I.D. mm	Inch	Pressure Class	Weight kg/pcs
FLGP4013	13	1/2	EN-DIN PN 25/40	0,92
FLGP4019	19	3/4	EN-DIN PN 25/40	1,17
FLGP4025	25	1	EN-DIN PN 25/40	1,94
FLGP4032	32	1 1/4	EN-DIN PN 25/40	2,82
FLGP4038	38	1 1/2	EN-DIN PN 25/40	3,28
FLGP4050	50	2	EN-DIN PN 25/40	4,61
FLGP4063	63	2 1/2	EN-DIN PN 25/40	6,16
FLGP4075	75	3	EN-DIN PN 25/40	8,33
FLGP40100	100	4	EN-DIN PN 25/40	9,88

Stainless Steel (AISI 316/1.4401)



Part-No.	Hose I.D. mm	Inch	Pressure Class	Weight kg/pcs
RRFLGP4013	13	1/2	EN-DIN PN 25/40	1,01
RRFLGP4019	19	3/4	EN-DIN PN 25/40	1,61
RRFLGP4025	25	1	EN-DIN PN 25/40	1,87
RRFLGP4032	32	1 1/4	EN-DIN PN 25/40	2,78
RRFLGP4038	38	1 1/2	EN-DIN PN 25/40	3,33
RRFLGP4050	50	2	EN-DIN PN 25/40	4,65
RRFLGP4063	63	2 1/2	EN-DIN PN 25/40	6,17
RRFLGP4075	75	3	EN-DIN PN 25/40	8,31
RRFLGP4100	100	4	EN-DIN PN 25/40	9,58

Steel (galvanized)



Part-No.	Hose I.D. mm	Inch	Pressure Class	Weight kg/pcs
FLP013	13	1/2	EN-DIN PN 10/16	0,82
FLP019	19	3/4	EN-DIN PN 10/16	1,10
FLP025	25	1	EN-DIN PN 10/16	1,53
FLP032	32	1 1/4	EN-DIN PN 10/16	2,06
FLP038	38	1 1/2	EN-DIN PN 10/16	2,68
FLP050	50	2	EN-DIN PN 10/16	3,22
FLP063	63	2 1/2	EN-DIN PN 10/16	4,18
FLP075	75	3	EN-DIN PN 10/16	5,29
FLP100	100	4	EN-DIN PN 10/16	7,01
FLP125	125	5	EN-DIN PN 10/16	14,19
FLP150	150	6	EN-DIN PN 10/16	17,72

Stainless Steel (AISI 316/1.4401)



Part-No.	Hose I.D. mm	Inch	Pressure Class	Weight kg/pcs
RRFLP013	13	1/2	EN-DIN PN 10/16	0,79
RRFLP019	19	3/4	EN-DIN PN 10/16	1,10
RRFLP025	25	1	EN-DIN PN 10/16	1,49
RRFLP032	32	1 1/4	EN-DIN PN 10/16	2,12
RRFLP038	38	1 1/2	EN-DIN PN 10/16	2,50
RRFLP050	50	2	EN-DIN PN 10/16	3,43
RRFLP063	63	2 1/2	EN-DIN PN 10/16	3,85
RRFLP075	75	3	EN-DIN PN 10/16	5,25
RRFLP100	100	4	EN-DIN PN 10/16	6,02
RRFLP125	125	5	EN-DIN PN 10/16	9,13
RRFLP150	150	6	EN-DIN PN 10/16	11,83

Rigid Flanges

Standard: EN 1092-1 / 04 A, DIN 2673 PN 10, DIN 2674 PN 16, DIN 2634 PN 25 and DIN 2635 PN 40, ASTM / A 182 / ANSI B16.5, ASA 150 lbs

Material: Steel, Stainless Steel

For hose type: POLIAX, CARBURITE, CHEMIOEL, JETCORD, BEVERA, IDRO

Assembly:

Safety Clamps	Worm Drive	Bolt clamps	Crimping
X			

Steel (galvanized)



Part-No.	Hose I.D. mm	Inch	Pressure Class	Weight kg/pcs
FVG013	13	1/2	EN-DIN PN 10/16	0,69
FVG019	19	3/4	EN-DIN PN 10/16	1,00
FVG025	25	1	EN-DIN PN 10/16	1,23
FVG032	32	1 1/4	EN-DIN PN 10/16	1,80
FVG038	38	1 1/2	EN-DIN PN 10/16	2,01
FVG050	50	2	EN-DIN PN 10/16	2,80
FVG063	63	2 1/2	EN-DIN PN 10/16	3,47
FVG075	75	3	EN-DIN PN 10/16	4,26
FVG100	100	4	EN-DIN PN 10/16	5,67
FVG125	125	5	EN-DIN PN 10/16	8,73
FVG150	150	6	EN-DIN PN 10/16	11,64

Stainless Steel (AISI 316/1.4401)



Part-No.	Hose I.D. mm	Inch	Pressure Class	Weight kg/pcs
RFVG013	13	1/2	EN-DIN PN 10/16	0,70
RFVG019	19	3/4	EN-DIN PN 10/16	1,01
RFVG025	25	1	EN-DIN PN 10/16	1,24
RFVG032	32	1 1/4	EN-DIN PN 10/16	1,83
RFVG038	38	1 1/2	EN-DIN PN 10/16	2,03
RFVG050	50	2	EN-DIN PN 10/16	2,79
RFVG063	63	2 1/2	EN-DIN PN 10/16	3,47
RFVG075	75	3	EN-DIN PN 10/16	4,33
RFVG100	100	4	EN-DIN PN 10/16	5,67
RFVG125	125	5	EN-DIN PN 10/16	8,63
RFVG150	150	6	EN-DIN PN 10/16	11,99

Steel (galvanized)



Part-No.	Hose I.D. mm	Inch	Pressure Class	Weight kg/pcs
FVP013	13	1/2	EN-DIN PN 10/16	0,70
FVP019	19	3/4	EN-DIN PN 10/16	1,02
FVP025	25	1	EN-DIN PN 10/16	1,23
FVP032	32	1 1/4	EN-DIN PN 10/16	1,82
FVP038	38	1 1/2	EN-DIN PN 10/16	2,01
FVP050	50	2	EN-DIN PN 10/16	2,79
FVP063	63	2 1/2	EN-DIN PN 10/16	3,70
FVP075	75	3	EN-DIN PN 10/16	4,26
FVP100	100	4	EN-DIN PN 10/16	5,68
FVP125	125	5	EN-DIN PN 10/16	8,51
FVP150	150	6	EN-DIN PN 10/16	11,29

Stainless Steel (AISI 316/1.4401)



Part-No.	Hose I.D. mm	Inch	Pressure Class	Weight kg/pcs
RFVP013	13	1/2	EN-DIN PN 10/16	0,70
RFVP019	19	3/4	EN-DIN PN 10/16	1,01
RFVP025	25	1	EN-DIN PN 10/16	1,24
RFVP032	32	1 1/4	EN-DIN PN 10/16	1,83
RFVP038	38	1 1/2	EN-DIN PN 10/16	2,03
RFVP050	50	2	EN-DIN PN 10/16	2,79
RFVP063	63	2 1/2	EN-DIN PN 10/16	3,47
RFVP075	75	3	EN-DIN PN 10/16	4,33
RFVP100	100	4	EN-DIN PN 10/16	5,67
RFVP125	125	5	EN-DIN PN 10/16	8,63
RFVP150	150	6	EN-DIN PN 10/16	11,99



aerospace
climate control
electromechanical
filtration
fluid & gas handling
hydraulics
pneumatics
process control
sealing & shielding



Steam Couplings



ENGINEERING YOUR SUCCESS.

i – Steam Couplings

Working pressure

18 bar / 261 psi

Working temperature

Saturated steam: 210 °C (410 °F)

Hot water: 120 °C (248 °F)

Hose, coupling, assembly method and seal must be chosen in relation with the desired application and temperature range.

Material

- Brass CW614N / EN 12420
- Galvanized Steel 95MnPb28 / 1.0718

Features

- Manufactured in compliance with the EN 14423 / DIN 2826
- Other assembly types like standard safety clamps (EN14420-3 / DIN 2817), bolt clamps or crimp ferrules must not be used at any time.

Threads

Male thread: EN 10226-1 / DIN 2999, BSPT ANSI B.1.20.1

Female thread: EN ISO 228-1, BSP ANSI B.1.20.1

Safety Warning

Steam applications can be hazardous; therefore assembling should only be carried out by trained personnel. Use only couplings with steam safety clamps (EN 14423 / DIN 2826). Check coupling tightness before every utilisation. Drain hose after use. When not in use, store the hose on a flat surface (shelve) and never hang from a hook. Steam hoses gradually decrease in their performances during service life. Consequently, they need to be regularly inspected by trained personnel wearing adequate protective cloths overall, including eye protection.

Steam Couplings

Thread standard: EN 10226-1 / DIN 2999, BSPT; ANSI B 1.20.1, NPT; EN ISO 228-1, BSP
 Material: Steel, Brass
 For hose type: VAPORE 164 EN ISO 6134, VIGOR 1 EN ISO 6134, VIGOR 2 EN ISO 6134

Assembly:

Safety Clamps	Worm Drive	Bolt clamps	Crimping
X			

Female



Steel (AISI 304/1.4301)

Part-No.	Hose I.D. mm	Inch	Thread	Weight kg/pcs
RVSS013	13	1/2	G 1/2	0,11
RVSS019	19	3/4	G 3/4	0,18
RVSS025	25	1	G 1	0,26
RVSS032	32	1 1/4	G 1 1/4	0,39
RVSS038	38	1 1/2	G 1 1/2	0,48
RVSS050	50	2	G 2	0,80

Brass



Part-No.	Hose I.D. mm	Inch	Thread	Weight kg/pcs
RVSM013	13	1/2	G 1/2	0,12
RVSM019	19	3/4	G 3/4	0,18
RVSM025	25	1	G 1	0,28
RVSM032	32	1 1/4	G 1 1/4	0,44
RVSM038	38	1 1/2	G 1 1/2	0,54
RVSM050	50	2	G 2	0,85

Male



Steel (AISI 304/1.4301)

Part-No.	Hose I.D. mm	Inch	Thread	Weight kg/pcs
RMSS013	13	1/2	R 1/2	0,10
RMSS019	19	3/4	R 3/4	0,17
RMSS025	25	1	R 1	0,26
RMSS032	32	1 1/4	R 1 1/4	0,40
RMSS038	38	1 1/2	R 1 1/2	0,51
RMSS050	50	2	R 2	0,80

Brass



Part-No.	Hose I.D. mm	Inch	Thread	Weight kg/pcs
RMMS013	13	1/2	R 1/2	0,12
RMMS019	19	3/4	R 3/4	0,18
RMMS025	25	1	R 1	0,28
RMMS032	32	1 1/4	R 1 1/4	0,43
RMMS038	38	1 1/2	R 1 1/2	0,52
RMMS050	50	2	R 2	0,89



aerospace
climate control
electromechanical
filtration
fluid & gas handling
hydraulics
pneumatics
process control
sealing & shielding



Sandblast Couplings



ENGINEERING YOUR SUCCESS.

j – Sandblast Couplings

Working pressure

10 bar (150 psi)

Working temperature

-30 °C (-22 °F) up to +70 °C (+158 °F)

Hose, coupling, assembly method and seal must be chosen in relation with the desired application and temperature range.

Materials

- Malleable iron, zinc plated
- Nylon

Features

- Hose assembly is completed inside the coupling, hose is fixed by screws from outside
- Standard claw distance 58 mm for all sizes
- Couplings of malleable iron are very robust, while nylon couplings are used for weight reasons

Threads

- Female BSP - EN ISO 228-1
- Female coarse thread 50 mm - ANSI B1.1

Sandblast couplings

Material: **Malleable iron, zinc plated or nylon**
 For hose type: **LIBECCIO**
 Claw distance: **58 mm**
 Assembly:

Safety Clamps	Worm Drive	Bolt clamps	Crimping



Part-No.	Hose I.D. x wallthickness	Height	Width	Weight kg/pcs
SBS19	19 x 6 mm	100	63	0,40
SBS25	25 x 7 mm	93	87	0,48
SBS32	32 x 8 mm	92	87	0,57
SBS38	38 x 9 mm	129	87	0,78
SBS40	40 x 10 mm	150	87	0,89



Part-No.	Hose I.D. x wallthickness	Height	Width	Weight kg/pcs
SBS32T	G 1 1/4"	55	87	0,39
SBS38T	G 1 1/2"	55	87	0,34
SBS50T	G 2"	84	87	0,55
SBS50MT	Coarse thread 50 mm	55	87	0,32



Part-No.	Hose I.D. x wallthickness	Thread	Height	Width	Weight kg/pcs
SBNA32	32 x 8 mm	G 1 1/4"	130	57	0,25
SBNA50	32 x 8 mm	Coarse thread 50 mm	130	57	0,23



Part-No.	Hose I.D. x wallthickness	Height	Width	Weight kg/pcs
SBN19	19 x 6 mm	110	51	0,19
SBN25	25 x 7 mm	110	51	0,17
SBN32	32 x 8 mm	136	60	0,22
SBN38	38 x 9 mm	136	67	0,24
SBN40	40 x 10 mm	136	71	0,22



Part-No.	Hose I.D. x wallthickness	Height	Width	Weight kg/pcs
SBN32T	G 1 1/4"	63	61	0,13
SBN50MT	Coarse thread 50 mm	63	61	0,11



Part-No.	Hose I.D. x wallthickness	Thread	Height	Width	Weight kg/pcs
SBNN19M	19 x 7 mm	Coarse thread 50 mm	100	49	0,115
SBNN25M	25 x 7 mm	Coarse thread 50 mm	100	93	0,93
SBNN32M	32 x 8 mm	Coarse thread 50 mm	120	59	0,15
SBNN38M	38 x 9 mm	Coarse thread 50 mm	128	68	0,156
SBNN19	19 x 7 mm	G 1 1/4"	100	51	0,109
SBNN25	25 x 7 mm	G 1 1/4"	100	51	0,102
SBNN32	32 x 8 mm	G 1 1/4"	128	59	0,154
SBNN38	38 x 9 mm	G 1 1/4"	128	66	0,166



aerospace
climate control
electromechanical
filtration
fluid & gas handling
hydraulics
pneumatics
process control
sealing & shielding



Mortar Couplings



ENGINEERING YOUR SUCCESS.

k – Mortar Couplings

Working pressure

Max. 50 bar (725 psi), max. 25 bar (363 psi) with band clamps

Working temperature

-30 °C (-22 °F) up to +70 °C (+158 °F)

Hose, coupling, assembly method and seal must be chosen in relation with the desired application and temperature range.

Materials

– Malleable iron, zinc plated

Features

- The principle of Mortar couplings is similar to Kamlock, but not interchangeable
- For mortar and plaster lines on pumps, spraying devices, plastering machines, etc.
- Couplings of malleable iron, very robust, with maximum bore for free flow

Threads

- Female BSP - EN ISO 228-1
- Male BSP - EN ISO 228-1

Note

Please note the two different systems used in the market. Only same type-size and same system are interchangeable!

k

Mortar Couplings

Material: **Malleable iron, zinc plated or nylon**
 For hose type: **INTONACATRICI**
 Construction: **System 22, not interchangeable with system 23.5**
 Assembly:

Safety Clamps	Worm Drive	Bolt clamps	Crimping
		X	



Part-No.	Hose I.D.	Height	Width	Head I.D.	Weight kg/pcs
MFHS25	25	120	55	35.5	0,48
MFHS35	35	132	77	51	0,80
MFHS38	38	146	77	51	0,90
MFHS42	42	144	84	54	0,96
MFHS50	50	140	94	64	1,20
MFHS65	65	185	100	74	2,17



Part-No.	Thread	Height	Width	Head I.D.	Weight kg/pcs
MFFT2535	G 1"	70	55	35.5	0,65
MFFT2551	G 1"	74	77	51	0,77
MFFT3251	G 1 1/4"	74	77	51	0,65
MFFT3851	G 1 1/2"	74	77	51	0,77
MFFT3854	G 1 1/2"	66	84	54	0,73
MFFT5064	G 2"	79	94	64	0,99
MFFT6574	G 2 1/2"	81	105	74	1,03



Part-No.	Thread	Height	Width	Head I.D.	Weight kg/pcs
MFMT2535	G 1"	91	55	35.5	0,49
MFMT3251	G 1 1/4"	93	77	51	0,79
MFMT3854	G 1 1/2"	98	84	54	0,94
MFMT5064	G 2"	113	94	64	1,42
MFMT6564	G 2 1/2"	119	94	64	1,62

Mortar Couplings

Material:

Malleable iron, zinc plated or nylon

For hose type:

INTONACATRICI

Construction:

System 22, not interchangeable with system 23.5

Assembly:

Safety Clamps	Worm Drive	Bolt clamps	Crimping
		X	



Part-No.	Hose I.D.	Height	Head O.D.	Weight kg/pcs
MMHS25	25	110	35	0,48
MMHS35	35	120	49,5	0,80
MMHS38	38	120	49,5	0,90
MMHS42	42	120	53	0,96
MMHS50	50	140	63	1,20
MMHS65	65	156	73	2,17



Part-No.	Thread	Height	Head O.D.	Weight kg/pcs
MMFT2535	G 1"	67	35	0,28
MMFT2550	G 1"	63	49.5	0,52
MMFT3250	G 1 1/4"	68	49.5	0,46
MMFT3850	G 1 1/2"	68	49.5	0,45
MMFT5050	G 2"	74	49.5	0,67
MMFT3853	G 1 1/2"	62	53	0,42
MMFT3263	G 1 1/4"	64	63	0,82
MMFT3863	G 1 1/2"	64	63	0,68
MMFT5063	G 2"	71	63	0,62
MMFT6563	G 2 1/2"	78	63	0,96
MMFT6573	G 2 1/2"	78	73	1,00



Part-No.	Thread	Height	Head O.D.	Weight kg/pcs
MMMT2535	G 1"	76	35	0,36
MMMT3250	G 1 1/4"	83	49.5	0,53
MMMT3853	G 1 1/2"	77	53	0,53
MMMT5063	G 2"	90	63	0,95

k



aerospace
climate control
electromechanical
filtration
fluid & gas handling
hydraulics
pneumatics
process control
sealing & shielding

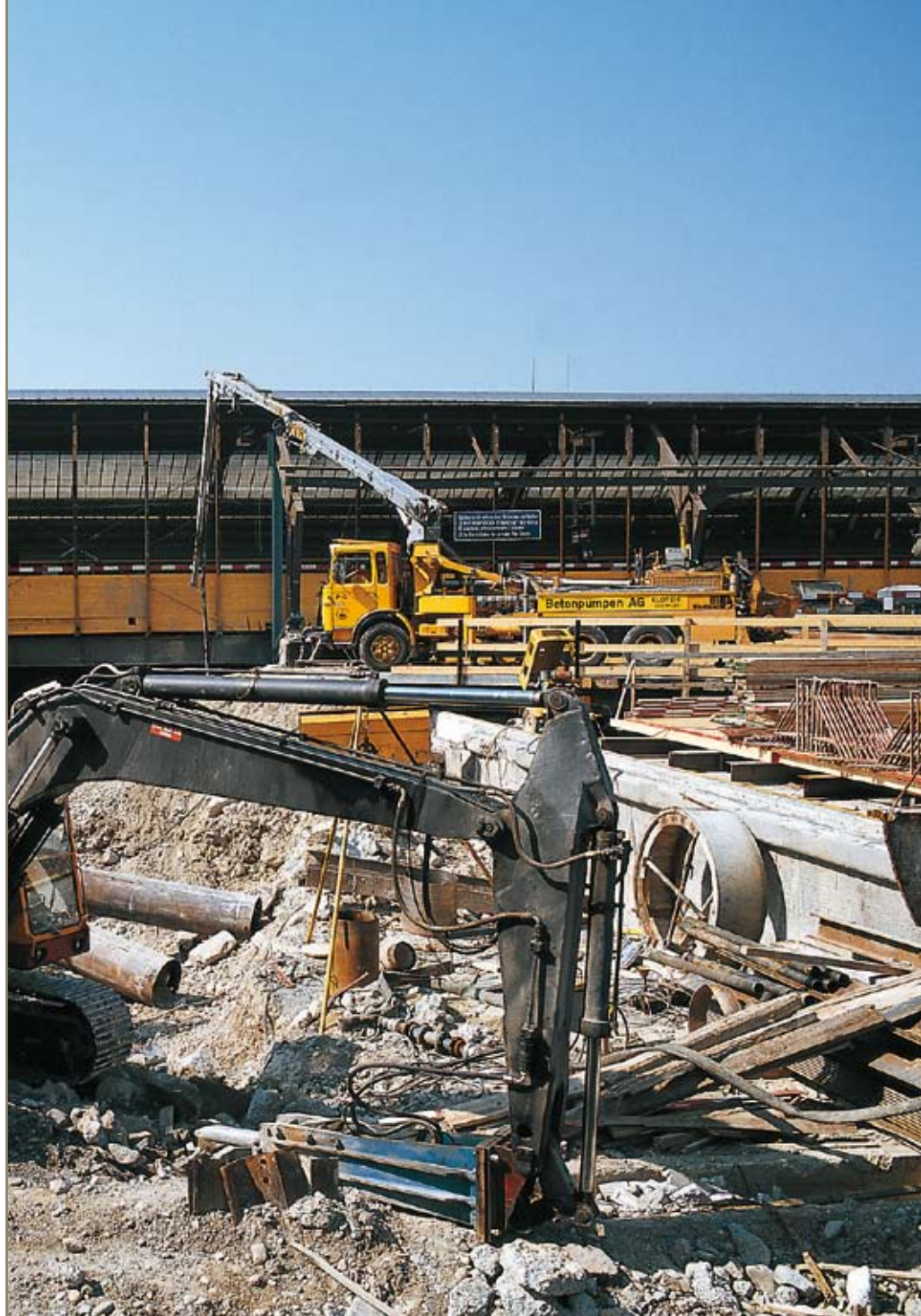

Cardan Couplings



ENGINEERING YOUR SUCCESS.

I – Cardan Couplings

Working pressure

ND	bar	psi
50	20	300
70	20	300
89	15	217
108	15	217
133	10	150
159	10	150

Working temperature

-40 °C (-40 °F) up to +80 °C (+176 °F)

Hose, coupling, assembly method and seal must be chosen in relation with the desired application and temperature range.

Material

– Galvanized carbon steel

Features

- Heavy duty quick couplings used in agricultural, irrigation, cleaning and construction applications. They are most commonly used with systems carrying water, liquid fertilizer, bulk products, etc.
- Machined extra-thick wall on hose shank, for long service life
- The seal between the male and female part, allows a deflection of +/- 15°
- Cardan couplings are not interchangeable with “BAUER” couplings

Dimensions

ND	A mm	B mm	C mm	D mm	E mm	F mm
50	230	128	85	76	51	2,6
70	270	163	108	103	63	3,6
89	310	194	136	133	76,1	2,9
108	360	232	161	154	101,6	3,6
133	370	264	188	179	127	4,0
159	370	313	223	210	152,4	4,0

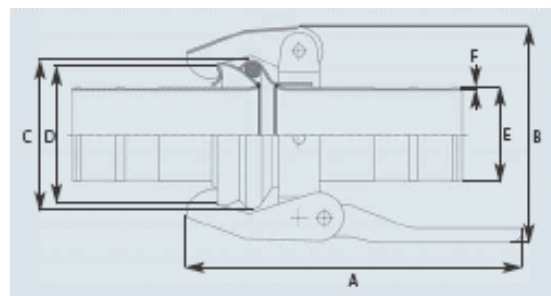

Cardan Couplings

Material: **Steel**
 For hose type: **CEMENT, IDRO, WATER, FUCINO, BEVERA**

Assembly:

Safety Clamps	Worm Drive	Bolt clamps	Crimping
		X	

Female



Steel (AISI 304 - 1.4301)

Part-No.	Hose I.D. mm	Weight kg/pcs
KMS050	50	1,13
KMS063	63	1,89
KMS075	75	3,19
KMS100	100	5,06
KMS125	125	8,01
KMS150	150	9,11

Male Seal included



Steel (AISI 304 - 1.4301)

Part-No.	Hose I.D. mm	Weight kg/pcs
KVS050	50	0,48
KVS063	63	0,88
KVS075	75	1,62
KVS100	100	2,19
KVS125	125	3,62
KVS150	150	4,30

O-RING SEAL



SBR (Styrene Butadiene Rubber)

Part-No.	O.D. Ø mm	I.D. Ø mm	Height mm	Weight kg/pcs
KX050	86,0	64,0	11,0	0,03
KX063	110,0	87,0	11,5	0,04
KX075	140,0	112,0	14,0	0,08
KX100	160,0	124,0	18,0	0,15
KX125	190,0	146,0	22,0	0,27
KX150	220,0	180,0	20,0	0,26



aerospace
climate control
electromechanical
filtration
fluid & gas handling
hydraulics
pneumatics
process control
sealing & shielding



Food DIN / SMS Couplings



ENGINEERING YOUR SUCCESS.

m – Food Couplings DIN / SMS

Food couplings complying with DIN 11851 and SMS 1148 are not interchangeable

	DIN 11851	SMS 1145
Female coupling	Conical face	Flat face
Male coupling	Deep seal	Turned-up seal
Seal	U-shape seal	Square seal
Male and female thread	Rounded thread complying with DIN 405/1	Rounded thread complying with DIN 405/1
Working pressure	≤DN38 = 40 bar (580 psi) >DN38 = 25 bar (362 psi)	6 bar / 87 psi

Working temperature

DIN 118514: -30 °C (-22 °F) up to +120 °C (+248 °F)

SMS 1145: -40 °C (-40 °F) up to +145 °C (+293 °F)

Hose, coupling, assembly method and seal must be chosen in relation with the desired application and temperature range.

Material

- Stainless steel AISI 316 - 1.4401 = hose coupling
- Stainless steel AISI 304 - 1.4301 = nut

Features

- Manufactured in compliance with the relevant norm, used in the food, chemical and pharmaceutical industry
- Both food couplings are connected the same way with a swivel nut, rounded thread DIN 405/1

Threads

Food coupling DIN 11851

DN	Thread DIN 405/1
13	RD 34 x 1/8"
19	RD 44 x 1/6"
25	RD 52 x 1/6"
32	RD 58 x 1/6"
38	RD 65 x 1/6"
50	RD 78 x 1/6"
63	RD 95 x 1/6"
75	RD 104 x 1/6"
100	RD 130 x 1/4"

Food coupling SMS 1145

DN	Thread DIN 405/1
25	RD 40 x 1/6"
32	RD 48 x 1/6"
38	RD 60 x 1/6"
50	RD 70 x 1/6"
63,5	RD 85 x 1/6"
76	RD 98 x 1/6"
100	RD 132 x 1/6"

m

Food Couplings DIN 11851

Standard: Hose shank: EN 14420-2 / DIN 2817
 Material: **Stainless Steel**
 For hose type: **DRINKPRESS, ENOTRIA, FALERNO, GAMBRINUS, MILK**
 Assembly:

Safety Clamps	Worm Drive	Bolt clamps	Crimping
X			

Female

Stainless Steel (AISI 316/1.4401)



Part-No.	Hose I.D. mm	Inch	Thread nut	Weight kg/pcs
DKV013	13	1/2	RD 34 x 1/8"	0,22
DKV019	19	3/4	RD 44 x 1/6"	0,28
DKV025	25	1	RD 52 x 1/6"	0,37
DKV032	32	1 1/4	RD 58 x 1/6"	0,44
DKV038	38	1 1/2	RD 65 x 1/6"	0,55
DKV050	50	2	RD 78 x 1/6"	0,76
DKV063	63	2 1/2	RD 95 x 1/6"	1,40
DKV075	75	3	RD 110 x 1/4"	1,89
DKV100	100	4	RD 130 x 1/4"	2,89

Male

Stainless Steel (AISI 316/1.4401)



Part-No.	Hose I.D. mm	Inch	Thread nut	Weight kg/pcs
DKM013	13	1/2	RD 34 x 1/8"	0,10
DKM019	19	3/4	RD 44 x 1/6"	0,14
DKM025	25	1	RD 52 x 1/6"	0,24
DKM032	32	1 1/4	RD 58 x 1/6"	0,32
DKM038	38	1 1/2	RD 65 x 1/6"	0,38
DKM050	50	2	RD 78 x 1/6"	0,41
DKM063	63	2 1/2	RD 95 x 1/6"	0,89
DKM075	75	3	RD 110 x 1/4"	1,35
DKM100	100	4	RD 130 x 1/4"	1,84

Food SMS Couplings

Standard: Hose shank: **EN 14420-2 / DIN 2817**
 Material: **Stainless Steel**
 For hose type: **DRINKPRESS, ENOTRIA, FALERNO, GAMBRINUS, MILK**
 Assembly:

Safety Clamps	Worm Drive	Bolt clamps	Crimping
X			

Female



Stainless Steel (AISI 316/1.4401)

Part-No.	Hose I.D. mm	Inch	Thread nut	Weight kg/pcs
SMSV025D	25	1	RD 40 x 1/6"	0,23
SMSV032D	32	1 1/4	RD 48 x 1/6"	0,32
SMSV038D	32	1 1/4	RD 60 x 1/6"	0,51
SMSV050D	50	2	RD 70 x 1/6"	0,7
SMSV063D	63	2 1/2	RD 85 x 1/6"	1,04
SMSV075D	75	3	RD 98 x 1/6"	1,61
SMSV100D	100	4	RD 132 x 1/6"	3,32

Male



Stainless Steel (AISI 316/1.4401)

Part-No.	Hose I.D. mm	Inch	Thread nut	Weight kg/pcs
SMSM025D	25	1	RD 40 x 1/6"	0,18
SMSM032D	32	1 1/4	RD 48 x 1/6"	0,25
SMSM038D	32	1 1/4	RD 60 x 1/6"	0,44
SMSM050D	50	2	RD 70 x 1/6"	0,54
SMSM063D	63	2 1/2	RD 85 x 1/6"	0,96
SMSM075D	75	3	RD 98 x 1/6"	1,25
SMSM100D	100	4	RD 132 x 1/6"	1,6





aerospace
climate control
electromechanical
filtration
fluid & gas handling
hydraulics
pneumatics
process control
sealing & shielding



Safety Clamps



ENGINEERING YOUR SUCCESS.

Safety clamps EN 14420-3/DIN 2817

Pressure range

Working pressure -0,8 bar (-12 psi) up to 25 bar (362 psi)

Temperature range

20 °C (-4 °F) to + 65 °C (149 °F)

Hose, coupling and assembly method must be chosen in relation with the desired application and temperature range.

Materials

Forged aluminium

USA	ASTM B247, grade 6061-T6
Germany	DIN 1749 grade AlMgSi1
UK	BS 1472 HE 20 Grade 6061

Forged brass

USA	ASTM B16, grade C36000
Germany	DIN 17660 grade CuZn36Pb3
UK	BS 2847 grade CZ124

Investment cast stainless steel

USA	ASTM A666 grade 316 stainless steel
Germany	DIN 17440 grade 1.4401 X5CrNiMo1810
UK	BS 316 S16

Features

- Assembly of the rubber hoses used in food, pharmaceutical and transport industry applications
- Safety clamps are used to assemble EN/DIN standardized hoses and couplings with a smooth hose shank complying with EN 14420-2 / DIN 2817
- RK safety clamps are supplied complete with nuts and bolts

Nuts and bolts

Aluminium RK safety clamps

- Bolts complying with EN ISO 4762 / DIN 912, zinc plated 8.8
- Nuts complying with EN ISO 4032 / DIN 934, zinc plated 8

Brass RK safety clamps

- Bolts complying with EN ISO 4762 / DIN 912, zinc plated 8.8
- Nuts complying with EN ISO 4032 / DIN 934, zinc plated 8

Stainless steel RK safety clamps

- Bolts complying with EN ISO 4762 / DIN 912, stainless steel A.2
- Nuts complying with EN ISO 4032 / DIN 934, stainless steel A.2

n – Safety Clamps

Safety clamps EN 14423 / DIN 2826

Pressure range

Working pressure	18 bar (261) psi with a temperature of 210 °C / 410 °F
Test pressure	90 bar (1305 psi)
Burst pressure	180 bar (2611 psi)

Temperature range

Saturated steam	+210 °C / 410 °F
Hot water	+120 °C / 248 °F

Hose, coupling and assembly method must be chosen in relation with the desired application and temperature range.

Materials

Forged brass

USA	ASTM B16, grade C36000
Germany	DIN 17660 grade CuZn36Pb3
UK	BS 2847 grade CZ124

Investment cast stainless steel

USA	ASTM A666 grade 316 stainless steel
Germany	DIN 17440 grade 1.4401 X5CrNiMo1810
UK	BS 316 S16

Features

- Steam clamps are used in saturated steam and hot water applications. EN ISO 6134 forbids the use of quick release couplings in steam applications
- Steam clamps are physically larger, longer, have deeper inner groove and consist of a thicker wall, than other safety clamps
- Steam safety clamps are not interchangeable or replaceable by any other safety clamps
- Steam safety clamps are supplied complete with nuts and bolts

Nuts and bolts

Brass steam safety clamps

- Bolts complying with EN ISO 4762 / DIN 912, zinc plated 8.8
- Nuts complying with EN ISO 4032 / DIN 934, zinc plated 8

Stainless steel steam safety clamps

- Bolts complying with EN ISO 4762 / DIN 912, stainless steel A.2
- Nuts complying with EN ISO 4032 / DIN 934, stainless steel A.2

Safety Warning

Steam applications can be hazardous; therefore assembling should only be carried out by trained personnel. Use only couplings with steam safety clamps (EN 14423 / DIN 2826). Check coupling tightness before every utilisation. Drain hose after use. When not in use, store the hose on a flat surface (shelve) and never hang from a hook. Steam hoses gradually decrease in their performances during service life. Consequently, they need to be regularly inspected by trained personnel wearing adequate protective cloths overall, including eye protection.

Safety Clamps DIN 2817

Production method: **forging**

Aluminium and Brass

Bolts: **DIN 912 / EN ISO 4762, zinc plated 8.8**

Nuts: **DIN 934 / EN ISO 4032, zinc plated 8**

Stainless Steel

Bolts: **DIN 912 / EN ISO 4762, stainless steel A.2**

Nuts: **DIN 934 / EN ISO 4032, stainless steel A.2**

Set of RK safety clamps = one pair of clamps, nuts and bolts included

Aluminium



Part-No.	Hose I.D. mm	Hose O.D. mm	Dimension		Nuts and bolts		Weight kg/pcs
			Height mm	Width mm	Quantity	Thread metric	
RK013	13 x 5	22 - 24	50	51	4	M6	0,12
RK019	19 x 6	30 - 33	50	63	4	M6	0,12
RK025	25 x 6	36 - 39	50	69	4	M6	0,14
RK032	32 x 6	43 - 46	50	76	4	M6	0,15
RK038	38 x 6,5	53 - 52	50	83	4	M6	0,15
RK050	50 x 8	63 - 67	56	102	4	M8	0,29
RK050010*	50 x 10	69 - 71	56	102	4	M8	0,33
RK063	63 x 8	78 - 82	74	120	4	M8	0,43
RK075	75 x 8	89 - 93	76	132	4	M8	0,49
RK075010*	75 x 10	94 - 97	76	132	4	M8	0,52
RK100	100 x 8	114 - 119	120	166	4	M10	1,09
RK125	125 x 10	143 - 148	145	210	6	M10	1,88
RK150	150 x 10	167 - 173	180	227	6	M12	3,78
RK200	200 x 12	222 - 229	240	284	8	M12	6,52

Brass



Part-No.	Hose I.D. mm	Hose O.D. mm	Dimension		Nuts and bolts		Weight kg/pcs
			Height mm	Width mm	Quantity	Thread metric	
RKM013	13 x 5	22 - 24	50	51	4	M6	0,29
RKM019	19 x 6	30 - 33	50	63	4	M6	0,34
RKM025	25 x 6	36 - 39	50	69	4	M6	0,39
RKM032	32 x 6	43 - 46	50	76	4	M6	0,40
RKM038	38 x 6,5	50 - 53	50	83	4	M6	0,50
RKM050	50 x 8	63 - 67	56	102	4	M8	0,90
RKM063	63 x 8	78 - 82	74	120	4	M8	1,21
RKM063010*	63 x 10	84 - 87	74	120	4	M8	1,31
RKM075	75 x 8	89 - 93	76	132	4	M8	1,39
RKM075010*	75 x 10	94 - 97	76	132	4	M8	1,52
RKM100	100 x 8	114 - 119	120	166	4	M10	1,09

Stainless Steel (AISI 316/1.4401)



Part-No.	Hose I.D. mm	Hose O.D. mm	Dimension		Nuts and bolts		Weight kg/pcs
			Height mm	Width mm	Quantity	Thread metric	
RKR013	13 x 5	22 - 24	50	51	4	M6	0,25
RKR019	19 x 6	30 - 33	50	63	4	M6	0,30
RKR025	25 x 6	36 - 39	50	69	4	M6	0,33
RKR032	32 x 6	43 - 46	50	76	4	M6	0,37
RKR038	38 x 6,5	50 - 53	50	83	4	M6	0,41
RKR050	50 x 8	63 - 67	56	102	4	M8	0,69
RKR06306	63 x 6	73 - 77					
RKR063	63 x 8	78 - 82	74	120	4	M8	1,06
RKR075	75 x 8	89 - 93	76	132	4	M8	1,20
RKR100	100 x 8	114 - 119	120	166	4	M10	2,90

Steam Clamps DIN 2826

Production method: **forging**

Aluminium and Brass

Bolts: **DIN 912 / EN ISO 4762, zinc plated 8.8**

Nuts: **DIN 934 / EN ISO 4032, zinc plated 8**

Stainless Steel

Bolts: **DIN 912 / EN ISO 4762, stainless steel A.2**

Nuts: **DIN 934 / EN ISO 4032, stainless steel A.2**

Set of RK safety clamps = one pair of clamps, nuts and bolts included

Stainless Steel (AISI 316/1.4401)



Part-No.	Hose I.D. mm	Hose O.D. mm	Dimension		Nuts and bolts		Weight kg/pcs
			Height mm	Width mm	Quantity	Thread metric	
RKSR013	13 x 6	24 - 26	65	53	4	M6	0,31
RKSR019	19 x 7	32 - 34	65	68	4	M8	0,46
RKSR025	25 x 7,5	39 - 41	65	77	4	M8	0,53
RKSR032	32 x 8	47 - 50	75	86	4	M8	0,78
RKSR038	38 x 8	53 - 56	90	101	4	M10	1,10
RKSR050	50 x 9	67 - 69	100	111	4	M10	1,29

Brass



Part-No.	Hose I.D. mm	Hose O.D. mm	Dimension		Nuts and bolts		Weight kg/pcs
			Height mm	Width mm	Quantity	Thread metric	
RKS013	13 x 6	24 - 26	65	53	4	M6	0,33
RKS019	19 x 7	32 - 34	65	68	4	M8	0,50
RKS025	25 x 7,5	39 - 41	65	77	4	M8	0,58
RKS032	32 x 8	47 - 50	75	86	4	M8	0,72
RKS038	38 x 8	53 - 56	90	101	4	M10	1,30
RKS050	50 x 9	67 - 69	100	111	4	M10	1,58



aerospace
climate control
electromechanical
filtration
fluid & gas handling
hydraulics
pneumatics
process control
sealing & shielding



Bolt Clamps



ENGINEERING YOUR SUCCESS.

o – Bolt Clamps

Material

	Steel (MIRA)	Stainless Steel (MIRAR)
Clamp	W1, galvanised steel band	W4, stainless steel AISI 304 - 1.4301
Bushing	Zinc-plated Q235LL	W4, Stainless steel AISI 304 - 1.4301
Screw	8.8	Stainless steel A2 - galvanized
Bridge	W1, galvanised steel plate	Stainless steel AISI 304 -1.4301
Working pressure	≤DN38 = 40 bar (580 psi) >DN38 = 25 bar (362 psi)	6 bar / 87 psi

Features

- Sealing and retaining suction and pressure hoses with steel or plastic reinforcement and high shore hardness.
- Bolt clamps are designed in compliance with DIN 3017, and are used to assemble various kinds of industrial hoses.
- In case of smaller hose dimensions a single band clamp is used, for larger hose diameters the use of two bold clamps is recommended.
- To prevent leakage, always place clamps in a quarter turn opposed to each other.

Threads

Bolt: Metric

Torque moment – Nm for steel band clamps

Hose O.D. min - max	Max. torque [Nm] steel clamp	Max. torque [Nm] stainless steel clamp
17 - 19	4.5	25.0
20 - 22	4.5	25.0
23 - 25	4.5	25.0
26 - 28	4.5	25.0
29 - 31	8.0	25.0
32 - 35	8.0	25.0
36 - 39	8.0	25.0
40 - 43	8.0	50.0
44 - 47	8.0	50.0
48 - 51	8.0	50.0
52 - 55	8.0	50.0
56 - 59	8.0	50.0
60 - 63	25.0	50.0
64 - 67	25.0	50.0
68 - 73	25.0	50.0
74 - 79	25.0	50.0
80 - 85	25.0	50.0

Hose O.D. min - max	Max. torque [Nm] steel clamp	Max. torque [Nm] stainless steel clamp
86 - 91	25.0	50.0
92 - 97	25.0	50.0
98 - 103	25.0	50.0
104 - 112	25.0	50.0
113 - 121	25.0	50.0
122 - 130	25.0	50.0
131 - 139	50.0	50.0
140 - 148	50.0	50.0
149 - 162	50.0	50.0
163 - 174	50.0	50.0
174 - 187	50.0	50.0
188 - 200	50.0	50.0
210 - 213	50.0	50.0
214 - 226	50.0	50.0
227 - 239	50.0	50.0
240 - 252	50.0	50.0

Bolt Clamps



Steel

Part-No.	for Hose I.D. mm	Band width mm +/- 1	Band thickness mm	Screw mm	Torque moment Nm
MIRA017	17 - 19	18,0	0,6	M5	4,5
MIRA020	20 - 22	18,0	0,6	M5	4,5
MIRA023	23 - 25	18,0	0,6	M5	4,5
MIRA026	26 - 28	18,0	0,6	M5	4,5
MIRA029	29 - 31	20,0	0,6	M6	8,0
MIRA032	32 - 35	20,0	0,8	M6	8,0
MIRA036	36 - 39	20,0	0,8	M6	8,0
MIRA040	40 - 43	20,0	0,8	M6	8,0
MIRA044	44 - 47	22,0	1,2	M6	8,0
MIRA048	48 - 51	22,0	1,2	M6	8,0
MIRA052	52 - 55	22,0	1,2	M6	8,0
MIRA056	56 - 59	22,0	1,2	M6	8,0
MIRA060	60 - 63	22,0	1,2	M8	25,0
MIRA064	64 - 67	22,0	1,2	M8	25,0
MIRA068	68 - 73	24,0	1,5	M8	25,0
MIRA074	74 - 79	24,0	1,5	M8	25,0
MIRA080	80 - 85	24,0	1,5	M8	25,0
MIRA086	86 - 91	24,0	1,5	M8	25,0
MIRA092	92 - 97	24,0	1,5	M8	25,0
MIRA098	98 - 103	24,0	1,5	M8	25,0
MIRA104	104 - 112	24,0	1,5	M8	25,0
MIRA113	113 - 121	24,0	1,5	M8	25,0
MIRA122	122 - 130	24,0	1,5	M8	25,0
MIRA131	131 - 139	26,0	1,7	M10	50,0
MIRA140	140 - 148	26,0	1,7	M10	50,0
MIRA149	149 - 161	26,0	1,7	M10	50,0
MIRA162	162 - 174	26,0	1,7	M10	50,0
MIRA175	174 - 187	26,0	1,7	M10	50,0
MIRA188	188 - 200	26,0	1,7	M10	50,0
MIRA201	201 - 213	26,0	1,7	M10	50,0
MIRA214	214 - 226	26,0	1,7	M10	50,0
MIRA227	227 - 239	26,0	1,7	M10	50,0
MIRA240	240 - 252	26,0	1,7	M10	50,0

Bolt Clamps

Stainless Steel (AISI 304 - 1.4301)



Part-No.	for Hose I.D. mm	Band width mm +/- 1	Band thickness mm	Screw mm	Torque moment Nm
MIRAR017	17 - 19	18,0	0,6	M5	25,0
MIRAR020	20 - 22	18,0	0,6	M5	25,0
MIRAR023	23 - 25	18,0	0,6	M5	25,0
MIRAR026	26 - 28	18,0	0,6	M5	25,0
MIRAR029	29 - 31	20,0	0,6	M6	25,0
MIRAR032	32 - 35	20,0	0,6	M6	25,0
MIRAR036	36 - 39	20,0	0,6	M6	25,0
MIRAR040	40 - 43	20,0	0,6	M6	50,0
MIRAR044	44 - 47	22,0	0,8	M6	50,0
MIRAR048	48 - 51	22,0	0,8	M6	50,0
MIRAR052	52 - 55	22,0	0,8	M6	50,0
MIRAR056	56 - 59	22,0	0,8	M6	50,0
MIRAR060	60 - 63	22,0	0,8	M8	50,0
MIRAR064	64 - 67	22,0	0,8	M8	50,0
MIRAR068	68 - 73	24,0	0,8	M8	50,0
MIRAR074	74 - 79	24,0	0,8	M8	50,0
MIRAR080	80 - 85	24,0	0,8	M8	50,0
MIRAR086	86 - 91	24,0	0,8	M8	50,0
MIRAR092	92 - 97	24,0	0,8	M8	50,0
MIRAR098	98 - 103	24,0	0,8	M8	50,0
MIRAR104	104 - 112	24,0	0,8	M8	50,0
MIRAR113	113 - 121	24,0	0,8	M8	50,0
MIRAR122	122 - 130	24,0	0,8	M8	50,0
MIRAR131	131 - 139	26,0	1,0	M10	50,0
MIRAR140	140 - 148	26,0	1,0	M10	50,0
MIRAR149	149 - 161	26,0	1,0	M10	50,0
MIRAR162	162 - 174	26,0	1,0	M10	50,0
MIRAR175	175 - 187	26,0	1,0	M10	50,0
MIRAR188	188 - 200	26,0	1,0	M10	50,0
MIRAR201	201 - 213	26,0	1,0	M10	50,0
MIRAR214	214 - 226	26,0	1,0	M10	50,0
MIRAR227	227 - 239	26,0	1,0	M10	50,0
MIRAR240	240 - 252	26,0	1,0	M10	50,0



aerospace
climate control
electromechanical
filtration
fluid & gas handling
hydraulics
pneumatics
process control
sealing & shielding



Worm Clamps



ENGINEERING YOUR SUCCESS.

p – Worm Clamps

Material

	Steel (MAX)	Stainless Steel (MAXR)
Clamp	W1, galvanised steel band	W4, stainless steel AISI 304 - 1.4301
Housing	Zinc-plated Q235LL	W4, Stainless steel AISI 304 - 1.4301
Screw	8.8, galvanized	Stainless steel A2

Features

- Sealing and retaining suction and pressure hose in light and medium applications.
- Worm clamps are designed to assemble various kinds of industrial hoses.
- In case of smaller hose dimensions a single worm clamp is used, for larger hose diameters the use of two worm clamps is recommended.
- To prevent leakage, always place clamps in a quarter turn opposed to each other.

Threads

Bolt: Metric

Torque moment – Nm for worm clamps

Hose O.D. min - max	Max. torque [Nm] steel clamp	Max. torque [Nm] stainless steel clamp
8 - 14	3	3
11 - 17	3	3
13 - 20	3	3
15 - 25	5	5
19 - 29	5	5
22 - 32	5	5
26 - 38	5	5
32 - 44	5	5
38 - 50	5	5
44 - 56	5	5
50 - 65	5	5
58 - 75	5	5
68 - 85	5	5
77 - 95	5	5
87 - 112	5	5
104 - 138	5	5
130 - 165	5	5
155 - 180	5	5
175 - 205	5	5
200 - 231	5	
226 - 256	5	
251 - 282	5	
277 - 307	5	
302 - 325	5	

Standard: **DIN 3017**
 Material: **Steel W1/Stainless Steel W4**
 For hose type: **All low pressure and suction rubber hoses.**



Part-No.	Stretch area mm	Band width mm	Band thickness mm	Screw mm	Torque moment	Weight gr/pcs
MAX008	8-14	9	0,5 till 1	C7 hexagonal	3	0,012
MAX011	11-17	9	0,5 till 1	C7 hexagonal	3	0,012
MAX013	13-20	9	0,5 till 1	C7 hexagonal	3	0,014
MAX015	15-25	12	0,5 till 1	C7 hexagonal	5	0,014
MAX019	19-29	12	0,5 till 1	C7 hexagonal	5	0,014
MAX022	22-32	12	0,5 till 1	C7 hexagonal	5	0,014
MAX026	26-38	12	0,5 till 1	C7 hexagonal	5	0,0145
MAX032	32-44	12	0,5 till 1	C7 hexagonal	5	0,015
MAX038	38-50	12	0,5 till 1	C7 hexagonal	5	0,016
MAX044	44-56	12	0,5 till 1	C7 hexagonal	5	0,02
MAX050	50-65	12	0,5 till 1	C7 hexagonal	5	0,04
MAX058	58-75	12	0,5 till 1	C7 hexagonal	5	0,05
MAX068	68-85	12	0,5 till 1	C7 hexagonal	5	0,05
MAX077	77-95	12	0,5 till 1	C7 hexagonal	5	0,05
MAX087	87-112	12	0,5 till 1	C7 hexagonal	5	0,06
MAX104	104-138	12	0,5 till 1	C7 hexagonal	5	0,06
MAX130	130-165	12	0,5 till 1	C7 hexagonal	5	0,063
MAX155	155-180	12	0,5 till 1	C7 hexagonal	5	0,08
MAX175	175-205	12	0,5 till 1	C7 hexagonal	5	0,12
MAX200	200-231	12	0,5 till 1	C7 hexagonal	5	0,12
MAX226	226-256	12	0,5 till 1	C7 hexagonal	5	0,12
MAX251	251-282	12	0,5 till 1	C7 hexagonal	5	0,6
MAX277	277-307	12	0,5 till 1	C7 hexagonal	5	0,6
MAX302	302-325	12	0,5 till 1	C7 hexagonal	5	0,8

Standard: **DIN 3017**
 Material: **Steel W1/Stainless Steel W4**
 For hose type: **Low pressure or suction rubber hoses, light duty and PVC/PU ducting hoses.**



Part-No.	Stretch area mm	Band width mm	Band thickness mm	Screw mm	Torque moment	Weight gr/pcs
MAXR008	8-14	9	0,5 till 1	C7 hexagonal	3	0,012
MAXR011	11-17	9	0,5 till 1	C7 hexagonal	3	0,0125
MAXR013	13-20	9	0,5 till 1	C7 hexagonal	3	0,013
MAXR015	15-25	12	0,5 till 1	C7 hexagonal	5	0,015
MAXR019	19-29	12	0,5 till 1	C7 hexagonal	5	0,016
MAXR022	22-32	12	0,5 till 1	C7 hexagonal	5	0,016
MAXR026	26-38	12	0,5 till 1	C7 hexagonal	5	0,02
MAXR032	32-44	12	0,5 till 1	C7 hexagonal	5	0,02
MAXR038	38-50	12	0,5 till 1	C7 hexagonal	5	0,02
MAXR044	44-56	12	0,5 till 1	C7 hexagonal	5	0,03
MAXR050	50-65	12	0,5 till 1	C7 hexagonal	5	0,03
MAXR058	58-75	12	0,5 till 1	C7 hexagonal	5	0,03
MAXR068	68-85	12	0,5 till 1	C7 hexagonal	5	0,04
MAXR077	77-95	12	0,5 till 1	C7 hexagonal	5	0,04
MAXR087	87-112	12	0,5 till 1	C7 hexagonal	5	0,05
MAXR104	104-138	12	0,5 till 1	C7 hexagonal	5	0,05
MAXR130	130-165	12	0,5 till 1	C7 hexagonal	5	0,053
MAXR155	155-180	12	0,5 till 1	C7 hexagonal	5	0,08
MAXR175	175-205	12	0,5 till 1	C7 hexagonal	5	0,1



aerospace
climate control
electromechanical
filtration
fluid & gas handling
hydraulics
pneumatics
process control
sealing & shielding



Crimp Fittings



ENGINEERING YOUR SUCCESS.

q – Crimp Fittings

Working pressure

Depends on hose and connection type.

Working temperature

Depends on hose type and construction, but fittings cover all temperature ranges of our industrial hoses.

Material

– Galvanized carbon steel

Features

– Galvanized steel, chromium 6 free

Chromium-6
Free

Since 1st July 2007 the EU End-of-life Vehicle Directive (ELV) came into force.

European Community Directive 2000/53/EG of 1st July 2002

- Directive manages vehicle recycling
- Prohibition on the use of chromium-6, mercury and lead with specified exceptions and the prohibition of cadmium
- Metallic chromium and chromium-3 compounds may still be used Chromium-6 has been classified in the EU Directive 67/548

EWG as Category 2, which means that this material can under certain circumstances act as a carcinogenic. Skin contact can bring about allergic reactions. Since 2006, all Parker steel fittings have been manufactured using trivalent chromate (Chromium-6-Free) plating. This new process enhances the corrosion resistance of the fittings, and is more environmentally friendly than the previous hexavalent chromate plating. While the fitting function will not change, the fitting color will. Fittings plated with trivalent chromate will be silver in color, not gold. The new plating process is implemented worldwide at all Parker facilities.

Fitting types

- ISO 12151 – DKOS, DKOL
- ISO 8434 – DKS, DKL, BEL
- DIN 7642 – Banjo
- BS 5200 – DKR, AGR
- ISO 12151 – SFL (3000 psi)

Note

Standard fitting range for all hose types up to I.D. 25 mm (1”).

For crimp diameters, any other fitting types or hose sizes, please contact us.

10064 – No-Skive crimp socket

Part Number	Hose I.D.				B
	DN	inch	size	mm	mm
10064-4-MP	6	1/4	-4	6,3	27,7
10064-5-MP	8	5/16	-5	7,9	27,7
10064-6-MP	10	3/8	-6	9,5	26,9
10064-8-MP	12	1/2	-8	12,7	27,7
10064-10-MP	16	5/8	-10	15,9	29,2
10064-12-MP	20	3/4	-12	19,1	30,2
10064-16-MP	25	1	-16	25,4	35

CA – Female Metric 24° – Light Series with O-ring – Swivel – Straight

ISO 12151-2-SWS-L – DKOL

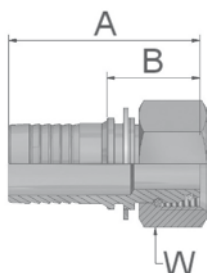

Part Number	Hose I.D.				Metric Thread	Tube mm	A mm	B mm	W mm
	DN	inch	size	mm					
KCA47-6-4*	6	1/4	-4	6,3	M12x1.5	6	49	22	14
KCA47-8-4*	6	1/4	-4	6,3	M14x1.5	8	49	22	17
KCA47-10-4*	6	1/4	-4	6,3	M16x1.5	10	49	22	19
KCA47-12-4	6	1/4	-4	6,3	M18x1.5	12	49	22	22
KCA47-8-5	8	5/16	-5	7,9	M14x1.5	8	53	26	17
KCA47-10-5*	8	5/16	-5	7,9	M16x1.5	10	49	22	19
KCA47-12-5	8	5/16	-5	7,9	M18x1.5	12	49	22	22
KCA47-8-6	10	3/8	-6	9,5	M14x1,5	8	51	26	17
KCA47-10-6*	10	3/8	-6	9,5	M16x1.5	10	48	23	19
KCA47-12-6*	10	3/8	-6	9,5	M18x1.5	12	47	23	22
KCA47-15-6*	10	3/8	-6	9,5	M22x1.5	15	49	24	27
KCA47-12-8	12	1/2	-8	12,7	M18x1.5	12	53	26	22
KCA47-15-8*	12	1/2	-8	12,7	M22x1.5	15	53	26	27
KCA47-18-8*	12	1/2	-8	12,7	M26x1.5	18	52	25	32
KCA47-15-10	16	5/8	-10	15,9	M22x1.5	15	57	29	27
KCA47-18-10*	16	5/8	-10	15,9	M26x1.5	18	53	25	32
KCA47-22-10	16	5/8	-10	15,9	M30x2	22	58	33	36
KCA47-18-12*	20	3/4	-12	19,1	M26x1.5	18	53	25	32
KCA47-22-12*	20	3/4	-12	19,1	M30x2	22	58	30	36
KCA47-28-12	20	3/4	-12	19,1	M36x2	22	63	35	41
KCA47-22-16	25	1	-16	25,4	M30x2	28	62	30	36
KCA47-28-16*	25	1	-16	25,4	M36x2	28	64	33	41
KCA47-35-16	25	1	-16	25,4	M45x2	35	65	33	50

* To order part in stainless steel material, please add suffix C to the part-number. Standard CR6F nipples are delivered with an NBR O-Ring. Add suffix V for a CR6F plated steel part with Viton O-Ring.

CE – Female Metric 24° – Light Series with O-ring – Swivel – 45° Elbow

ISO 12151-2-SWE45-L – DKOL 45°

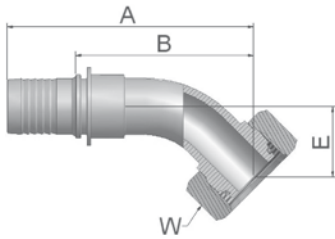

Part Number	Hose I.D.				Metric Thread	Tube mm	A mm	B mm	E mm	W mm
	DN	inch	size	mm						
KCE47-6-4	6	1/4	-4	6,3	M12x1.5	6	72	45	19	14
KCE47-8-4	6	1/4	-4	6,3	M14x1.5	8	62	35	16	17
KCE47-10-4	6	1/4	-4	6,3	M16x1.5	10	62	35	16	19
KCE47-12-4	6	1/4	-4	6,3	M18x1.5	12	62	35	16	22
KCE47-8-5	8	5/16	-5	7,9	M14x1.5	8	68	41	19	17
KCE47-10-5	8	5/16	-5	7,9	M16x1.5	10	70	43	15	19
KCE47-12-5	8	5/16	-5	7,9	M18x1.5	12	64	37	16	22
KCE47-10-6	10	3/8	-6	9,5	M16x1.5	10	70	45	20	19
KCE47-12-6*	10	3/8	-6	9,5	M18x1.5	12	70	45	19	22
KCE47-15-6	10	3/8	-6	9,5	M22x1.5	15	71	46	20	27
KCE47-12-8	12	1/2	-8	12,7	M18x1,5	12	78	51	23	22
KCE47-15-8*	12	1/2	-8	12,7	M22x1.5	15	74	47	22	27
KCE47-18-8	12	1/2	-8	12,7	M26x1,5	18	71	47	22	32
KCE47-15-10	16	5/8	-10	15,9	M22x1,5	15	82	54	26	27
KCE47-18-10	16	5/8	-10	15,9	M26x1.5	18	78	50	23	32
KCE47-22-10	16	5/8	-10	15,9	M30x2	22	84	57	24	36
KCE47-18-12	20	3/4	-12	19,1	M26x1.5	18	92	64	27	32
KCE47-22-12	20	3/4	-12	19,1	M30x2	22	91	62	26	36
KCE47-28-16*	25	1	-16	25,4	M36x2	28	115	83	33	41

* To order part in stainless steel material, please add suffix C to the part-number. Standard CR6F nipples are delivered with an NBR O-Ring. Add suffix V for a CR6F plated steel part with Viton O-Ring.

CF – Female Metric 24° – Light Series with O-ring – Swivel – 90° Elbow

ISO 12151-2-SWE-L – DKOL 90°

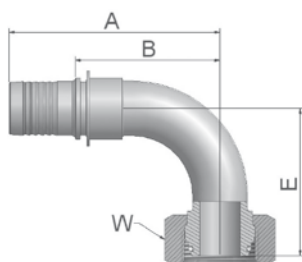

Part Number	Hose I.D.				Metric Thread	Tube mm	A mm	B mm	E mm	W mm
	DN	inch	size	mm						
KCF47-6-4*	6	1/4	-4	6,3	M12x1.5	6	60	33	33	14
KCF47-8-4*	6	1/4	-4	6,3	M14x1.5	8	55	28	29	17
KCF47-10-4	6	1/4	-4	6,3	M16x1.5	10	55	28	29	19
KCF47-12-4	6	1/4	-4	6,3	M18x1,5	12	53	26	29	22
KCF47-8-5	8	5/16	-5	7,9	M14x1,5	8	63	39	34	17
KCF47-10-5*	8	5/16	-5	7,9	M16x1.5	10	64	37	29	19
KCF47-10-5-SL60	8	5/16	-5	7,9	M16x1.5	10	60	37	60	19
KCF47-12-5	8	5/16	-5	7,9	M18x1.5	12	64	37	30	22
KCF47-10-6*	10	3/8	-6	9,5	M16x1.5	10	62	37	37	19
KCF47-12-6*	10	3/8	-6	9,5	M18x1.5	12	60	35	36	22
KCF47-12-6-SL60	10	3/8	-6	9,5	M18x1.5	12	60	35	60	22
KCF47-15-6*	10	3/8	-6	9,5	M22x1.5	15	60	35	36	27
KCF47-12-8	12	1/2	-8	12,7	M18x1,5	12	66	39	45	22
KCF47-15-8*	12	1/2	-8	12,7	M22x1.5	15	64	37	43	27
KCF47-15-8-SL70	12	1/2	-8	12,7	M22x1,5	15	64	37	70	27
KCF47-18-8	12	1/2	-8	12,7	M26x1.5	18	68	41	43	32
KCF47-15-10	16	5/8	-10	15,9	M22x1,5	15	69	41	50	27
KCF47-18-10*	16	5/8	-10	15,9	M26x1.5	18	69	41	45	32
KCF47-18-10-SL65	16	5/8	-10	15,9	M26x1.5	18	69	41	65	32
KCF47-18-10-SL70	16	5/8	-10	15,9	M26x1.5	18	69	41	70	32
KCF47-18-12	20	3/4	-12	19,1	M26x1.5	18	83	54	56	32
KCF47-22-12*	20	3/4	-12	19,1	M30x2	22	82	54	55	36
KCF47-22-12-SL60	20	3/4	-12	19,1	M30x2	22	82	54	60	36
KCF47-22-12-SL108	20	3/4	-12	19,1	M30x2	22	82	54	108	36
KCF47-22-12-SL120	20	3/4	-12	19,1	M30x2	22	82	54	120	36
KCF47-28-12	20	3/4	-12	19,1	M36x2	28	78	49	57	41
KCF47-22-16	25	1	-16	25,4	M30x2	22	104	72	74	36
KCF47-28-16*	25	1	-16	25,4	M36x2	28	103	72	71	41

* To order part in stainless steel material, please add suffix C to the part-number. Standard CR6F nipples are delivered with an NBR O-Ring. Add suffix V for a CR6F plated steel part with Viton O-Ring.

DO – Male Metric 24° – Light Series – Rigid – Straight

ISO 12151-2-S-L – CEL

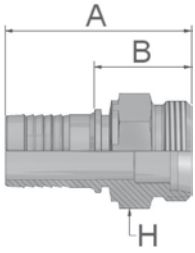

Part Number	Hose I.D.				Metric Thread	Tube mm	A mm	B mm	H mm
	DN	inch	size	mm					
KD047-6-4*	6	1/4	-4	6,3	M12x1.5	6	47	20	12
KD047-8-4	6	1/4	-4	6,3	M14x1.5	8	49	22	14
KD047-10-4	6	1/4	-4	6,3	M16x1.5	10	51	24	17
KD047-12-4	6	1/4	-4	6,3	M18x1,5	12	48	24	19
KD047-8-5	8	5/16	-5	7,9	M14x1,5	8	47	20	14
KD047-10-5*	8	5/16	-5	7,9	M16x1.5	10	51	24	17
KD047-12-5	8	5/16	-5	7,9	M18x1.5	12	51	24	19
KD047-10-6*	10	3/8	-6	9,5	M16x1.5	10	49	24	17
KD047-12-6*	10	3/8	-6	9,5	M18x1.5	12	49	24	19
KD047-15-6	10	3/8	-6	9,5	M22x1.5	15	51	26	22
KD047-12-8	12	1/2	-8	12,7	M18x1,5	12	47	23	19
KD047-15-8*	12	1/2	-8	12,7	M22x1.5	15	53	26	22
KD047-18-8	12	1/2	-8	12,7	M26x1.5	18	56	29	27
KD047-15-10	16	5/8	-10	15,9	M22x1,5	15	57	29	27
KD047-18-10	16	5/8	-10	15,9	M26x1.5	18	57	29	27
KD047-22-10	16	5/8	-10	15,9	M30x2	22	61	33	30
KD047-18-12	20	3/4	-12	19,1	M26x1.5	18	57	29	27
KD047-22-12*	20	3/4	-12	19,1	M30x2	22	62	33	30
KD047-28-16*	25	1	-16	25,4	M36x2	28	67	35	36

* To order part in stainless steel material, please add suffix C to the part-number.

CO – Female Metric – Very Light Series LL – Swivel – Straight (Ball Nose)

DKM

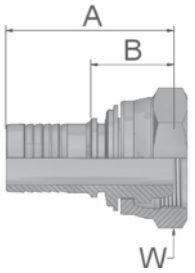

Part Number	Hose I.D.				Metric Thread	A mm	B mm	W mm
	DN	inch	size	mm				
KC047-20-12	20	3/4	-12	19,1	M30x1,5	56	28	36
KC047-25-16	25	1	-16	25,4	M38x1,5	63	32	46

C3 – Female Metric – Light Series – Swivel – Straight (Ball Nose)

DKL

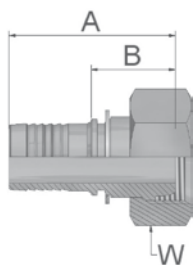

Part Number	Hose I.D.				Metric Thread	Tube mm	A mm	B mm	W mm
	DN	inch	size	mm					
KC347-6-4	6	1/4	-4	6,3	M12x1,5	6	49	22	14
KC347-8-4	6	1/4	-4	6,3	M14x1.5	8	48	21	17
KC347-10-4	6	1/4	-4	6,3	M16x1,5	10	49	22	19
KC347-10-5	8	5/16	-5	7,9	M16x1,5	10	46	22	19
KC347-12-5	8	5/16	-5	7,9	M18x1,5	12	46	22	22
KC347-10-6	10	3/8	-6	9,5	M16x1,5	10	47	24	19
KC347-12-6	10	3/8	-6	9,5	M18x1,5	12	47	22	22
KC347-15-8	12	1/2	-8	12,7	M22x1,5	15	48	24	27
KC347-18-10	16	5/8	-10	15,9	M26x1,5	18	53	26	32
KC347-22-12	20	3/4	-12	19,1	M30x2	22	58	30	36
KC347-28-16	25	1	-16	25,4	M36x2	28	64,5	32,5	41

C4 – Female Metric – Light Series – Swivel – 45° Elbow (Ball Nose)

DKL 45°

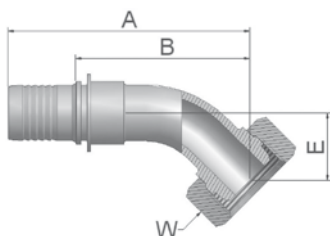

Part Number	Hose I.D.				Metric Thread	Tube mm	A mm	B mm	E mm	W mm
	DN	inch	size	mm						
KC447-8-4	6	1/4	-4	6,3	M14x1.5	8	60	33	14	17
KC447-10-5	8	5/16	-5	7,9	M16x1,5	10	61	34	15	19
KC447-10-6	10	3/8	-6	9,5	M16x1,5	10	72	47	21	19
KC447-12-6	10	3/8	-6	9,5	M18x1,5	12	69	44	18	22
KC447-15-8	12	1/2	-8	12,7	M22x1,5	15	72	45	19	27
KC447-18-10	16	5/8	-10	15,9	M26x1,5	18	74	46	19	32

C5 – Female Metric – Light Series – Swivel – 90° Elbow (Ball Nose)

DKL 90°

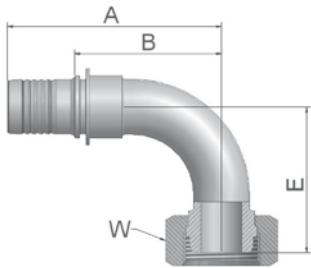

Part Number	Hose I.D.				Metric Thread	Tube mm	A mm	B mm	E mm	W mm
	DN	inch	size	mm						
KC547-6-4	6	1/4	-4	6,3	M12x1,5	6	52	25	29	14
KC547-8-4	6	1/4	-4	6,3	M14x1.5	8	48	25	26	17
KC547-10-5	8	5/16	-5	7,9	M16x1.5	10	64	37	33	19
KC547-12-5	8	5/16	-5	7,9	M18x1,5	12	53	26	28	22
KC547-10-6	10	3/8	-6	9,5	M16x1,5	10	58	35	35	19
KC547-12-6	10	3/8	-6	9,5	M18x1.5	12	60	35	34	22
KC547-15-8	12	1/2	-8	12,7	M22x1.5	15	67	41	39	27
KC547-18-10	16	5/8	-10	15,9	M26x1.5	18	69	41	43	32
KC547-22-12	20	3/4	-12	19,1	M30x2	22	82	54	50	36

1D – Metric Standpipe – Light Series – Rigid – Straight

ISO 8434-1 – BEL

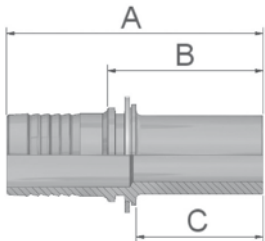
Not recommended for new applications

Part Number	Hose I.D.				Tube mm	A mm	B mm	C mm
	DN	inch	size	mm				
K1D47-6-4*	6	1/4	-4	6,3	6	57	30	22
K1D47-8-4*	6	1/4	-4	6,3	8	57	30	22
K1D47-10-4	6	1/4	-4	6,3	10	58	31	23
K1D47-12-4	6	1/4	-4	6,3	12	58	31	23
K1D47-8-5	8	5/16	-5	7,9	8	54	30	22
K1D47-10-5	8	5/16	-5	7,9	10	58	31	23
K1D47-10-6*	10	3/8	-6	9,5	10	56	31	23
K1D47-12-6*	10	3/8	-6	9,5	12	56	31	23
K1D47-15-8	12	1/2	-8	12,7	15	60	33	25
K1D47-18-8	12	1/2	-8	12,7	18	61	34	26
K1D47-18-10	16	5/8	-10	15,9	18	62	34	26
K1D47-22-12*	20	3/4	-12	19,1	22	65	36	28
K1D47-28-16	25	1	-16	25,4	28	72	40	30

DD – Metric Standpipe – Ligth Series – 45° Elbow

ISO 8434-1 – BEL45

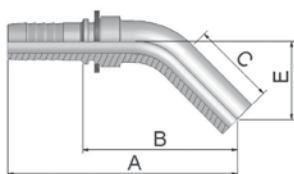
Not recommended for new applications

Part Number	Hose I.D.				Tube mm	A mm	B mm	C mm	E mm
	DN	inch	size	mm					
KDD47-6-4	6	1/4	-4	6,3	6	72	45	21	19
KDD47-8-4	6	1/4	-4	6,3	8	73	46	22	19
KDD47-10-5	8	5/16	-5	7,9	10	76	49	23	21
KDD47-12-6	10	3/8	-6	9,5	12	74	49	22	21
KDD47-15-8	12	1/2	-8	12,7	15	83	56	30	28

5D – Metric Standpipe – Ligth Series – 90° Elbow

ISO 8434-1 – BEL90

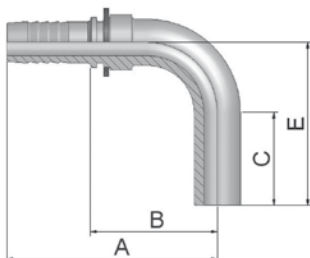
Not recommended for new applications

Part Number	Hose I.D.				Tube mm	A mm	B mm	C mm	E mm
	DN	inch	size	mm					
K5D47-6-4	6	1/4	-4	6,3	6	60	33	19	30
K5D47-8-4	6	1/4	-4	6,3	8	55	31	22	34
K5D47-10-5	8	5/16	-5	7,9	10	62	35	25	38
K5D47-12-6	10	3/8	-6	9,5	12	60	37	27	44
K5D47-15-6	10	3/8	-6	9,5	15	69	44	30	52
K5D47-15-8	12	1/2	-8	12,7	15	68	41	30	52
K5D47-18-8	12	1/2	-8	12,7	18	73	46	26	53
K5D47-22-12	20	3/4	-12	19,1	22	85	57	28	66
K5D47-28-16	25	1	-16	25,4	28	102	72	30	80

C9 – Female Metric 24° – Heavy Series with O-ring – Swivel – Straight

ISO 12151-2-SWS-S – DKOS

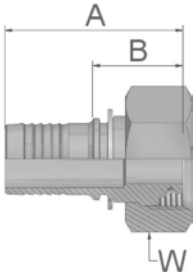

Part Number	Hose I.D.				Metric Thread	Tube mm	A mm	B mm	W mm
	DN	inch	size	mm					
KC947-6-4	6	1/4	-4	6,3	M14x1,5	6	49	26	17
KC947-8-4*	6	1/4	-4	6,3	M16x1,5	8	50	23	19
KC947-10-4*	6	1/4	-4	6,3	M18x1,5	10	49	22	22
KC947-12-4	6	1/4	-4	6,3	M20x1,5	12	47	24	24
KC947-8-5	8	5/16	-5	7,9	M16x1,5	8	49	23	19
KC947-10-5*	8	5/16	-5	7,9	M18x1,5	10	49	22	22
KC947-12-5*	8	5/16	-5	7,9	M20x1,5	12	51	24	24
KC947-14-5	8	5/16	-5	7,9	M22x1,5	14	51	24	27
KC947-10-6	10	3/8	-6	9,5	M18x1,5	10	47	23	22
KC947-12-6*	10	3/8	-6	9,5	M20x1,5	12	49	24	24
KC947-14-6*	10	3/8	-6	9,5	M22x1,5	14	49	24	27
KC947-16-6	10	3/8	-6	9,5	M24x1,5	16	52	28	30
KC947-14-8	12	1/2	-8	12,7	M22x1,5	14	51	24	27
KC947-16-8*	12	1/2	-8	12,7	M24x1,5	16	55	28	30
KC947-16-10	16	5/8	-10	15,9	M24x1,5	16	56	28	30
KC947-20-10*	16	5/8	-10	15,9	M30x2	20	55	28	36
KC947-20-12*	20	3/4	-12	19,1	M30x2	20	58	30	36
KC947-25-12*	20	3/4	-12	19,1	M36x2	25	63	35	46
KC947-25-16*	25	1	-16	25,4	M36x2	25	65	33	46
KC947-30-16*	25	1	-16	25,4	M42x2	30	70	38	50
KC947-38-16	25	1	-16	25,4	M52x2	38	70	39	60

* To order part in stainless steel material, please add suffix C to the part-number. Standard CR6F nipples are delivered with an NBR O-Ring. Add suffix V for a CR6F plated steel part with Viton O-Ring.

OC – Female Metric 24° – Heavy Series with O-ring – Swivel – 45° Elbow

ISO 12151-2-SWE45-S – DKOS 45°

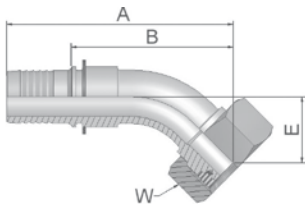

Part Number	Hose I.D.				Metric Thread	Tube mm	A mm	B mm	E mm	W mm
	DN	inch	size	mm						
K0C47-6-4	6	1/4	-4	6,3	M14x1,5	6	64	37	17	17
K0C47-8-4	6	1/4	-4	6,3	M16x1,5	8	62	35	16	19
K0C47-10-4	6	1/4	-4	6,3	M18x1,5	10	62	35	16	22
K0C47-10-5	8	5/16	-5	7,9	M18x1,5	10	65	38	17	22
K0C47-12-5	8	5/16	-5	7,9	M20x1,5	12	74	47	17	24
K0C47-12-6*	10	3/8	-6	9,5	M20x1,5	12	71	46	20	24
K0C47-14-6	10	3/8	-6	9,5	M22x1,5	14	71	46	20	27
K0C47-16-8	12	1/2	-8	12,7	M24x1,5	16	75	49	23	30
K0C47-16-10	16	5/8	-10	15,9	M24x1,5	16	80	52	24	30
K0C47-20-10	16	5/8	-10	15,9	M30x2	20	79	51	25	36
K0C47-20-12	20	3/4	-12	19,1	M30x2	20	90	60	29	36
K0C47-25-12	20	3/4	-12	19,1	M36x2	25	93	65	29	46
K0C47-30-16	25	1	-16	25,4	M42x2	30	118	86	36	50

1C – Female Metric 24° – Heavy Series with O-ring – Swivel – 90° Elbow

ISO 12151-2-SWE-S – DKOS 90°

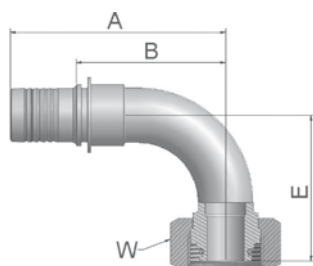

Part Number	Hose I.D.				Metric Thread	Tube mm	A mm	B mm	E mm	W mm
	DN	inch	size	mm						
K1C47-6-4	6	1/4	-4	6,3	M14x1,5	6	61	38	32	17
K1C47-8-4*	6	1/4	-4	6,3	M16x1,5	8	56	29	30	19
K1C47-10-4*	6	1/4	-4	6,3	M18x1,5	10	53	26	29	22
K1C47-12-4	6	1/4	-4	6,3	M20x1,5	12	65	38	31	24
K1C47-8-5	8	5/16	-5	7,9	M16x1,5	8	64	37	30	19
K1C47-10-5	8	5/16	-5	7,9	M18x1,5	10	63	37	31	22
K1C47-12-5	8	5/16	-5	7,9	M20x1,5	12	64	36	32	24
K1C47-10-6	10	3/8	-6	9,5	M18x1,5	10	61	36	36	22
K1C47-12-6*	10	3/8	-6	9,5	M20x1,5	12	60	35	37	24
K1C47-14-6	10	3/8	-6	9,5	M22x1,5	14	60	35	37	27
K1C47-14-8	12	1/2	-8	12,7	M22x1,5	14	65	38	42	27
K1C47-16-8*	12	1/2	-8	12,7	M24x1,5	16	64	37	45	30
K1C47-16-8-SL85	12	1/2	-8	12,7	M24x1,5	16	64	37	85	30
K1C47-16-8-SL115	12	1/2	-8	12,7	M24x1,5	16	64	37	115	30
K1C47-20-8	12	1/2	-8	12,7	M30x2	20	64	37	46	36
K1C47-16-10	16	5/8	-10	15,9	M24x1,5	16	69	41	48	30
K1C47-20-10*	16	5/8	-10	15,9	M30x2	20	68	40	48	36
K1C47-25-10	16	5/8	-10	15,9	M36x2	25	68	40	52	46
K1C47-20-12*	20	3/4	-12	19,1	M30x2	20	82	54	58	36
K1C47-25-12*	20	3/4	-12	19,1	M36x2	25	82	54	59	46
K1C47-30-12	20	3/4	-12	19,1	M42x2	30	83	54	61	50
K1C47-25-16	25	1	-16	25,4	M36x2	25	104	72	71	46
K1C47-30-16	25	1	-16	25,4	M42x2	30	107	75	75	50

* To order part in stainless steel material, please add suffix C to the part-number. Standard CR6F nipples are delivered with an NBR O-Ring. Add suffix V for a CR6F plated steel part with Viton O-Ring.

D2 – Male Metric 24° – Heavy Series – Rigid – Straight

ISO 12151-2-S-S – CES

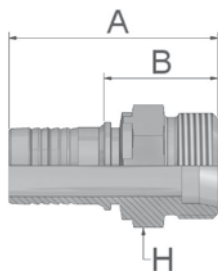

Part Number	Hose I.D.				Metric Thread	Tube mm	A mm	B mm	H mm
	DN	inch	size	mm					
KD247-6-4*	6	1/4	-4	6,3	M14x1,5	6	51	24	14
KD247-8-4*	6	1/4	-4	6,3	M16x1.5	8	51	24	17
KD247-10-4*	6	1/4	-4	6,3	M18x1.5	10	53	26	19
KD247-12-4	6	1/4	-4	6,3	M20x1,5	12	49	26	22
KD247-10-5	8	5/16	-5	7,9	M18x1,5	10	50	26	19
KD247-12-5*	8	5/16	-5	7,9	M20x1.5	12	53	26	22
KD247-14-5	8	5/16	-5	7,9	M22x1,5	14	55	28	22
KD247-10-6	10	3/8	-6	9,5	M18x1,5	10	50	27	19
KD247-12-6	10	3/8	-6	9,5	M20x1.5	12	51	26	22
KD247-14-6*	10	3/8	-6	9,5	M22x1.5	14	53	28	22
KD247-16-8*	12	1/2	-8	12,7	M24x1.5	16	56	29	24
KD247-16-10	16	5/8	-10	15,9	M24x1,5	16	58	30	24
KD247-20-10*	16	5/8	-10	15,9	M30x2	20	60	32	30
KD247-20-12*	20	3/4	-12	19,1	M30x2	20	64	35	30
KD247-25-12*	20	3/4	-12	19,1	M36x2	25	64	38	36
KD247-25-16	25	1	-16	25,4	M36x2	25	71	39	36
KD247-30-16*	25	1	-16	25,4	M42x2	30	74	42	46

* To order part in stainless steel material, please add suffix C to the part-number.

49 – Metric Banjo – Straight

DIN 7642

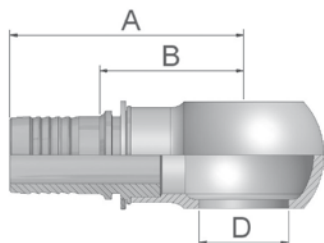

Part Number	Hose I.D.				D mm	A mm	B mm
	DN	inch	size	mm			
K4947-10-4	6	1/4	-4	6,3	10	51	24
K4947-12-4	6	1/4	-4	6,3	12	53	26
K4947-14-4	6	1/4	-4	6,3	14	55	28
K4947-17-4	6	1/4	-4	6,3	17	56	29
K4947-14-5	8	5/16	-5	7,9	14	57	28
K4947-16-5	8	5/16	-5	7,9	16	57	30
K4947-17-5	8	5/16	-5	7,9	17	57	30
K4947-14-6	10	3/8	-6	9,5	14	53	28
K4947-16-6	10	3/8	-6	9,5	16	55	30
K4947-17-6	10	3/8	-6	9,5	17	55	30
K4947-18-6	10	3/8	-6	9,5	18	57	32
K4947-18-8	12	1/2	-8	12,7	18	56	32
K4947-22-8	12	1/2	-8	12,7	22	62	35
K4947-22-10	16	5/8	-10	15,9	22	60	35
K4947-26-12	20	3/4	-12	19,1	26	66	40
K4947-27-12	20	3/4	-12	19,1	26,75	66	40
K4947-30-16	25	1	-16	25,4	30	79	47

Banjo screws and copper rings are described in our catalogue 4400.

92 – Female BSP Parallel Pipe – Swivel – Straight (60° Cone)

BS5200-A – DKR

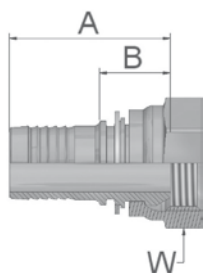

Part Number	Hose I.D.				BSP Thread	A mm	B mm	W mm
	DN	inch	size	mm				
K9247-2-4	6	1/4	-4	6,3	1/8x28	44	17	14
K9247-4-4*	6	1/4	-4	6,3	1/4x19	46	19	19
K9247-6-4	6	1/4	-4	6,3	3/8x19	47	20	22
K9247-4-5	8	5/16	-5	7,9	1/4x19	46	19	19
K9247-6-5	8	5/16	-5	7,9	3/8x19	47	20	22
K9247-4-6	10	3/8	-6	9,5	1/4x19	45	20	19
K9247-6-6*	10	3/8	-6	9,5	3/8x19	45	20	22
K9247-8-6	10	3/8	-6	9,5	1/2x14	47	22	27
K9247-6-8	12	1/2	-8	12,7	3/8x19	48	21	22
K9247-8-8*	12	1/2	-8	12,7	1/2x14	49	22	27
K9247-10-8	12	1/2	-8	12,7	5/8x14	48	21	30
K9247-12-8	12	1/2	-8	12,7	3/4x14	47	23	32
K9247-8-10	16	5/8	-10	15,9	1/2x14	50	22	27
K9247-10-10	16	5/8	-10	15,9	5/8x14	48	20	30
K9247-12-10	16	5/8	-10	15,9	3/4x14	50	22	32
K9247-12-12*	20	3/4	-12	19,1	3/4x14	51	23	32
K9247-16-12	20	3/4	-12	19,1	1x11	54	25	41
K9247-16-16*	25	1	-16	25,4	1x11	57	25	41
K9247-20-16	25	1	-16	25,4	1-1/4x11	63	31	50

B1 – Female BSP Parallel Pipe – Swivel – 45° Elbow (60° Cone)

BS 5200-D – DKR 45°

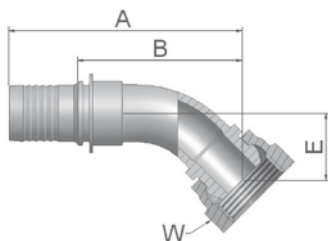

Part Number	Hose I.D.				BSP Thread	A mm	B mm	E mm	W mm
	DN	inch	size	mm					
KB147-4-4	6	1/4	-4	6,3	1/4x19	62	35	16	19
KB147-4-5	8	5/16	-5	7,9	1/4x19	67	40	19	19
KB147-6-5	8	5/16	-5	7,9	3/8x19	63	36	15	22
KB147-6-6	10	3/8	-6	9,5	3/8x19	81	58	17	22
KB147-8-6	10	3/8	-6	9,5	1/2x14	65	40	17	27
KB147-6-8	12	1/2	-8	12,7	3/8x19	75	49	21	22
KB147-8-8	12	1/2	-8	12,7	1/2x14	75	48	20	27
KB147-10-8	12	1/2	-8	12,7	5/8x14	72	45	19	30
KB147-12-8	12	1/2	-8	12,7	3/4x14	71	44	20	32
KB147-10-10	16	5/8	-10	15,9	5/8x14	80	52	22	30
KB147-12-10	16	5/8	-10	15,9	3/4x14	77	49	21	32
KB147-12-12*	20	3/4	-12	19,1	3/4x14	89	61	25	32
KB147-16-16*	25	1	-16	25,4	1x11	108	76	31	41

* suffix C: stainless steel material, suffix V: Viton O-Ring

B2 – Female BSP Parallel Pipe – Swivel – 90° Elbow (60° Cone)

BS 5200-B – DKR 90

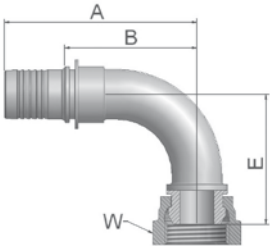

Part Number	Hose I.D.				BSP Thread	A mm	B mm	E mm	W mm
	DN	inch	size	mm					
KB247-2-4	6	1/4	-4	6,3	1/8x28	50	26	28	14
KB247-4-4*	6	1/4	-4	6,3	1/4x19	53	26	28	19
KB247-6-4	6	1/4	-4	6,3	3/8x19	54	27	27	22
KB247-4-5	8	5/16	-5	7,9	1/4x19	55	28	34	19
KB247-6-5	8	5/16	-5	7,9	3/8x19	55	28	28	22
KB247-6-6*	10	3/8	-6	9,5	3/8x19	63	38	33	22
KB247-8-6	10	3/8	-6	9,5	1/2x14	62	38	36	27
KB247-6-8	12	1/2	-8	12,7	3/8x19	63	40	41	22
KB247-8-8*	12	1/2	-8	12,7	1/2x14	67	40	41	27
KB247-10-8	12	1/2	-8	12,7	5/8x14	67	43	39	30
KB247-12-8	12	1/2	-8	12,7	3/4x14	63	36	40	32
KB247-10-10	16	5/8	-10	15,9	5/8x14	70	45	44	30
KB247-12-10	16	5/8	-10	15,9	3/4x14	73	45	42	32
KB247-12-12*	20	3/4	-12	19,1	3/4x14	82	54	53	32
KB247-16-12	20	3/4	-12	19,1	1x11	80	54	54	41
KB247-16-16*	25	1	-16	25,4	1x11	107	75	69	41

* suffix C: stainless steel material, suffix V: Viton O-Ring

EA – Female BSP Parallel Pipe - Swivel with O-Ring - Straight (60° Cone)

BS 5200 – ISO 12151-6 – DKOR

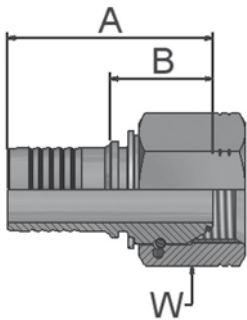

Part Number	Hose I.D.				BSP Thread	A mm	B mm	W mm
	DN	inch	size	mm				
KEA47-4-4	6	1/4	-4	6,3	1/4x19	48	21	19
KEA47-6-4	6	1/4	-4	6,3	3/8x19	53	26	22
KEA47-4-6	10	3/8	-6	9,5	1/4x19	46	21	19
KEA47-6-6	10	3/8	-6	9,5	3/8x19	50	26	22
KEA47-8-6	10	3/8	-6	9,5	1/2x14	53	28	27
KEA47-8-8	12	1/2	-8	12,7	1/2x14	55	28	27
KEA47-12-12	20	3/4	-12	19,1	3/4x14	52	24	32
KEA47-16-16	25	1	-16	25,4	1x11	63	63	41

EB – BSP Swivel Female with O-ring – 45° Elbow (60° Cone)

BS 5200 – ISO 12151-6 – DKOR 45°

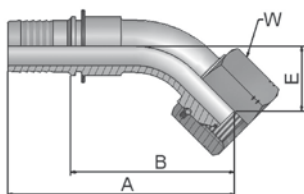

Part Number	Hose I.D.				BSP Thread	A mm	B mm	E mm	W mm
	DN	inch	size	mm					
KEB47-4-4	6	1/4	-4	6,3	1/4x19	62	35	16	19
KEB47-6-6	10	3/8	-6	9,5	3/8x19	71	46	17	22
KEB47-8-8	12	1/2	-8	12,7	1/2x14	75	48	20	27
KEB47-12-12	20	3/4	-12	19,1	3/4x14	91	63	27	32
KEB47-16-16	25	1	-16	25,4	1x11	115	83	33	41

EC – Female BSP Parallel Pipe - Swivel with O-Ring - 90° Elbow (60° Cone)

BS 5200 – ISO 12151-6 – DKOR 90°

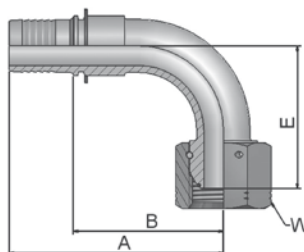

Part Number	Hose I.D.				BSP Thread	A mm	B mm	E mm	W mm
	DN	inch	size	mm					
KEC47-4-4	6	1/4	-4	6,3	1/4x19	53	26	28	19
KEC47-6-6	10	3/8	-6	9,5	3/8x19	63	38	33	22
KEC47-8-6	10	3/8	-6	9,5	1/2x14	62	38	36	27
KEC47-8-8	12	1/2	-8	12,7	1/2x14	67	40	40	27
KEC47-10-8	12	1/2	-8	12,7	5/8x14	67	40	39	30
KEC47-10-10	16	5/8	-10	15,9	5/8x14	73	45	44	30
KEC47-12-10	16	5/8	-10	15,9	3/4x14	73	45	42	32
KEC47-12-12	20	3/4	-12	19,1	3/4x14	82	54	55	32
KEC47-16-16*	25	1	-16	25,4	1x11	106	75	71	41

* To order part in stainless steel material, please add suffix C to the part-number. Standard CR6F nipples are delivered with an NBR O-Ring. Add suffix V for a CR6F plated steel part with Viton O-Ring.

D9 – Male BSP Parallel Pipe – Rigid – Straight (60° Cone)

BS5200 – AGR

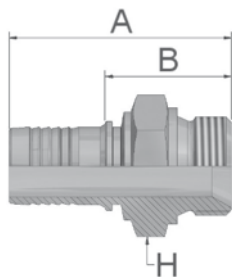

Part Number	Hose I.D.				BSP Thread	A mm	B mm	H mm
	DN	inch	size	mm				
KD947-2-4	6	1/4	-4	6,3	1/8x28	49	22	14
KD947-4-4	6	1/4	-4	6,3	1/4x19	54	27	19
KD947-6-4	6	1/4	-4	6,3	3/8x19	58	31	22
KD947-8-4	6	1/4	-4	6,3	1/2x14	60	33	27
KD947-4-5	8	5/16	-5	7,9	1/4x19	51	27	19
KD947-6-5	8	5/16	-5	7,9	3/8x19	58	31	22
KD947-4-6	10	3/8	-6	9,5	1/4x19	52	27	19
KD947-6-6*	10	3/8	-6	9,5	3/8x19	56	31	22
KD947-8-6	10	3/8	-6	9,5	1/2x14	58	33	27
KD947-6-8	12	1/2	-8	12,7	3/8x19	54	30	22
KD947-8-8*	12	1/2	-8	12,7	1/2x14	60	33	27
KD947-10-8	12	1/2	-8	12,7	5/8x14	62	35	30
KD947-12-8	12	1/2	-8	12,7	3/4x14	63	36	32
KD947-8-10	16	5/8	-10	15,9	1/2x14	61	33	27
KD947-10-10	16	5/8	-10	15,9	5/8x14	63	36	30
KD947-12-10	16	5/8	-10	15,9	3/4x14	64	37	32
KD947-12-12*	20	3/4	-12	19,1	3/4x14	65	36	32
KD947-16-12	20	3/4	-12	19,1	1x11	70	42	41
KD947-16-16*	25	1	-16	25,4	1x11	74	42	41
KD947-20-16	25	1	-16	25,4	1-1/4x11	77	46	50

* To order parts in stainless steel material please add suffix C to the part-number.

91 – Male BSP Taper Pipe – Rigid – Straight

BS5200 – AGR-K

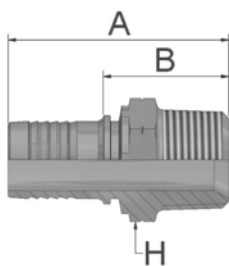

Part Number	Hose I.D.				BSP Thread	A mm	B mm	H mm
	DN	inch	size	mm				
K9147-4-4*	6	1/4	-4	6,3	1/4x19	49	26	14
K9147-6-4	6	1/4	-4	6,3	3/8x19	54	27	17
K9147-6-5	8	5/16	-5	7,9	3/8x19	54	27	19
K9147-6-6*	10	3/8	-6	9,5	3/8x19	52	28	19
K9147-8-6	10	3/8	-6	9,5	1/2x14	59	34	22
K9147-8-8	12	1/2	-8	12,7	1/2x14	57	33	22
K9147-12-10	16	5/8	-10	15,9	3/4x14	65	38	27
K9147-12-12	20	3/4	-12	19,1	3/4x14	66	37	27
K9147-16-16	25	1	-16	25,4	1x11	72	42	36

* To order parts in stainless steel material please add suffix C to the part-number.

B5 – Female BSP Parallel Pipe – Swivel – Straight (Flat Seat)

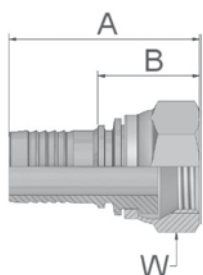

Part Number	Hose I.D.				BSP Thread	A mm	B mm	W mm
	DN	inch	size	mm				
KB547-4-4	6	1/4	-4	6,3	1/4x19	41	17	19
KB547-6-5	8	5/16	-5	7,9	3/8x19	41	14	22
KB547-6-6	10	3/8	-6	9,5	3/8x19	37	14	22
KB547-8-6	10	3/8	-6	9,5	1/2x14	45	20	27
KB547-8-8	12	1/2	-8	12,7	1/2x14	46	19	27
KB547-12-8	12	1/2	-8	12,7	3/4x14	43	19	32
KB547-12-10	16	5/8	-10	15,9	3/4x14	43	18	32
KB547-12-12	20	3/4	-12	19,1	3/4x14	44	18	32
KB547-16-16	25	1	-16	25,4	1x11	53	22	41

15 – SAE Code 61 – Flange Head – Straight

ISO 12151-3-S-L – SFL – 3000 psi

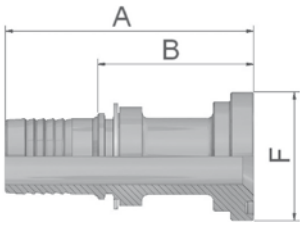

Part Number	Hose I.D.				flange size	A mm	B mm	F mm
	DN	inch	size	mm				
K1547-8-8	12	1/2	-8	12,7	1/2	77	51	30
K1547-12-8	12	1/2	-8	12,7	3/4	54	27	38
K1547-12-10	16	5/8	-10	15,9	3/4	58	31	38
K1547-12-12	20	3/4	-12	19,1	3/4	84	56	38
K1547-16-12	20	3/4	-12	19,1	1	59	30	45
K1547-16-16	25	1	-16	25,4	1	86	54	45
K1547-20-16	25	1	-16	25,4	1.1/4	106	74	51
K1547-24-16	25	1	-16	25,4	1-1/2	99	67	60

17 – SAE Code 61 – Flange Head – 45° Elbow

ISO 12151-3-E45-L – SFL 45° – 3000 psi

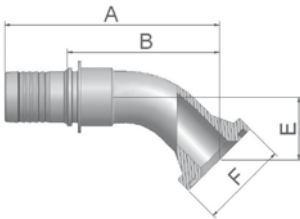

Part Number	Hose I.D.				flange size	A mm	B mm	E mm	F mm
	DN	inch	size	mm					
K1747-8-8	12	1/2	-8	12,7	1/2	75	48	20	30
K1747-12-8	12	1/2	-8	12,7	3/4	74	47	21	38
K1747-12-10	16	5/8	-10	15,9	3/4	78	50	24	38
K1747-12-12	20	3/4	-12	19,1	3/4	90	62	25	38
K1747-16-12	20	3/4	-12	19,1	1	90	61	25	45
K1747-16-16	25	1	-16	25,4	1	110	78	32	45
K1747-20-16	25	1	-16	25,4	1.1/4	106	74	27	51

19 – SAE Code 61 – Flange Head – 90° Elbow

ISO 12151-3-E-L – SFL 90° – 3000 psi

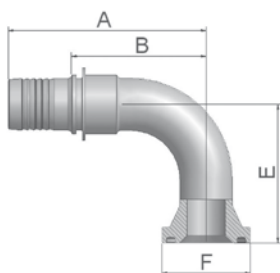

Part Number	Hose I.D.				flange size	A mm	B mm	E mm	F mm
	DN	inch	size	mm					
K1947-8-8	12	1/2	-8	12,7	1/2	67	40	41	30
K1947-12-8	12	1/2	-8	12,7	3/4	74	47	43	38
K1947-12-10	16	5/8	-10	15,9	3/4	81	53	52	38
K1947-16-10	16	5/8	-10	15,9	1	81	53	52	45
K1947-16-10-SL90	16	5/8	-10	15,9	1	81	53	90	45
K1947-12-12*	20	3/4	-12	19,1	3/4	82	54	58	38
K1947-16-12	20	3/4	-12	19,1	1	82	54	58	45
K1947-12-16	25	1	-16	25,4	3/4	100	68	70	38
K1947-16-16*	25	1	-16	25,4	1	100	68	70	45
K1947-20-16	25	1	-16	25,4	1.1/4	105	73	60	51
K1947-24-16	25	1	-16	25,4	1-1/2	92	62	62	60

* suffix C: stainless steel material, suffix V: Viton O-Ring

Parker's Motion & Control Technologies

At Parker, we're guided by a relentless drive to help our customers become more productive and achieve higher levels of profitability by engineering the best systems for their requirements. It means looking at customer applications from many angles to find new ways to create value. Whatever the motion and control technology need, Parker has the experience, breadth of product and global reach to consistently deliver. No company knows more about motion and control technology than Parker. For further information call free on 00800 27 27 5374.



AEROSPACE

Key Markets

- Aircraft engines
- Business & general aviation
- Commercial transports
- Land-based weapons systems
- Military aircraft
- Missiles & launch vehicles
- Regional transports
- Unmanned aerial vehicles

Key Products

- Flight control systems & components
- Fluid conveyance systems
- Fluid metering delivery & atomization devices
- Fuel systems & components
- Hydraulic systems & components
- Inert nitrogen generating systems
- Pneumatic systems & components
- Wheels & brakes



HYDRAULICS

Key Markets

- Aerospace
- Aerial lift
- Agriculture
- Construction machinery
- Forestry
- Industrial machinery
- Mining
- Oil & gas
- Power generation & energy
- Truck hydraulics

Key Products

- Diagnostic equipment
- Hydraulic cylinders & accumulators
- Hydraulic motors & pumps
- Hydraulic systems
- Hydraulic valves & controls
- Power take-offs
- Rubber & thermoplastic hose & couplings
- Tube fittings & adapters
- Quick disconnects



CLIMATE CONTROL

Key Markets

- Agriculture
- Air conditioning
- Food, beverage & dairy
- Life sciences & medical
- Precision cooling
- Processing
- Transportation

Key Products

- CO² controls
- Electronic controllers
- Filter driers
- Hand shut-off valves
- Hose & fittings
- Pressure regulating valves
- Refrigerant distributors
- Safety relief valves
- Solenoid valves
- Thermostatic expansion valves



PNEUMATICS

Key Markets

- Aerospace
- Conveyor & material handling
- Factory automation
- Life science & medical
- Machine tools
- Packaging machinery
- Transportation & automotive

Key Products

- Air preparation
- Brass fittings & valves
- Manifolds
- Pneumatic accessories
- Pneumatic actuators & grippers
- Pneumatic valves & controls
- Quick disconnects
- Rotary actuators
- Rubber & thermoplastic hose & couplings
- Structural extrusions
- Thermoplastic tubing & fittings
- Vacuum generators, cups & sensors





PROCESS CONTROL

Key Markets

- Chemical & refining
- Food, beverage & dairy
- Medical & dental
- Microelectronics
- Oil & gas
- Power generation

Key Products

- Analytical sample conditioning products & systems
- Fluoropolymer chemical delivery fittings, valves & pumps
- High purity gas delivery fittings, valves & regulators
- Instrumentation fittings, valves & regulators
- Medium pressure fittings & valves
- Process control manifolds



ELECTROMECHANICAL

Key Markets

- Aerospace
- Factory automation
- Life science & medical
- Machine tools
- Packaging machinery
- Paper machinery
- Plastics machinery & converting
- Primary metals
- Semiconductor & electronics
- Textile
- Wire & cable

Key Products

- AC/DC drives & systems
- Electric actuators
- Controllers
- Gantry robots
- Gearheads
- Human machine interfaces
- Industrial PCs
- Inverters
- Linear motors, slides and stages
- Precision stages
- Stepper motors
- Servo motors, drives & controls
- Structural extrusions



FILTRATION

Key Markets

- Food & beverage
- Industrial machinery
- Life sciences
- Marine
- Mobile equipment
- Oil & gas
- Power generation
- Process
- Transportation

Key Products

- Analytical gas generators
- Compressed air & gas filters
- Condition monitoring
- Engine air, fuel & oil filtration & systems
- Hydraulic, lubrication & coolant filters
- Process, chemical, water & microfiltration filters
- Nitrogen, hydrogen & zero air generators



SEALING & SHIELDING

Key Markets

- Aerospace
- Chemical processing
- Consumer
- Energy, oil & gas
- Fluid power
- General industrial
- Information technology
- Life sciences
- Military
- Semiconductor
- Telecommunications
- Transportation

Key Products

- Dynamic seals
- Elastomeric o-rings
- EMI shielding
- Extruded & precision-cut, fabricated elastomeric seals
- Homogeneous & inserted elastomeric shapes
- High temperature metal seals
- Metal & plastic retained composite seals
- Thermal management



FLUID & GAS HANDLING

Key Markets

- Aerospace
- Agriculture
- Bulk chemical handling
- Construction machinery
- Food & beverage
- Fuel & gas delivery
- Industrial machinery
- Mobile
- Oil & gas
- Transportation
- Welding

Key Products

- Brass fittings & valves
- Diagnostic equipment
- Fluid conveyance systems
- Industrial hose
- PTFE & PFA hose, tubing & plastic fittings
- Rubber & thermoplastic hose & couplings
- Tube fittings & adapters
- Quick disconnects

ENGINEERING YOUR SUCCESS.

Parker Worldwide

AE – UAE, Dubai
Tel: +971 4 8127100
parker.me@parker.com

AR – Argentina, Buenos Aires
Tel: +54 3327 44 4129

AT – Austria, Wiener Neustadt
Tel: +43 (0)2622 23501-0
parker.austria@parker.com

AT – Eastern Europe, Wiener Neustadt
Tel: +43 (0)2622 23501 900
parker.easteurope@parker.com

AU – Australia, Castle Hill
Tel: +61 (0)2-9634 7777

AZ – Azerbaijan, Baku
Tel: +994 50 2233 458
parker.azerbaijan@parker.com

BE/LU – Belgium, Nivelles
Tel: +32 (0)67 280 900
parker.belgium@parker.com

BR – Brazil, Cachoeirinha RS
Tel: +55 51 3470 9144

BY – Belarus, Minsk
Tel: +375 17 209 9399
parker.belarus@parker.com

CA – Canada, Milton, Ontario
Tel: +1 905 693 3000

CH – Switzerland, Etoy
Tel: +41 (0) 21 821 02 30
parker.switzerland@parker.com

CN – China, Shanghai
Tel: +86 21 5031 2525

CZ – Czech Republic, Klecany
Tel: +420 284 083 111
parker.czechrepublic@parker.com

DE – Germany, Kaarst
Tel: +49 (0)2131 4016 0
parker.germany@parker.com

DK – Denmark, Ballerup
Tel: +45 43 56 04 00
parker.denmark@parker.com

ES – Spain, Madrid
Tel: +34 902 33 00 01
parker.spain@parker.com

FI – Finland, Vantaa
Tel: +358 (0)20 753 2500
parker.finland@parker.com

FR – France, Contamine s/Arve
Tel: +33 (0)4 50 25 80 25
parker.france@parker.com

GR – Greece, Athens
Tel: +30 210 933 6450
parker.greece@parker.com

HK – Hong Kong
Tel: +852 2428 8008

HU – Hungary, Budapest
Tel: +36 1 220 4155
parker.hungary@parker.com

IE – Ireland, Dublin
Tel: +353 (0)1 466 6370
parker.ireland@parker.com

IN – India, Mumbai
Tel: +91 22 6513 7081-85

IT – Italy, Corsico (MI)
Tel: +39 02 45 19 21
parker.italy@parker.com

JP – Japan, Tokyo
Tel: +(81) 3 6408 3901

KR – South Korea, Seoul
Tel: +82 2 559 0400

KZ – Kazakhstan, Almaty
Tel: +7 7272 505 800
parker.easteurope@parker.com

LV – Latvia, Riga
Tel: +371 6 745 2601
parker.latvia@parker.com

MX – Mexico, Apodaca
Tel: +52 81 8156 6000

MY – Malaysia, Shah Alam
Tel: +60 3 7849 0800

NL – The Netherlands, Oldenzaal
Tel: +31 (0)541 585 000
parker.nl@parker.com

NO – Norway, Ski
Tel: +47 64 91 10 00
parker.norway@parker.com

NZ – New Zealand, Mt Wellington
Tel: +64 9 574 1744

PL – Poland, Warsaw
Tel: +48 (0)22 573 24 00
parker.poland@parker.com

PT – Portugal, Leca da Palmeira
Tel: +351 22 999 7360
parker.portugal@parker.com

RO – Romania, Bucharest
Tel: +40 21 252 1382
parker.romania@parker.com

RU – Russia, Moscow
Tel: +7 495 645-2156
parker.russia@parker.com

SE – Sweden, Spånga
Tel: +46 (0)8 59 79 50 00
parker.sweden@parker.com

SG – Singapore
Tel: +65 6887 6300

SK – Slovakia, Banská Bystrica
Tel: +421 484 162 252
parker.slovakia@parker.com

SL – Slovenia, Novo Mesto
Tel: +386 7 337 6650
parker.slovenia@parker.com

TH – Thailand, Bangkok
Tel: +662 717 8140

TR – Turkey, Istanbul
Tel: +90 216 4997081
parker.turkey@parker.com

TW – Taiwan, Taipei
Tel: +886 2 2298 8987

UA – Ukraine, Kiev
Tel: +380 44 494 2731
parker.ukraine@parker.com

UK – United Kingdom, Warwick
Tel: +44 (0)1926 317 878
parker.uk@parker.com

US – USA, Cleveland
Tel: +1 216 896 3000

VE – Venezuela, Caracas
Tel: +58 212 238 5422

ZA – South Africa, Kempton Park
Tel: +27 (0)11 961 0700
parker.southafrica@parker.com

Ed. 2008-11-11

European Product Information Centre
Free phone: 00 800 27 27 5374
(from AT, BE, CH, CZ, DE, EE, ES, FI, FR, IE, IT, PT, SE, SK, UK)

Parker Hannifin Ltd.
Tachbrook Park Drive
Tachbrook Park, Warwick CV34 6TU
United Kingdom
Tel.: +44 (0) 1926 317 878
Fax: +44 (0) 1926 317 855
www.parker.com

